

SCD#QM5260

Upscreening/Manufacturing Specification FT02JMB-AD

Title Page
List of Effective Pages
Change List
Definitions
Acronyms and Abbreviations
Contents

1 Purpose/Intro
2 Reference Documents.....
3 Source of Parts
3.1 Original Part Manufacturer.....
3.2 Screening Company.....
3.3 UK Supplier
4 Manufacturing.....
4.1 Screening.....
5 Certificate of Conformity.....
5.1 Force Technologies Certificate of Conformity.....
6 Package Description.....
7 Traceability.....
8 Component selection
8.1 General.....
8.2 Nuclear Hardness
8.3 Baseline Component.....
8.4 Obsolescence notice.....

Date iss1. 18.10.02.....Changes:.....orig.....Init.....Name MLSalmon

Date iss.....Rev1-Changes:.....

Date iss.....Rev1-Changes:.....

Date iss.....Rev1-Changes:.....

Date iss.....Rev1-Changes:.....

Date iss.....Rev1-Changes:.....

1 **INTRODUCTION**

This document specifies the procurement details and screening requirements

In brief the part is: +5V Precision/Temperature Transducer packaged in TO-99 –55oC to +125oC screened to para.4.1

A package description is given in section 6 of this document.

2 **REFERENCE DOCUMENTS**

Test Method Standard
Microcircuits

MIL-STD-883
(latest issue)

Department of Defence
Washington
DC 20363-5100, USA

Sort, incoming and outgoing
Inspection procedures

3 **SOURCE OF PARTS**

This section provides an overview of the companies involved in the manufacture, screening and supply of the part. Original procurement of parts shall be from the address specified in section 3.3.

3.1 **Original Part Manufacturer**

The original part (Untested packaged/Die) are/were produced Analog Devices

Analog Device Corp
One Technology Way
Box 9106
Norwood, MA 02062-9106
USA

3.2 **Assy /Manu./Screening Company**

The above parts are then assembled and screened by:

Classified

Refer to section 4 for screening specifications.

3.3 **UK Supplier**

The assembled/screened parts shall be procured from:

Force Technologies Ltd
Ashley Court,
Henley,
Marlborough,
Wilts, UK
SN8 3RH

Tel: +44(0)1264 731200
Fax: +44(0)1264 731444

The Force Technologies part number(Ordering Code) is: **FT02JMB-AD**

4.0 **Manufacture**

Manufacturing processes as original manufacture.....Analog Devices
(Manufacturing processes, assembly, Screen and test equipment listings available for
inspection upon request.

4.1 SCREENING

The FT02JMB-AD shall be screened as specified in the table below.

All batches of parts shall be supplied with a Certificate of Conformity. The certificate of conformity shall reference the screening specified below.

Screening	Method	Req.t	Note
Internal visual	Sort, Incoming and Outgoing Inspection Procedures procedure: 05P-00212 10		N/A
Temperature cycling	1010, test condition C	100%	N/A
Constant acceleration	2001, test condition E (min) Y1 orientation only	100%	
Visual inspection		100%	N/A
Pre burn-in electrical parameters	In accordance with applicable device specification.	100%	N/A
Burn-in test	1015, 160 hours at 125°C minimum	100%	N/A
Interim (post burn-in) electrical parameters	In accordance with applicable device specification.	100%	N/A
Percentage defective allowable (PDA) calculation	5 percent	All lots	N/A
Seal a. Fine b. Gross	1014	100%	N/A
Final electrical test -55oC +25oC +125oC	In accordance with applicable device specification.	100%	4
External Visual	2009		N/A
Radiation latch-up	1020	Option	N/A

Notes:



+5V Precision Voltage Reference/Temperature Transducer

REF-02

FEATURES

- 5 Volt Output $\pm 0.3\%$ Max
- Temperature Voltage Output $2.1\text{mV}/^\circ\text{C}$
- Adjustment Range $\pm 3\%$ Min
- Excellent Temperature Stability $8.5\text{ppm}/^\circ\text{C}$ Max
- Low Noise $15\mu\text{V}_{\text{p-p}}$ Max
- Low Supply Current 1.4mA Max
- Wide Input Voltage Range 7V to 40V
- High Load-Driving Capability 20mA
- No External Components
- Short-Circuit Proof
- MIL-STD-883 Screening Available
- Available in Die Form

GENERAL DESCRIPTION

The REF-02 precision voltage reference provides a stable +5V output which can be adjusted over a $\pm 6\%$ range with minimal effect on temperature stability. Single-supply operation over an input voltage range of 7V to 40V, low current drain of 1mA, and excellent temperature stability are achieved with an improved bandgap design. Low cost, low noise, and low power make the REF-02 an excellent choice whenever a stable voltage reference is required. Applications include D/A and A/D converters, portable instrumentation, and digital voltmeters. The versatility of the REF-02 is enhanced by its use as a monolithic temperature transducer. For +10V references, see the REF-01 and REF-10 data sheets.

ORDERING INFORMATION[†]

$T_A = 25^\circ\text{C}$ $V_{OS \text{ MAX}}$ (mV)	PACKAGE				OPERATING TEMPERATURE RANGE
	TO-99	CERDIP 8-PIN	PLASTIC 8-PIN	LCC 20-CONTACT	
± 15	REF02AJ*	REF02AZ*	-	-	MIL
± 15	REF02EJ	REF02EZ	-	-	COM
± 25	REF02J*	REF02Z*	-	REF02RC/883	MIL
± 25	REF02HJ	REF02HZ	REF02HP	-	COM
± 50	REF02CJ	REF02CZ	-	-	COM
± 50	-	-	REF02CP	-	XIND
± 50	-	-	REF02CS††	-	XIND
± 100	REF02DJ	REF02DZ	REF02DP	-	COM

* For devices processed in total compliance to MIL-STD-883, add/883 after part number. Consult factory for 883 data sheet.

† Burn-in is available on commercial and industrial temperature range parts in CerDIP, plastic DIP, and TO-can packages.

†† For availability and burn-in information on SO and PLCC packages, contact your local sales office.

SIMPLIFIED SCHEMATIC

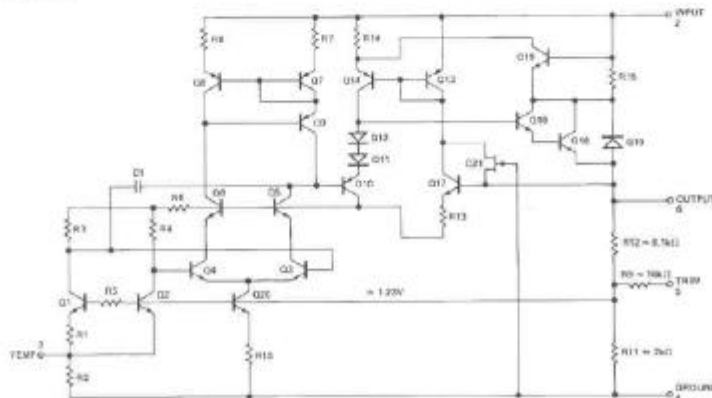

REV. B

Information furnished by Analog Devices is believed to be accurate and reliable. However, no responsibility is assumed by Analog Devices for its use, nor for any infringements of patents or other rights of third parties which may result from its use. No license is granted by implication or otherwise under any patent or patent rights of Analog Devices.

PIN CONNECTIONS

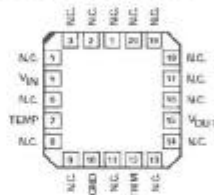

REF-02RC/883
LCC (RC-Suffix)

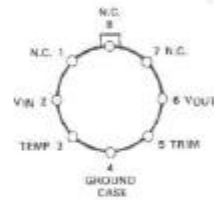

TO-99 (J-Suffix)

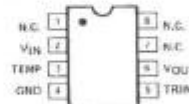

8-PIN HERMETIC DIP
(Z-Suffix)
EPOXY MINI-DIP
(P-Suffix)
8-PIN SO
(S-Suffix)

One Technology Way, P.O. Box 9106, Norwood, MA 02062-9106, U.S.A.
Tel: 617/329-4700 Fax: 617/326-8703 Twx: 710/394-6577
Telex: 924491 Cable: ANALOG NORWOODMASS

REF-02

ABSOLUTE MAXIMUM RATINGS (Note 1)

Input Voltage	
REF-02A, E, H, RC, All DICE	40V
REF-02C, D	30V
Output Short-Circuit Duration (to Ground or V_{IN})	Indefinite
Storage Temperature Range	
J, RC, and Z Packages	-65°C to +150°C
P Packages	-65°C to +125°C
Operating Temperature Range	
REF-02A, REF-02, REF-02RC	-55°C to +125°C
REF-02E, REF-02H	0°C to +70°C
REF-02CJ, CZ, REF-02D	0°C to +70°C
REF-02CP, CS	-40°C to +85°C
Lead Temperature (Soldering, 60 sec)	300°C

Junction Temperature (T_J) -65°C to +150°C

PACKAGE TYPE	θ_{JA} (NOTE 2)	θ_{JC}	UNITS
TO-99 (J)	170	24	°C/W
8-Pin Hermetic DIP (Z)	162	26	°C/W
8-Pin Plastic DIP (P)	110	50	°C/W
20-Contact LCC (RC, TC)	120	40	°C/W
8-Pin SO (S)	160	44	°C/W
20-Contact PLCC (PC)	80	39	°C/W

NOTES:

1. Absolute maximum ratings apply to both DICE and packaged parts, unless otherwise noted.
2. θ_{JA} is specified for worst case mounting conditions, i.e., θ_{JA} is specified for device in socket for TO, CerDIP, P-DIP, and LCC packages; θ_{JA} is specified for device soldered to printed circuit board for SO and PLCC packages.

ELECTRICAL CHARACTERISTICS at $V_{IN} = +15V$, $T_A = +25^\circ C$, unless otherwise noted.

PARAMETER	SYMBOL	CONDITIONS	REF-02A/E			REF-02/H			UNITS
			MIN	TYP	MAX	MIN	TYP	MAX	
Output Voltage	V_O	$I_L = 0$	4.985	5.000	5.015	4.975	5.000	5.025	V
Output Adjustment Range	ΔV_{trim}	$R_p = 10k\Omega$	± 3	± 6	—	± 3	± 6	—	%
Output Voltage Noise	e_{np-p}	0.1Hz to 10Hz (Note 7)	—	10	15	—	10	15	μV_{p-p}
Line Regulation (Note 2)		$V_{IN} = 8V$ to 33V	—	0.006	0.010	—	0.006	0.010	%/V
Load Regulation (Note 2)		$I_L = 0$ to 10mA	—	0.005	0.010	—	0.006	0.010	%/mA
Turn-on Settling Time	t_{ON}	To $\pm 0.1\%$ of final value	—	5	—	—	5	—	μs
Quiescent Supply Current	I_{sV}	No Load	—	1.0	1.4	—	1.0	1.4	mA
Load Current	I_L		10	21	—	10	21	—	mA
Sink Current	I_S	(Note 8)	-0.3	-0.5	—	-0.3	-0.5	—	mA
Short-Circuit Current	I_{sc}	$V_O = 0$	—	30	—	—	30	—	mA
Temperature Voltage Output	V_T	(Note 3)	—	630	—	—	630	—	mV

ELECTRICAL CHARACTERISTICS at $V_{IN} = +15V$, $-55^\circ C \leq T_A \leq \pm 125^\circ C$ for REF-02A and REF-02, $0^\circ C \leq T_A \leq +70^\circ C$ for REF-02E and REF-02H, $I_L = 0mA$, unless otherwise noted.

PARAMETER	SYMBOL	CONDITIONS	REF-02A/E			REF-02/H			UNITS
			MIN	TYP	MAX	MIN	TYP	MAX	
Output Voltage Change with Temperature (Notes 4, 5)	ΔV_{OT}	$0^\circ C \leq T_A \leq +70^\circ C$ $-55^\circ C \leq T_A \leq +125^\circ C$	—	0.02	0.06	—	0.07	0.17	%
Output Voltage Temperature Coefficient	TCV_O	(Note 6)	—	3	8.5	—	10	25	ppm/°C
Change in V_O Temperature Coefficient with Output Adjustment		$R_p = 10k\Omega$	—	0.7	—	—	0.7	—	ppm/%
Line Regulation ($V_{IN} = 8$ to 33V) (Note 2)		$0^\circ C \leq T_A \leq +70^\circ C$ $-55^\circ C \leq T_A \leq +125^\circ C$	—	0.007	0.012	—	0.007	0.012	%/V
Load Regulation ($I_L = 0$ to 8mA) (Note 2)		$0^\circ C \leq T_A \leq +70^\circ C$ $-55^\circ C \leq T_A \leq +125^\circ C$	—	0.006	0.010	—	0.007	0.012	%/mA
Temperature Voltage Output Temperature Coefficient	TCV_T	(Note 3)	—	2.1	—	—	2.1	—	mV/°C

NOTES:

1. Guaranteed by design.
2. Line and Load Regulation specifications include the effect of self heating.
3. Limit current in or out of pin 3 to 50mA and capacitance on pin 3 to 30pF.
4. ΔV_{OT} is defined as the absolute difference between the maximum output voltage and the minimum output voltage over the specified temperature range expressed as a percentage of 5V.

$$\Delta V_{OT} = \frac{V_{MAX} - V_{MIN}}{5V} \times 100$$

5. ΔV_{OT} specification applies trimmed to $\pm 5.000V$ or untrimmed.
6. TCV_O is defined as ΔV_{OT} divided by the temperature range, i.e.,

$$TCV_O = \frac{\Delta V_{OT}}{70^\circ C}$$

7. Sample Tested.
8. During sink current test the driver meets the output voltage specified.

ELECTRICAL CHARACTERISTICS at $V_{IN} = +15V$, $T_A = 25^\circ C$, unless otherwise noted.

PARAMETER	SYMBOL	CONDITIONS	REF-02C			REF-02D			UNITS
			MIN	TYP	MAX	MIN	TYP	MAX	
Output Voltage	V_O	$I_L = 0mA$	4.950	5.000	5.050	4.900	5.000	5.100	V
Output Adjustment Range	ΔV_{trim}	$R_P = 10k\Omega$	± 2.7	± 6.0	—	± 2.0	± 6.0	—	%
Output Voltage Noise	e_{NP-P}	0.1Hz to 10Hz (Note 7)	—	12	18	—	12	—	μV_{P-P}
Line Regulation (Note 2)		$V_{IN} = 6V$ to $30V$	—	0.009	0.015	—	0.010	0.04	%/V
Load Regulation (Note 2)		$I_L = 0$ to $8mA$ $I_L = 0$ to $4mA$	—	0.008	0.015	—	—	—	%/mA
Turn-on Settling Time	t_{ON}	To $\pm 0.1\%$ of final value	—	5	—	—	5	—	μs
Quiescent Supply Current	I_{SQ}	No Load	—	1.0	1.6	—	1.0	2.0	mA
Load Current	I_L		8	21	—	8	21	—	mA
Sink Current	I_S	(Note 8)	-0.3	-0.5	—	-0.3	-0.5	—	mA
Short-Circuit Current	I_{SC}	$V_O = 0$	—	30	—	—	30	—	mA
Temperature Voltage Output	V_T	(Note 3)	—	630	—	—	630	—	mV

ELECTRICAL CHARACTERISTICS at $V_{IN} = +15V$; $I_L = 0mA$, $0^\circ C \leq T_A \leq +70^\circ C$ for REF-02CJ, CZ, DJ, DZ, DP; $-40^\circ C \leq T_A \leq +85^\circ C$ for REF-02CP, CS; unless otherwise noted.

PARAMETER	SYMBOL	CONDITIONS	REF-02C			REF-02D			UNITS
			MIN	TYP	MAX	MIN	TYP	MAX	
Output Voltage Change with Temperature	ΔV_{OT}	(Notes 4 and 5)	—	0.14	0.45	—	0.49	1.7	%
Output Voltage Temperature Coefficient	TCV_O	(Note 5)	—	20	65	—	70	250	ppm/ $^\circ C$
Change in V_O Temperature Coefficient With Output Adjustment		$R_P = 10k\Omega$	—	0.7	—	—	0.7	—	ppm/%
Line Regulation (Note 2)		$V_{IN} = 6V$ to $30V$	—	0.011	0.018	—	0.012	0.05	%/V
Load Regulation (Note 2)		$I_L = 0$ to $5mA$	—	0.008	0.018	—	0.016	0.05	%/mA
Temperature Voltage Output Temperature Coefficient	TCV_T	(Note 3)	—	2.1	—	—	2.1	—	mV/ $^\circ C$

NOTES:

1. Guaranteed by design.
2. Line and Load Regulation specifications include the effect of self heating.
3. Limit current in or out of pin 3 to 50mA and capacitance on pin 3 to 30pF.
4. ΔV_{OT} is defined as the absolute difference between the maximum output voltage and the minimum output voltage over the specified temperature range expressed as a percentage of 5V.

$$\Delta V_{OT} = \left| \frac{V_{MAX} - V_{MIN}}{5V} \right| \times 100$$

5. ΔV_{OT} specification applies trimmed to $\pm 5.000V$ or untrimmed.
6. TCV_O is defined as ΔV_{OT} divided by the temperature range, i.e.,

$$TCV_O = \frac{\Delta V_{OT}}{70^\circ C}$$

7. Sample Tested.
8. During sink current test the device meets the output voltage specified.

REF-02

DICE CHARACTERISTICS (125° C TESTED DICE AVAILABLE)

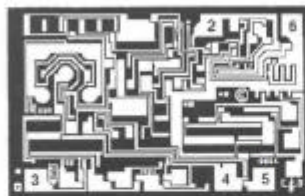

DIE SIZE 0.074 × 0.048 inch, 3552 sq. mils
(1.88 × 1.22 mm, 2.29 sq. mm)

2. INPUT VOLTAGE (V_{IN})
3. TEMPERATURE TRANSDUCER
OUTPUT VOLTAGE (TEMP)
4. GROUND
5. TRIM
6. OUTPUT VOLTAGE (V_{OUT})

WAFER TEST LIMITS at $V_{IN} = +15V$, $T_A = 25^\circ C$ for REF-02N and REF-02G devices; $T_A = 125^\circ C$ for REF-02NT and REF-02GT devices, unless otherwise noted. (Note 3)

PARAMETER	SYMBOL	CONDITIONS	REF-02NT LIMIT	REF-02N LIMIT	REF-02GT LIMIT	REF-02G LIMIT	UNITS
Output Voltage	V_O	$I_L = 0$	4.975	4.985	4.950	4.975	V MIN
			5.025	5.015	5.050	5.025	V MAX
Output Adjustment Range	V_{trim}	$R_p = 10k\Omega$	—	±3	—	±3	% MIN
Line Regulation		$V_{IN} = 8V$ to $33V$	0.015	0.01	0.015	0.01	%/V MAX

NOTE:

Electrical tests are performed at wafer probe to the limits shown. Due to variations in assembly methods and normal yield loss, yield after packaging is not guaranteed for standard product dice. Consult factory to negotiate specifications based on dice lot qualification through sample lot assembly and testing.

TYPICAL ELECTRICAL CHARACTERISTICS at $V_{IN} = +15V$, $T_A = +25^\circ C$, unless otherwise noted.

PARAMETER	SYMBOL	CONDITIONS	REF-02NT TYPICAL	REF-02N TYPICAL	REF-02GT TYPICAL	REF-02G TYPICAL	UNITS
Temp. Voltage Output	V_T	(Notes 1, 2)	630	630	630	630	mV
Temp. Voltage Output Temp. Coefficient	TCV_T	(Notes 1, 2)	2.1	2.1	2.1	2.1	mV/°C
Output Voltage Temp. Coefficient	TCV_O		10	10	10	10	ppm/°C
Load Regulation		$I_L = 0$ to $10mA$ $I_L = 0$ to $8mA$, NT, GT @ $+125^\circ C$	0.007	0.006	0.009	0.006	%/mA
Output Voltage Noise	e_{np-p}	0.1Hz to 10Hz	10	10	10	10	μV_{p-p}
Turn-On Settling Time	t_{ON}	To ±0.1% of final value, NT, GT @ $+125^\circ C$	7.5	5.0	7.5	5.0	μs
Quiescent Supply Current	I_{SQ}	No Load, NT, GT @ $+125^\circ C$	1.4	1.0	1.4	1.0	mA
Load Current	I_L		21	21	21	21	mA
Sink Current	I_S		-0.5	-0.5	-0.5	-0.5	mA
Short-Circuit Current	I_{SC}	$V_O = 0$	30	30	30	30	mA

NOTES:

1. See AN-18 for detailed REF-02 thermometer applications information.
2. Limit current in or out of pin 3 to 50mA and capacitance on pin 3 to 30pF.
3. For $+25^\circ C$ specifications of REF-02NT and REF-02GT, see REF-02N and REF-02G respectively.

REF-02

OUTPUT ADJUSTMENT

The REF-02 trim terminal can be used to adjust the output voltage over a $5V \pm 300mV$ range. This feature allows the system designer to trim system errors by setting the reference to a voltage other than 5V. Of course, the output can also be set to exactly 5.000V or to 5.12V for binary applications.

Adjustment of the output does not significantly affect the temperature performance of the device. Typically, the temperature coefficient change is $0.7ppm/^{\circ}C$ for 100mV of output adjustment.

OUTPUT ADJUSTMENT CIRCUIT

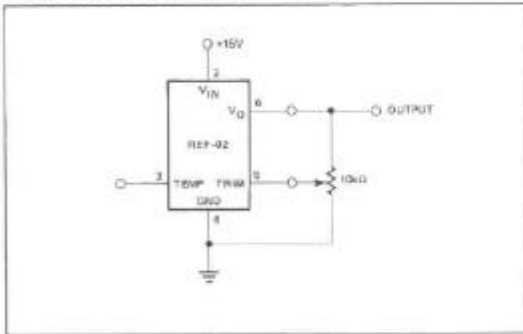

BURN-IN CIRCUIT

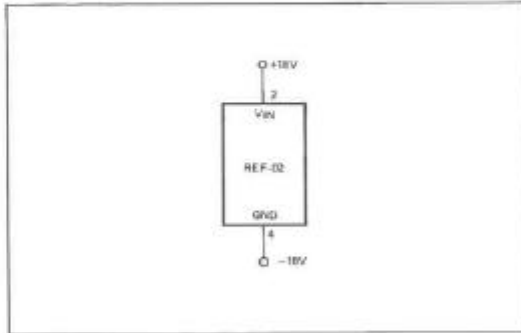

TYPICAL PERFORMANCE CHARACTERISTICS

OUTPUT WIDEBAND NOISE vs BANDWIDTH (0.1Hz TO FREQUENCY INDICATED)

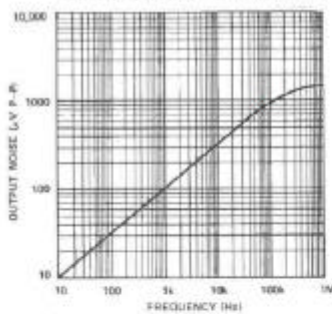

LINE REGULATION vs FREQUENCY

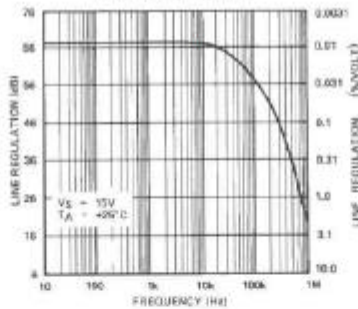

OUTPUT CHANGE DUE TO THERMAL SHOCK

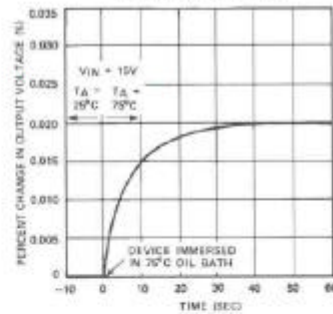

REF-02

TYPICAL PERFORMANCE CHARACTERISTICS

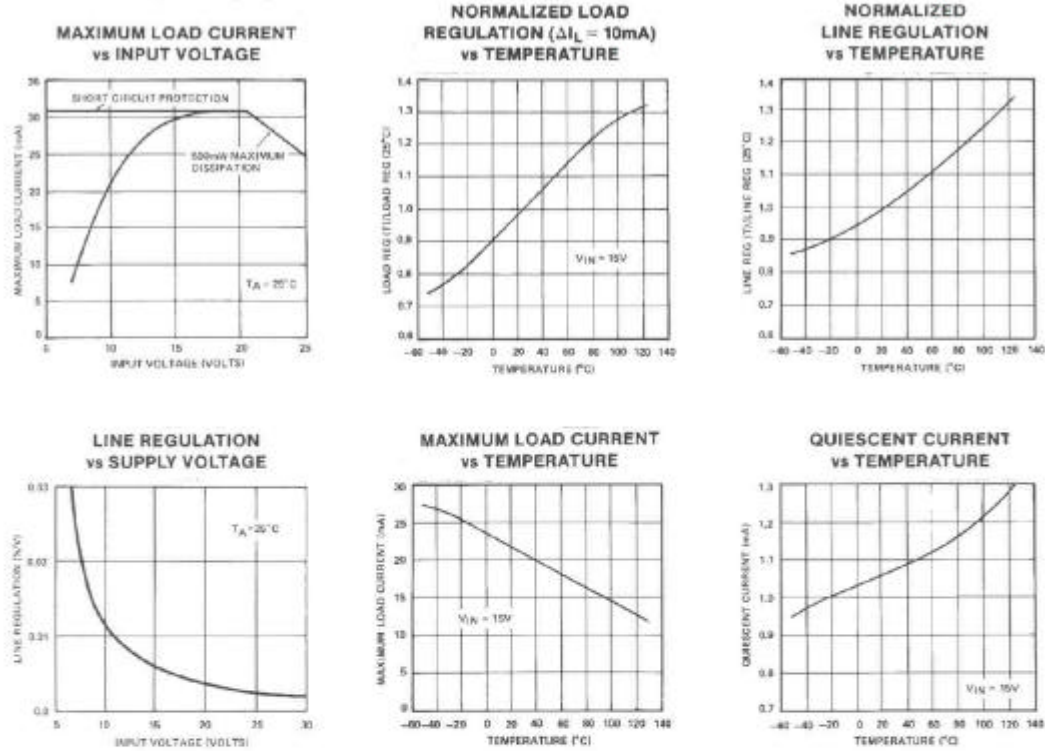

TYPICAL APPLICATIONS

$\pm 5\text{V}$ REFERENCE

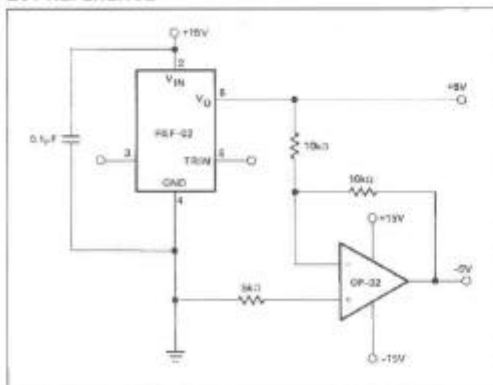

$\pm 2.5\text{V}$ REFERENCE

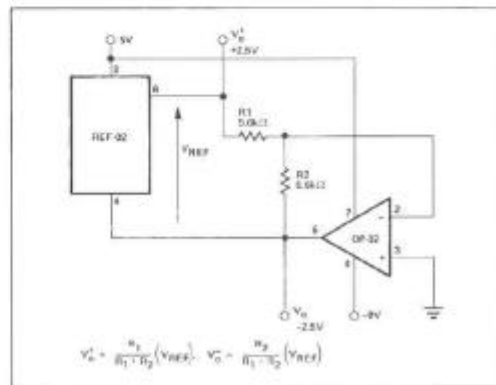

REF-02

PRECISION TEMPERATURE TRANSDUCER WITH REMOTE SENSOR

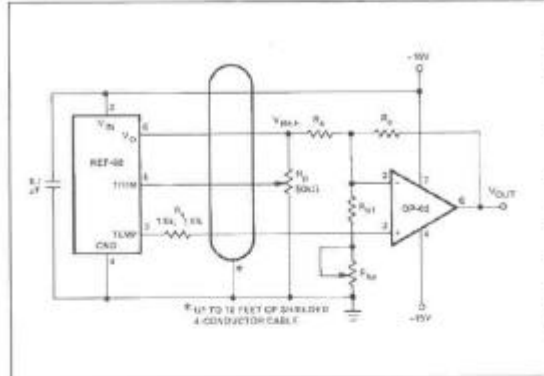

RESISTOR VALUES

TCV _{OUT} SLOPE (S)	10mV/°C	100mV/°C	10mV/°F
TEMPERATURE RANGE	-55° C to +125° C	-55° C to +125° C	-67° F to +257° C
OUTPUT VOLTAGE RANGE	-0.55V to +1.25V	-5.5V to +12.5V*	-0.67V to +2.57V
ZERO-SCALE	0V @ 0° C	0V @ 0° C	0V @ 0° F
R _a (± 1% resistor)	9.09kΩ	15kΩ	7.5kΩ
R _{b1} (± 1% resistor)	1.5kΩ	1.02kΩ	1.21kΩ
R _{bp} (Potentiometer)	200Ω	500Ω	200Ω
R _c (± 1% resistor)	5.11kΩ	84.5kΩ	8.25kΩ

*For 125° C operation, the op amp output must be able to swing to +12.5V, increase V_{IN} to +18V from +15V if this is a problem.

TYPICAL TEMPERATURE VOLTAGE OUTPUT vs TEMPERATURE (REF-02A)

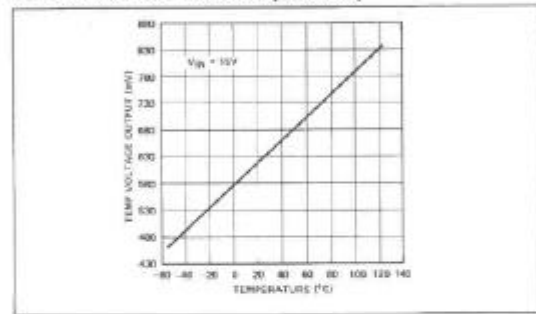

REFERENCE STACK WITH EXCELLENT LINE REGULATION

Two REF-01's and one REF-02 can be stacked to yield 5.000V, 15.000V and 25.000V outputs. An additional advantage of this circuit is near-perfect line regulation of the 5.0V and 15.0V outputs. A 27V to 55V input change produces an output change which is less than the noise voltage of the devices. A load bypass resistor (R_B) provides a path for the supply current (I_{SY}) of the 15.000V regulator.

In general, any number of REF-01's and REF-02's can be stacked this way. For example, ten devices will yield ten outputs in 5V or 10V steps. The line voltage can range from 100V to 130V. However, care must be taken to ensure that the total load currents do not exceed the maximum usable current (typically 21mA).

TEMPERATURE CONTROLLER

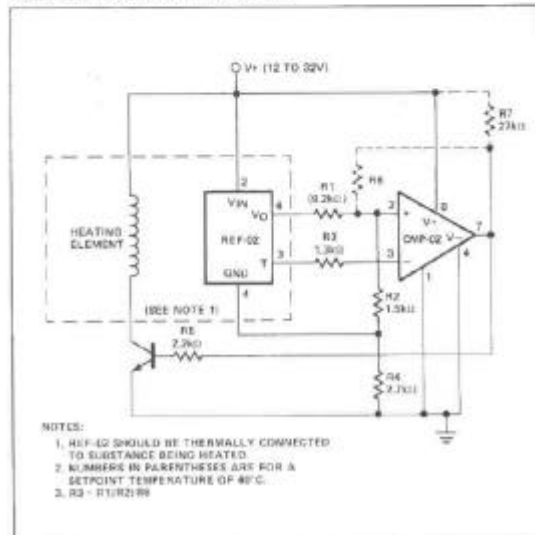

NOTES:

1. REF-02 SHOULD BE THERMALLY CONNECTED TO SUBSTANCE BEING HEATED.
2. NUMBERS IN PARENTHESES ARE FOR A SETPOINT TEMPERATURE OF 80° C.
3. R3 = R1/R2/R8

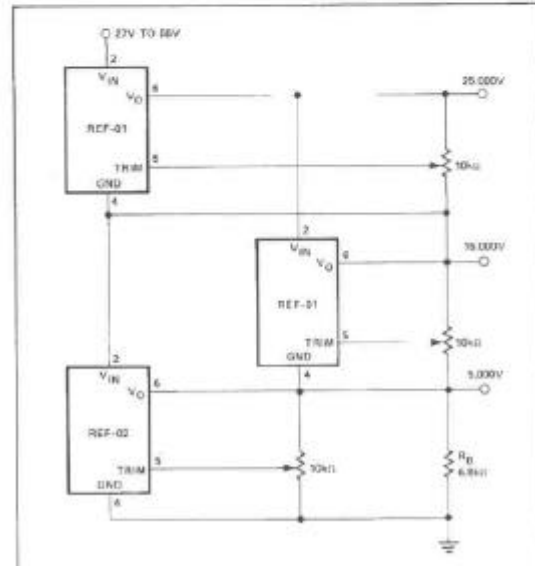

REF-02

PRECISION CURRENT SOURCE

A current source with 35V output compliance and excellent output impedance can be obtained using this circuit. REF-02 (2) keeps the line voltage and power dissipation constant in device (1); the only important error consideration at room temperature is the negative supply rejection of the op amp. The typical $3\mu\text{V}/\text{V}$ PSRR of the OP-02E will create a 20ppm change ($3\mu\text{V}/\text{V} \times 35\text{V}/5\text{V}$) in output current over a 35V range. For example, a 5mA current source can be built ($R = 1\text{k}\Omega$) with $350\text{M}\Omega$ output impedance.

$$R_0 = \frac{35\text{V}}{20 \times 10^{-6} \times 5\text{mA}}$$

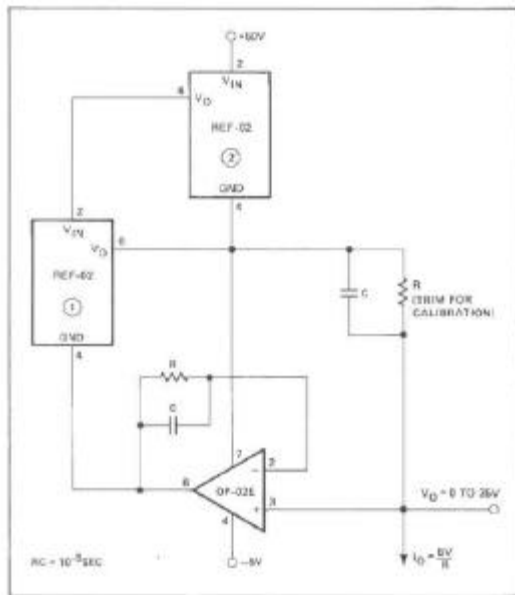

CURRENT SOURCE

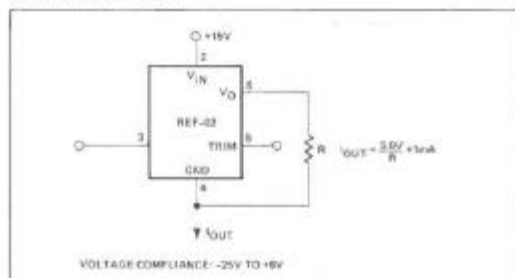

CURRENT SINK

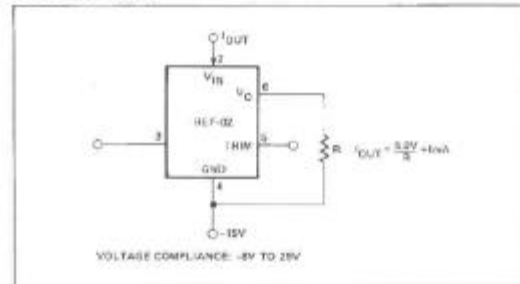

D/A CONVERTER REFERENCE

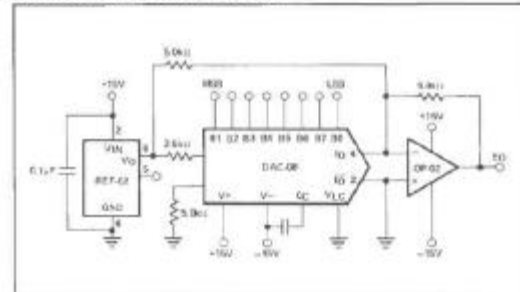

±3V REFERENCE

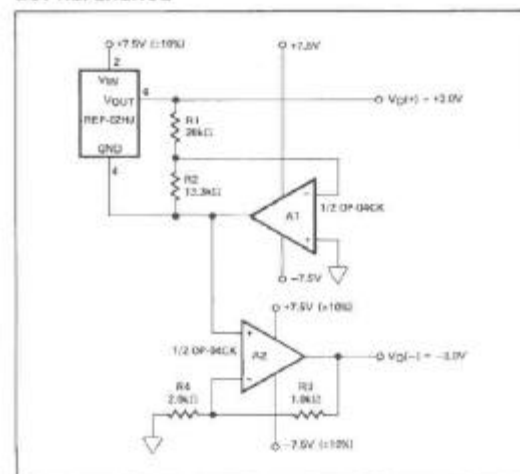

SUPPLY BYPASSING

For best results, it is recommended that the power supply pin is bypassed with a $0.1\mu\text{F}$ disc ceramic capacitor.

5 CERTIFICATE OF CONFORMITY

All batches of parts shall be supplied with certificates of conformity. The certificate of conformity shall reference the test certificate.

5.1 Force Technologies Certificate of Conformity

Screening specified in section 4 of this document.
Force Technologies part number.

6 PACKAGE DESCRIPTION

TO-99 8 pin

7 TRACEABILITY (IF APPLICABLE)

Traceability shall be provided by the date code printed on the top/bottom side of each device. ISO9002 traceability procedures to apply using batch codes

COMPONENT SELECTION

8.1 General

No component or component supplier shall be changed without the express written consent of the customer, following the submission of evidence to justify that the replacement component will meet all required parameters, including radiation immunity.

8.2 Nuclear Hardness (Not applicable)

8.3 The baseline component:

Original Manufacturer:	Analog Devices
Part number:	REF-02J

The vendor shall determine that the die size, mask and if possible the manufacturing process has not changed since the manufacture of the baseline component. This shall be done prior to acceptance of any order by the vendor. If such a change has occurred, written notification shall be given to the customer the changes and possible alternatives. The vendor shall take no further action until a way forward has been agreed with the customer.

8.4 Obsolescence

Upon acceptance of an order the vendor becomes responsible for all component obsolescence until completion of that order. The vendor will inform customer of any PCN.

FORCE
TECHNOLOGIES LTD

Ashley Crt, Henley,
Marlborough, Wilts, SN8 3RH

Tel: +44(0)1264 731200

Fax:+44(0)1264 731444

E-mail

info@forcetechnologies.co.uk

tech@forcetechnologies.co.uk

sales@forcetechnologies.co.uk

www.forcetechnologies.co.uk