

74AC/ACT11472

9-Wide Transceiver with Dual Enable; 3-State

Objective Specification

ACL Products

FEATURES

- 3-State buffers
- Output capability: ± 24 mA
- CMOS (AC) and TTL (ACT) voltage level inputs
- 50 Ω incident wave switching
- Center-pin V_{CC} and ground configuration to minimize high-speed switching noise
- I_{CC} category: MSI

DESCRIPTION

The 74AC/ACT11472 high-performance CMOS devices combine very high speed and high output drive comparable to the most advanced TTL families.

The 74AC/ACT11472 device contains two sets of latches for temporary storage of data flowing in either direction. Dual Latch Enable (\overline{LE}_{AB} , \overline{LE}_{BA}) and Output Enable (\overline{OE}_{AB} , \overline{OE}_{BA}) inputs are provided for each set of latches to permit independent control of inputting and outputting in either direction of data flow.

GENERAL INFORMATION

SYMBOL	PARAMETER	CONDITIONS $T_A = 25^\circ\text{C}; \text{GND} = 0\text{V};$ $V_{CC} = 5.0\text{V}$	TYPICAL		UNIT
			AC	ACT	
t_{PLH}/t_{PHL}	Propagation delay \overline{LE}_{XX} to A_n or B_n	$C_L = 50\text{pF}$	5.2	6.7	ns
C_{PD}	Power dissipation capacitance per register ¹	$f = 1\text{MHz};$ $C_L = 50\text{pF}$	Enabled: 200 Disabled: 50	200 50	pF
C_{IN}	Input capacitance	$V_I = 0\text{V}$ or V_{CC}	4.5	4.5	pF
C_{VO}	I/O capacitance	$V_{VO} = 0\text{V}$ or V_{CC} ; Disabled	12	12	pF
I_{LATCH}	Latch-up current	Per Jeduc Jc40.2 Standard 17	500	500	mA

Note:

1. C_{PD} is used to determine the dynamic power dissipation (P_D in μW):

$$P_D = C_{PD} \times V_{CC}^2 \times f_I + \sum (C_L \times V_{CC}^2 \times f_O) \text{ where:}$$

f_I = input frequency in MHz, C_L = output load capacitance in pF,

f_O = output frequency in MHz, V_{CC} = supply voltage in V,

$\sum (C_L \times V_{CC}^2 \times f_O)$ = sum of outputs

ORDERING INFORMATION

PACKAGES	TEMPERATURE RANGE	ORDER CODE
28-pin plastic DIP (300mil-wide)	-40°C to +85°C	74AC11472N 74ACT11472N
28-pin plastic SO (300mil-wide)	-40°C to +85°C	74AC11472D 74ACT11472D

PIN CONFIGURATION

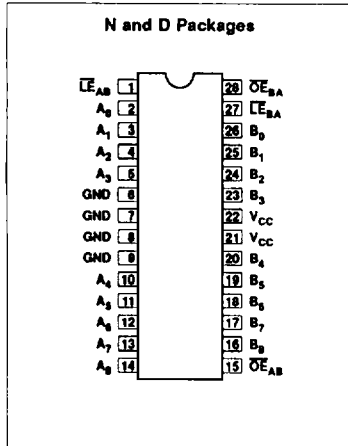

LOGIC SYMBOL

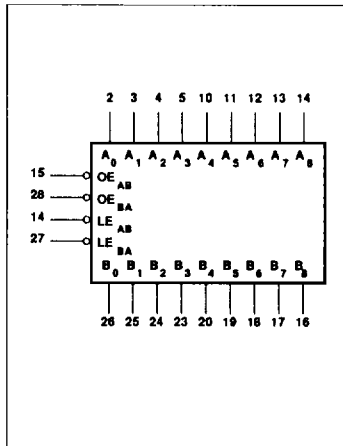

LOGIC SYMBOL (IEEE/IEC)

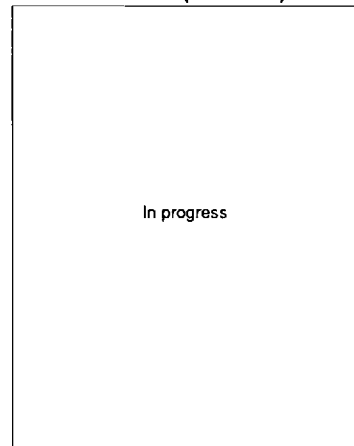

9-Wide Transceiver with Dual Enable; 3-State

74AC/ACT11472

PIN DESCRIPTION

PIN NUMBER	SYMBOL	NAME AND FUNCTION
1	\overline{LE}_{AB}	A-to-B latch enable (active Low)
27	\overline{LE}_{BA}	B-to-A latch enable (active Low)
15	\overline{OE}_{AB}	A-to-B output enable input (active Low)
28	\overline{OE}_{BA}	B-to-A output enable input (active Low)
2, 3, 4, 5, 10, 11, 12, 13, 14	$A_0 - A_8$	Data inputs/outputs (A side)
26, 25, 24, 23, 20, 19, 18, 17, 16	$B_0 - B_8$	Data inputs/outputs (B side)
6, 7, 8, 9	GND	Ground (0V)
21, 22	V_{CC}	Positive supply voltage

FUNCTION TABLE

INPUTS			OUTPUTS	STATUS
\overline{OE}_{xx}	\overline{LE}_{xx}	Data		
H	X	X	Z	Latch register and disable outputs
L	L	l h	L H	Enable and read register
L	H	X X	L H	Latch and read register

H = High voltage level

h = High state present one setup time before the Low-to-High transition

L = Low voltage level

l = Low state present one setup time before the Low-to-High transition

X = Don't care

Z = High-impedance state

9-Wide Transceiver with Dual Enable; 3-State

74AC/ACT11472

RECOMMENDED OPERATING CONDITIONS

SYMBOL	PARAMETER	74AC11472			74ACT11472			UNIT
		Min	Nom	Max	Min	Nom	Max	
V_{CC}	DC supply voltage	3.0 ¹	5.0	5.5	4.5	5.0	5.5	V
V_I	Input voltage	0		V_{CC}	0		V_{CC}	V
V_O	Output voltage	0		V_{CC}	0		V_{CC}	V
$\Delta t/\Delta v$	Input transition rise or fall rate	0		10	0		10	ns/V
T_A	Operating free-air temperature	-40		+85	-40		+85	°C

NOTE:

- No electrical or switching characteristics are specified at $V_{CC} < 3V$. Operation between 2V and 3V is not recommended, but within that range, a device output will maintain a previously established logic state.

ABSOLUTE MAXIMUM RATINGS¹

SYMBOL	PARAMETER	TEST CONDITIONS	RATING	UNIT
V_{CC}	DC supply voltage		-0.5 to +7.0	V
I_{IK} or V_I	DC input diode current ²	$V_I < 0$	-20	mA
		$V_I > V_{CC}$	20	
	DC input voltage		-0.5 to $V_{CC} + 0.5$	V
I_{OK} or V_O	DC output diode current ²	$V_O < 0$	-50	mA
		$V_O > V_{CC}$	50	
	DC output voltage		-0.5 to $V_{CC} + 0.5$	V
I_O	DC output source or sink current per output pin	$V_O = 0$ to V_{CC}	±50	mA
I_{CC} or I_{GND}	DC V_{CC} current		±225	mA
	DC ground current		±225	
T_{STG}	Storage temperature		-65 to 150	°C
P_{TOT}	Power dissipation per package Plastic DIP	Above 70°C: derate linearly by 8mW/K	500	mW
	Power dissipation per package Plastic surface mount (SO)	Above 70°C: derate linearly by 6mW/K	400	mW

NOTES:

- Stresses beyond those listed may cause permanent damage to the device. These are stress ratings only and functional operation of the device at these or any other conditions beyond those indicated under "recommended operating conditions" is not implied. Exposure to absolute-maximum-rated conditions for extended periods may affect device reliability.
- The input and output voltage ratings may be exceeded if the input and output current ratings are observed.

9-Wide Transceiver with Dual Enable; 3-State

74AC/ACT11472

DC ELECTRICAL CHARACTERISTICS

SYMBOL	PARAMETER	TEST CONDITIONS	V _{CC}	74AC11472				74ACT11472				UNIT		
				T _A = +25°C		T _A = -40°C to +85°C		T _A = +25°C		T _A = -40°C to +85°C				
				V	Min	Max	Min	Max	Min	Max	Min		Max	
V _{IH}	High-level input voltage		3.0	2.10		2.10						V		
			4.5	3.15		3.15		2.0		2.0				
			5.5	3.85		3.85		2.0		2.0				
V _{IL}	Low-level input voltage		3.0		0.90		0.90					V		
			4.5		1.35		1.35		0.8		0.8			
			5.5		1.65		1.65		0.8		0.8			
V _{OH}	High-level output voltage	V _I = V _{IL} or V _{IH}	I _{OH} = -50μA	3.0	2.9		2.9					V		
				4.5	4.4		4.4		4.4		4.4			
				5.5	5.4		5.4		5.4		5.4			
				I _{OH} = -4mA	3.0	2.58		2.48						
					4.5	3.94		3.8		3.94			3.8	
					5.5	4.94		4.8		4.94			4.8	
I _{OH} = -75mA ¹	3.0			3.85				3.85						
	5.5													
V _{OL}	Low-level output voltage	V _I = V _{IL} or V _{IH}	I _{OL} = 50μA	3.0		0.1		0.1				V		
				4.5		0.1		0.1		0.1			0.1	
				5.5		0.1		0.1		0.1			0.1	
				I _{OL} = 12mA	3.0		0.36		0.44					
					4.5		0.36		0.44		0.36			0.44
					5.5		0.36		0.44		0.36			0.44
I _{OL} = 75mA ¹	3.0				1.65				1.65					
	5.5													
I _I	Input leakage current	V _I = V _{CC} or GND	5.5		±0.1		±1.0		±0.1		±1.0	μA		
I _{OZ}	3-State output off-state current	V _I = V _{IL} or V _{IH} , V _O = V _{CC} or GND	5.5		±0.5		±5.0		±0.5		±5.0	μA		
I _{CC}	Quiescent supply current	V _I = V _{CC} or GND, I _O = 0	5.5		8.0		80		8.0		80	μA		
ΔI _{CC}	Supply current, TTL inputs High ²	One input at 3.4V, other inputs at V _{CC} or GND	5.5						0.9		1.0	mA		

NOTES:

- Not more than one output should be tested at a time, and the duration of the test should not exceed 10ms.
- This is the increase in supply current for each input that is at one of the specified TTL voltage levels rather than 0V or V_{CC}.