

## DM74S138, DM74S139 Decoders/Demultiplexers

### General Description

These Schottky-clamped circuits are designed to be used in high-performance memory-decoding or data-routing applications, requiring very short propagation delay times. In high-performance memory systems these decoders can be used to minimize the effects of system decoding. When used with high-speed memories, the delay times of these decoders are usually less than the typical access time of the memory. This means that the effective system delay introduced by the decoder is negligible.

The S138 decodes one-of-eight lines, based upon the conditions at the three binary select inputs and the three enable inputs. Two active-low and one active-high enable inputs reduce the need for external gates or inverters when expanding. A 24-line decoder can be implemented with no external inverters, and a 32-line decoder requires only one inverter. An enable input can be used as a data input for demultiplexing applications.

The S139 comprises two separate two-line-to-four-line decoders in a single package. The active-low enable input can be used as a data line in demultiplexing applications.

All of these decoders/demultiplexers feature fully buffered inputs, presenting only one normalized load to its driving circuit. All inputs are clamped with high-performance Schottky diodes to suppress line-ringing and simplify system design.

### Features

- Designed specifically for high speed:
  - Memory decoders
  - Data transmission systems
- S138 3-to-8-line decoders incorporates 3 enable inputs to simplify cascading and/or data reception
- S139 contains two fully independent 2-to-4-line decoders/demultiplexers
- Schottky clamped for high performance
- Typical propagation delay time (3 levels of logic)
  - S138 8 ns
  - S139 7.5 ns
- Typical power dissipation
  - S138 245 mW
  - S139 300 mW

### Connection Diagrams

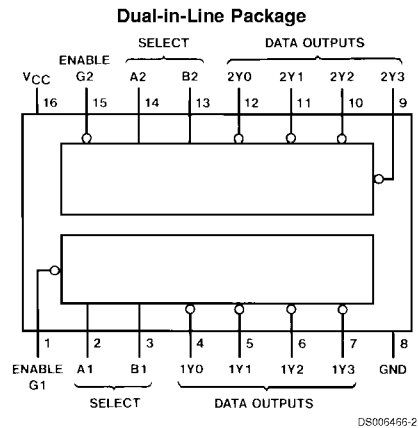
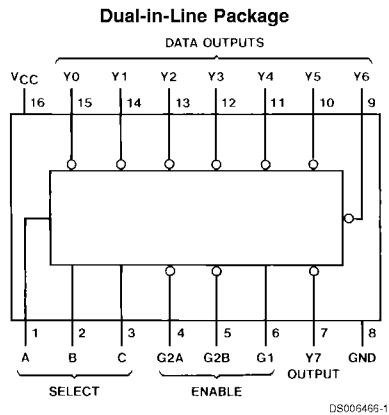

**Order Number DM54S138J, DM54S139J, DM54S138W, DM54139W, DM74S138N or DM74S139N**  
See Package Number J16A, N16E or W16A

<b>Absolute Maximum Ratings</b> (Note 1)	DM54S	-55° C to +125° C
Supply Voltage	7V	0° C to +70° C
Input Voltage	5.5V	-65° C to +150° C
Operating Free Air Temperature Range	Storage Temperature Range	

## Recommended Operating Conditions

Symbol	Parameter	DM54S138,S139			DM74S138,S139			Units
		Min	Nom	Max	Min	Nom	Max	
V <sub>CC</sub>	Supply Voltage	4.5	5	5.5	4.75	5	5.25	V
V <sub>IH</sub>	High Level Input Voltage	2			2			V
V <sub>IL</sub>	Low Level Input Voltage			0.8			0.8	V
I <sub>OH</sub>	High Level Output Current			-1			-1	mA
I <sub>OL</sub>	Low Level Output Current			20			20	mA
T <sub>A</sub>	Free Air Operating Temperature	-55		125	0		70	°C

**Note 1:** The "Absolute Maximum Ratings" are those values beyond which the safety of the device cannot be guaranteed. The device should not be operated at these limits. The parametric values defined in the "Electrical Characteristics" table are not guaranteed at the absolute maximum ratings. The "Recommended Operating Conditions" table will define the conditions for actual device operation.

## Electrical Characteristics

over recommended operating free air temperature (unless otherwise noted)

Symbol	Parameter	Conditions	Min	Typ (Note 2)	Max	Units
V <sub>I</sub>	Input Clamp Voltage	V <sub>CC</sub> = Min, I <sub>I</sub> = -18 mA			-1.2	V
V <sub>OH</sub>	High Level Output Voltage	V <sub>CC</sub> = Min, I <sub>OH</sub> = Max	DM54	2.5	3.4	V
		V <sub>IL</sub> = Max, V <sub>IH</sub> = Min	DM74	2.7	3.4	
V <sub>OL</sub>	Low Level Output Voltage	V <sub>CC</sub> = Min, I <sub>OL</sub> = Max V <sub>IH</sub> = Min, V <sub>IL</sub> = Max			0.5	V
I <sub>I</sub>	Input Current @ Max Input Voltage	V <sub>CC</sub> = Max, V <sub>I</sub> = 5.5V			1	mA
I <sub>IH</sub>	High Level Input Current	V <sub>CC</sub> = Max, V <sub>I</sub> = 2.7V			50	µA
I <sub>IL</sub>	Low Level Input Current	V <sub>CC</sub> = Max, V <sub>I</sub> = 0.5V			-2	mA
I <sub>OS</sub>	Short Circuit Output Current	V <sub>CC</sub> = Max	DM54	-40	-100	mA
		(Note 3)	DM74	-40	-100	
I <sub>CC</sub>	Supply Current (S138)	V <sub>CC</sub> = Max (Note 4)		49	74	mA
I <sub>CC</sub>	Supply Current (S139)	V <sub>CC</sub> = Max (Note 4)		60	90	mA

**Note 2:** All typicals are at V<sub>CC</sub> = 5V, T<sub>A</sub> = 25° C.

**Note 3:** Not more than one output should be shorted at a time, and the duration should not exceed one second.

**Note 4:** I<sub>CC</sub> is measured with all outputs enabled and open.

## 'S138 Switching Characteristics

at V<sub>CC</sub> = 5V and T<sub>A</sub> = 25° C (See Section 1 for Test Waveforms and Output Load)

Symbol	Parameter	From (Input) to (Output)	Levels of Delay	R <sub>L</sub> = 280Ω				Units
				C <sub>L</sub> = 15 pF		C <sub>L</sub> = 50 pF		
				Min	Max	Min	Max	
t <sub>PLH</sub>	Propagation Delay Time Low to High Level Output	Select to Output	2		7		9	ns
t <sub>PHL</sub>	Propagation Delay Time High to Low Level Output	Select to Output	2		10.5		14	ns
t <sub>PLH</sub>	Propagation Delay Time Low to High Level Output	Select to Output	3		12		14	ns

### 'S138 Switching Characteristics (Continued)

at  $V_{CC} = 5V$  and  $T_A = 25^\circ C$  (See Section 1 for Test Waveforms and Output Load)

Symbol	Parameter	From (Input) to (Output)	Levels of Delay	$R_L = 280\Omega$				Units
				$C_L = 15\text{ pF}$		$C_L = 50\text{ pF}$		
				Min	Max	Min	Max	
$t_{PHL}$	Propagation Delay Time High to Low Level Output	Select to Output	3		12		15	ns
$t_{PLH}$	Propagation Delay Time Low to High Level Output	Enable to Output	2		8		10	ns
$t_{PHL}$	Propagation Delay Time High to Low Level Output	Enable to Output	2		11		14	ns
$t_{PLH}$	Propagation Delay Time Low to High Level Output	Enable to Output	3		11		13	ns
$t_{PHL}$	Propagation Delay Time High to Low Level Output	Enable to Output	3		11		14	ns

### 'S139 Switching Characteristics

at  $V_{CC} = 5V$  and  $T_A = 25^\circ C$  (See Section 1 for Test Waveforms and Output Load)

Symbol	Parameter	From (Input) to (Output)	Levels of Delay	$R_L = 280\Omega$				Units
				$C_L = 15\text{ pF}$		$C_L = 50\text{ pF}$		
				Min	Max	Min	Max	
$t_{PLH}$	Propagation Delay Time Low to High Level Output	Select to Output	2		7.5		10	ns
$t_{PHL}$	Propagation Delay Time High to Low Level Output	Select to Output	2		10		13	ns
$t_{PLH}$	Propagation Delay Time Low to High Level Output	Select to Output	3		12		13	ns
$t_{PHL}$	Propagation Delay Time High to Low Level Output	Select to Output	3		12		15	ns
$t_{PLH}$	Propagation Delay Time Low to High Level Output	Enable to Output	2		8		10	ns
$t_{PHL}$	Propagation Delay Time High to Low Level Output	Enable to Output	2		10		13	ns

## Function Tables

### S138

Inputs					Outputs							
Enable		Select			Y0	Y1	Y2	Y3	Y4	Y5	Y6	Y7
G1	G2*	C	B	A								
X	H	X	X	X	H	H	H	H	H	H	H	H
L	X	X	X	X	H	H	H	H	H	H	H	H
H	L	L	L	L	H	H	H	H	H	H	H	H
H	L	L	L	H	H	L	H	H	H	H	H	H
H	L	L	H	L	H	H	L	H	H	H	H	H
H	L	L	H	H	H	H	H	L	H	H	H	H
H	L	H	L	L	H	H	H	H	L	H	H	H
H	L	H	L	H	H	H	H	H	L	H	H	H
H	L	H	H	L	H	H	H	H	H	L	H	H
H	L	H	H	H	H	H	H	H	H	L	H	L

\* G2 = G2A + G2B

H = high level, L = low level, X = don't care (either low or high logic level)

### S139

Inputs			Outputs			
Enable	Select		Y0	Y1	Y2	Y3
G	B	A				
H	X	X	H	H	H	H
L	L	L	L	H	H	H
L	L	H	H	L	H	H
L	H	L	H	H	L	H
L	H	H	H	H	H	L

Note 5: H = high level, L = low level, X = don't care (either low or high logic level)

## Logic Diagrams

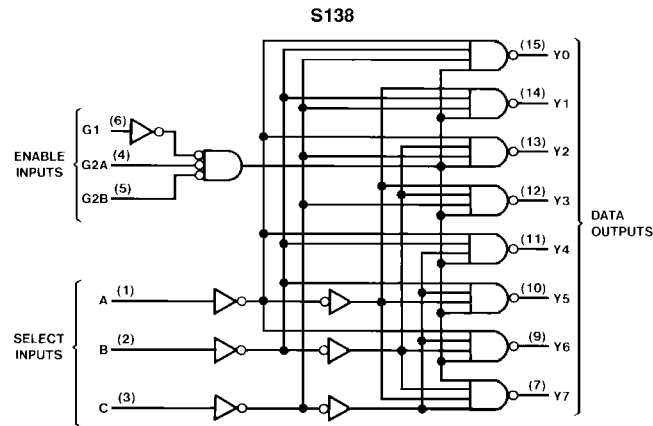

DS005466-3

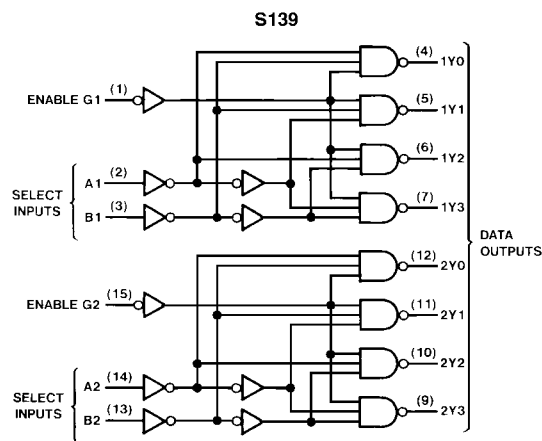

DS005466-4

**Physical Dimensions** inches (millimeters) unless otherwise noted

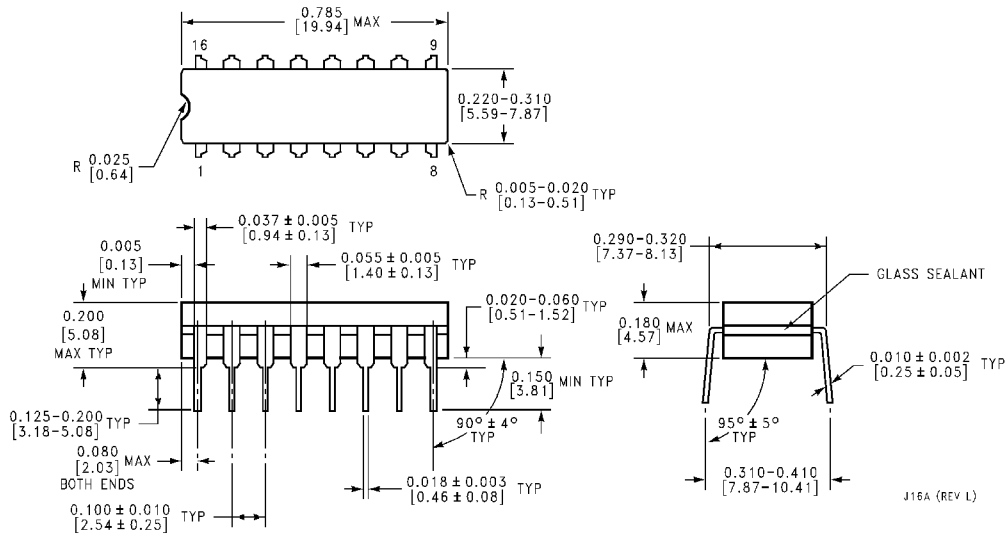

**16-Lead Ceramic Dual-In-Line Package (J)**  
**Order Number DM54S138J or DM54S139J**  
**Package Number J16A**

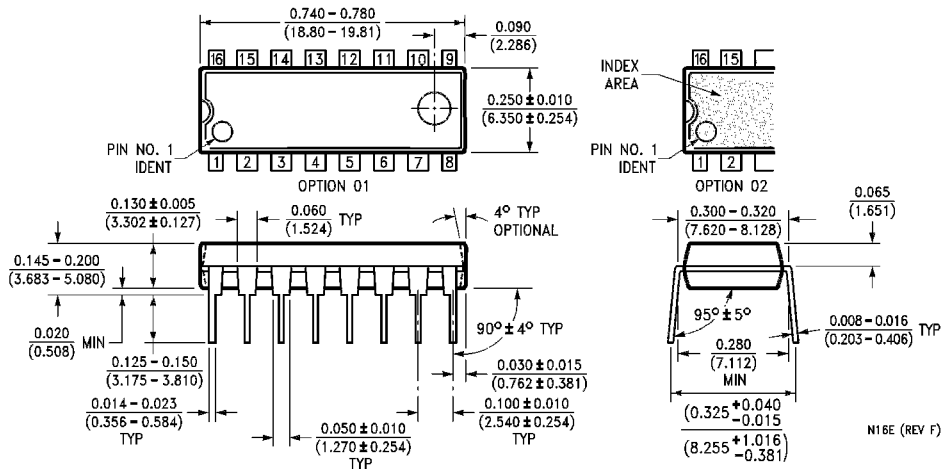

**16-Lead Molded Dual-In-Line Package (N)**  
**Order Number DM74S138N or DM74S139N**  
**Package Number N16E**

**Physical Dimensions** inches (millimeters) unless otherwise noted (Continued)

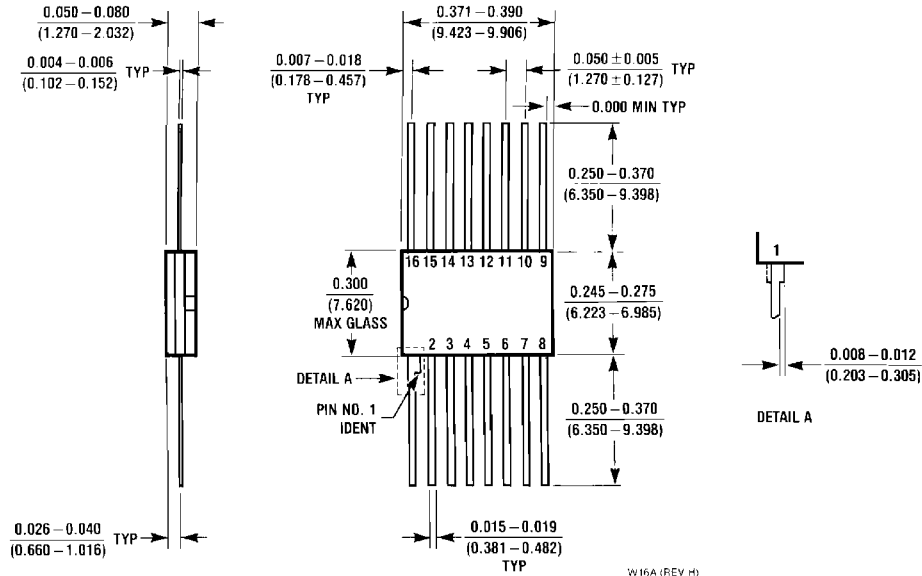

**16-Lead Ceramic Flat Package (W)**  
**Order Number DM54S138W or DM54S139W**  
**Package Number W16A**

**LIFE SUPPORT POLICY**

FAIRCHILD'S PRODUCTS ARE NOT AUTHORIZED FOR USE AS CRITICAL COMPONENTS IN LIFE SUPPORT DEVICES OR SYSTEMS WITHOUT THE EXPRESS WRITTEN APPROVAL OF THE PRESIDENT OF FAIRCHILD SEMICONDUCTOR CORPORATION. As used herein:

1. Life support devices or systems are devices or systems which, (a) are intended for surgical implant into the body, or (b) support or sustain life, and (c) whose failure to perform when properly used in accordance with instructions for use provided in the labeling, can be reasonably expected to result in a significant injury to the user.
2. A critical component in any component of a life support device or system whose failure to perform can be reasonably expected to cause the failure of the life support device or system, or to affect its safety or effectiveness.

Fairchild Semiconductor  
 Corporation  
**Americas**  
 Customer Response Center  
 Tel: 1-888-522-5372

Fairchild Semiconductor  
**Europe**  
 Fax: +49 (0) 1 80-530 85 86  
 Email: europe.support@nsc.com  
 Deutsch Tel: +49 (0) 8 141-35-0  
 English Tel: +44 (0) 1 793-85-68-56  
 Italy Tel: +39 (0) 2 57 5631

Fairchild Semiconductor  
**Hong Kong Ltd.**  
 13th Floor, Straight Block,  
 Ocean Centre, 5 Canton Rd.  
 Tsimshatsui, Kowloon  
 Hong Kong  
 Tel: +852 2737-7200  
 Fax: +852 2314-0061

**National Semiconductor  
 Japan Ltd.**  
 Tel: 81-3-5620-6175  
 Fax: 81-3-5620-6179

www.fairchildsemi.com