



# OP-90

## PRECISION LOW-VOLTAGE MICROPOWER OPERATIONAL AMPLIFIER

Precision Monolithics Inc.

### FEATURES

- **Single/Dual Supply Operation** ..... +1.6V to +36V  
.....  $\pm 0.8V$  to  $\pm 18V$
- **True Single-Supply Operation; Input and Output Voltage Ranges Include Ground**
- **Low Supply Current** ..... 20 $\mu$ A Max
- **High Output Drive** ..... 5mA Min
- **Low Input Offset Voltage** ..... 150 $\mu$ V Max
- **High Open-Loop Gain** ..... 700V/mV Min
- **Outstanding PSRR** ..... 5.6 $\mu$ V/V Max
- **Standard 741 Pinout With Nulling to V-**
- **Available in Die Form**

### GENERAL DESCRIPTION

The OP-90 is a high performance micropower op amp that operates from a single supply of +1.6V to +36V or from dual supplies of  $\pm 0.8$  to  $\pm 18V$ . Input voltage range includes the negative rail allowing the OP-90 to accommodate input signals down to ground in single supply operation. The OP-90's output swing also includes ground when operating from a single supply, enabling "zero-in, zero-out" operation.

The OP-90 draws less than 20 $\mu$ A of quiescent supply current, while able to deliver over 5mA of output current to a load. Input offset voltage is below 150 $\mu$ V eliminating the need for external nulling. Gain exceeds 700,000 and common-mode rejection is better than 100dB. The power supply-rejection ratio of under 5.6 $\mu$ V/V minimizes offset voltage changes experienced in battery powered systems.

The low offset voltage and high gain offered by the OP-90 bring precision performance to micropower applications. The minimal voltage and current requirements of the OP-90

suit it for battery and solar powered applications, such as portable instruments, remote sensors, and satellites.

### ORDERING INFORMATION <sup>†</sup>

| T <sub>A</sub> = 25°C<br>V <sub>OS</sub> MAX<br>(mV) | PACKAGE         |                      |                   | OPERATING TEMPERATURE RANGE |
|--|-----------------|----------------------|-------------------|-----------------------------|
|  | CERDIP<br>8-PIN | PLASTIC<br>8-PIN     | LCC<br>20-CONTACT |                             |
| 150  | OP90AZ*         | -                    | OP90ARC/883       | MIL                         |
| 150  | OP90EZ          | -                    | -                 | IND                         |
| 250  | OP90FZ          | -                    | -                 | IND                         |
| 450  | -               | OP90GP               | -                 | XIND                        |
| 450  | -               | OP90GS <sup>††</sup> | -                 | XIND                        |

\* For devices processed in total compliance to MIL-STD-883, add /883 after part number. Consult factory for 883 data sheet.

<sup>†</sup> Burn-in is available on commercial and industrial temperature range parts in CerDIP, plastic DIP, and TO-can packages. For ordering information, see 1990/91 Data Book, Section 2.

<sup>††</sup> For availability and burn-in information on SO and PLCC packages, contact your local sales office.

### PIN CONNECTIONS

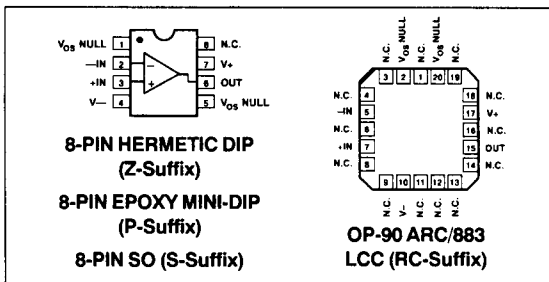

### SIMPLIFIED SCHEMATIC

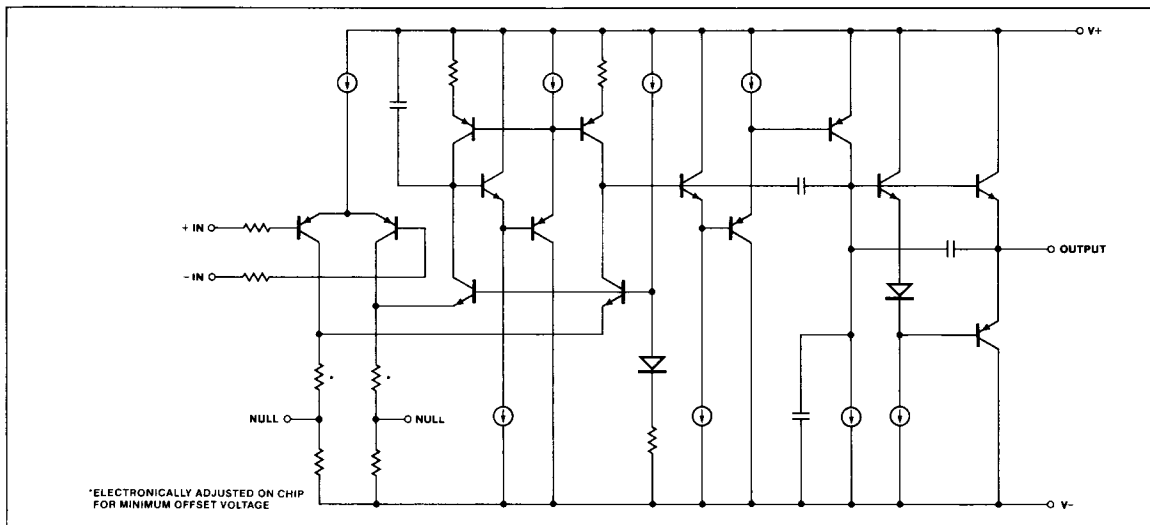



**ABSOLUTE MAXIMUM RATINGS** (Note 1)

Supply Voltage ..... ±18V  
 Differential Input Voltage ..... [(V-) - 20V] to [(V+) + 20V]  
 Common-Mode Input Voltage ..... [(V-) - 20V] to [(V+) + 20V]  
 Output Short-Circuit Duration ..... Indefinite  
 Storage Temperature Range .....  
 Z Package ..... -65°C to +150°C  
 P Package ..... -65°C to +150°C  
 Operating Temperature Range .....  
 OP-90A ..... -55°C to +125°C  
 OP-90E, OP-90F ..... -25°C to +85°C  
 OP-90G ..... -40°C to +85°C

Junction Temperature (T<sub>j</sub>) ..... -65°C to +150°C  
 Lead Temperature (Soldering, 60 sec) ..... +300°C

| PACKAGE TYPE           | θ <sub>JA</sub> (Note 2) | θ <sub>JC</sub> | UNITS |
|------------------------|--------------------------|-----------------|-------|
| 8-Pin Hermetic DIP (Z) | 148                      | 16              | °C/W  |
| 8-Pin Plastic DIP (P)  | 103                      | 43              | °C/W  |
| 20-Contact LCC (RC)    | 98                       | 38              | °C/W  |
| 8-Pin SO (S)           | 158                      | 43              | °C/W  |

**NOTES:**

1. Absolute maximum ratings apply to both DICE and packaged parts, unless otherwise noted.
2. θ<sub>JA</sub> is specified for worst case mounting conditions, i.e., θ<sub>JA</sub> is specified for device in socket for CerDIP, P-DIP, and LCC packages; θ<sub>JA</sub> is specified for device soldered to printed circuit board for SO package.

**ELECTRICAL CHARACTERISTICS** at V<sub>S</sub> = ±1.5V to ±15V, T<sub>A</sub> = +25°C, unless otherwise noted.

| PARAMETER                          | SYMBOL            | CONDITIONS   | OP-90A/E |       |     | OP-90F |       |     | OP-90G |       |     | UNITS             |
|------------------------------------|-------------------|--|----------|-------|-----|--------|-------|-----|--------|-------|-----|-------------------|
|                                    |                   |  | MIN      | TYP   | MAX | MIN    | TYP   | MAX | MIN    | TYP   | MAX |                   |
| Input Offset Voltage               | V <sub>OS</sub>   |  | —        | 50    | 150 | —      | 75    | 250 | —      | 125   | 450 | μV                |
| Input Offset Current               | I <sub>OS</sub>   | V <sub>CM</sub> = 0V   | —        | 0.4   | 3   | —      | 0.4   | 5   | —      | 0.4   | 5   | nA                |
| Input Bias Current                 | I <sub>B</sub>    | V <sub>CM</sub> = 0V   | —        | 4.0   | 15  | —      | 4.0   | 20  | —      | 4.0   | 25  | nA                |
| Large Signal Voltage Gain          | A <sub>VO</sub>   | V <sub>S</sub> = ±15V, V <sub>O</sub> = ±10V                               |          |       |     |        |       |     |        |       |     |                   |
|                                    |                   | R <sub>L</sub> = 100kΩ   | 700      | 1200  | —   | 500    | 1000  | —   | 400    | 800   | —   |                   |
|                                    |                   | R <sub>L</sub> = 10kΩ  | 350      | 600   | —   | 250    | 500   | —   | 200    | 400   | —   |                   |
|                                    |                   | R <sub>L</sub> = 2kΩ   | 125      | 250   | —   | 100    | 200   | —   | 100    | 200   | —   | V/mV              |
|                                    |                   | V <sub>+</sub> = 5V, V <sub>-</sub> = 0V,<br>1V < V <sub>O</sub> < 4V      |          |       |     |        |       |     |        |       |     |                   |
|                                    |                   | R <sub>L</sub> = 100kΩ   | 200      | 400   | —   | 125    | 300   | —   | 100    | 250   | —   |                   |
|                                    |                   | R <sub>L</sub> = 10kΩ  | 100      | 180   | —   | 75     | 140   | —   | 70     | 140   | —   |                   |
| Input Voltage Range                | IVR               | V <sub>+</sub> = 5V, V <sub>-</sub> = 0V<br>V <sub>S</sub> = ±15V (Note 2) | 0/4      | —     | —   | 0/4    | —     | —   | 0/4    | —     | —   | V                 |
| Output Voltage Swing               | V <sub>O</sub>    | V <sub>S</sub> = ±15V  | ±14      | ±14.2 | —   | ±14    | ±14.2 | —   | ±14    | ±14.2 | —   | V                 |
|                                    |                   | R <sub>L</sub> = 10kΩ  | ±11      | ±12   | —   | ±11    | ±12   | —   | ±11    | ±12   | —   |                   |
|                                    |                   | R <sub>L</sub> = 2kΩ   | ±11      | ±12   | —   | ±11    | ±12   | —   | ±11    | ±12   | —   |                   |
|                                    | V <sub>OH</sub>   | V <sub>+</sub> = 5V, V <sub>-</sub> = 0V<br>R <sub>L</sub> = 2kΩ           | 4.0      | 4.2   | —   | 4.0    | 4.2   | —   | 4.0    | 4.2   | —   | V                 |
|                                    | V <sub>OL</sub>   | V <sub>+</sub> = 5V, V <sub>-</sub> = 0V<br>R <sub>L</sub> = 10kΩ          | —        | 100   | 500 | —      | 100   | 500 | —      | 100   | 500 | μV                |
| Common Mode Rejection              | CMR               | V <sub>+</sub> = 5V, V <sub>-</sub> = 0V,<br>0V < V <sub>CM</sub> < 4V     | 90       | 110   | —   | 80     | 100   | —   | 80     | 100   | —   | dB                |
|                                    |                   | V <sub>S</sub> = ±15V,<br>-15V < V <sub>CM</sub> < 13.5V                   | 100      | 130   | —   | 90     | 120   | —   | 90     | 120   | —   |                   |
| Power Supply Rejection Ratio       | PSRR              |  | —        | 1.0   | 5.6 | —      | 1.0   | 5.6 | —      | 3.2   | 10  | μV/V              |
| Slew Rate                          | SR                | V <sub>S</sub> = ±15V  | 5        | 12    | —   | 5      | 12    | —   | 5      | 12    | —   | V/ms              |
| Supply Current                     | I <sub>SY</sub>   | V <sub>S</sub> = ±1.5V   | —        | 9     | 15  | —      | 9     | 15  | —      | 9     | 15  | μA                |
|                                    |                   | V <sub>S</sub> = ±15V  | —        | 14    | 20  | —      | 14    | 20  | —      | 14    | 20  |                   |
| Capacitive Load Stability          |                   | A <sub>V</sub> = +1<br>No Oscillations<br>(Note 1)                         | 250      | 650   | —   | 250    | 650   | —   | 250    | 650   | —   | pF                |
| Input Noise Voltage                | e <sub>np-p</sub> | f <sub>O</sub> = 0.1Hz to 10Hz<br>V <sub>S</sub> = ±15V                    | —        | 3     | —   | —      | 3     | —   | —      | 3     | —   | μV <sub>p-p</sub> |
| Input Resistance Differential Mode | R <sub>IN</sub>   | V <sub>S</sub> = ±15V  | —        | 30    | —   | —      | 30    | —   | —      | 30    | —   | MΩ                |
| Input Resistance Common Mode       | R <sub>INCM</sub> | V <sub>S</sub> = ±15V  | —        | 20    | —   | —      | 20    | —   | —      | 20    | —   | GΩ                |

**NOTES:**

1. Guaranteed but not 100% tested.
2. Guaranteed by CMR test.

**ELECTRICAL CHARACTERISTICS** at  $V_S = \pm 1.5V$  to  $\pm 15V$ ,  $-55^\circ C \leq T_A \leq 125^\circ C$ , unless otherwise noted.

| PARAMETER                          | SYMBOL     | CONDITIONS   | OP-90A                   |                          |        | UNITS            |
|------------------------------------|------------|--|--------------------------|--------------------------|--------|------------------|
|                                    |            |  | MIN                      | TYP                      | MAX    |                  |
| Input Offset Voltage               | $V_{OS}$   |  | —                        | 80                       | 400    | $\mu V$          |
| Average Input Offset Voltage Drift | $TCV_{OS}$ |  | —                        | 0.3                      | 2.5    | $\mu V/^\circ C$ |
| Input Offset Current               | $I_{OS}$   | $V_{CM} = 0V$  | —                        | 1.5                      | 5      | nA               |
| Input Bias Current                 | $I_B$      | $V_{CM} = 0V$  | —                        | 4.0                      | 20     | nA               |
| Large Signal Voltage Gain          | $A_{VO}$   | $V_S = \pm 15V, V_O = \pm 10V$                           |                          |                          |        | V/mV             |
|                                    |            | $R_L = 100k\Omega$                                       | 225                      | 400                      | —      |                  |
|                                    |            | $R_L = 10k\Omega$  | 125                      | 240                      | —      |                  |
|                                    |            | $R_L = 2k\Omega$   | 50                       | 110                      | —      |                  |
|                                    |            | $V_+ = 5V, V_- = 0V,$<br>$1V < V_O < 4V$                 |                          |                          |        |                  |
|                                    |            | $R_L = 100k\Omega$                                       | 100                      | 200                      | —      |                  |
|                                    |            | $R_L = 10k\Omega$  | 50                       | 110                      | —      |                  |
| Input Voltage Range                | IVR        | $V_+ = 5V, V_- = 0V$ (Note 1)<br>$V_S = \pm 15V$         | 0/3.5<br>-15/13.5        | —<br>—                   | —<br>— | V                |
| Output Voltage Swing               | $V_O$      | $V_S = \pm 15V$<br>$R_L = 10k\Omega$<br>$R_L = 2k\Omega$ | $\pm 13.5$<br>$\pm 10.5$ | $\pm 13.7$<br>$\pm 11.5$ | —<br>— | V                |
|                                    | $V_{OH}$   | $V_+ = 5V, V_- = 0V$<br>$R_L = 2k\Omega$                 | 3.9                      | 4.1                      | —      | V                |
|                                    | $V_{OL}$   | $V_+ = 5V, V_- = 0V$<br>$R_L = 10k\Omega$                | —                        | 100                      | 500    | $\mu V$          |
| Common Mode Rejection              | CMR        | $V_+ = 5V, V_- = 0V, 0V < V_{CM} < 3.5V$                 | 85                       | 105                      | —      | dB               |
|                                    |            | $V_S = \pm 15V, -15V < V_{CM} < 13.5V$                   | 95                       | 115                      | —      |                  |
| Power Supply Rejection Ratio       | PSRR       |  | —                        | 3.2                      | 10     | $\mu V/V$        |
| Supply Current                     | $I_{SY}$   | $V_S = \pm 1.5V$   | —                        | 15                       | 25     | $\mu A$          |
|                                    |            | $V_S = \pm 15V$  | —                        | 19                       | 30     |                  |

**NOTE:**

1. Guaranteed by CMR test.



**ELECTRICAL CHARACTERISTICS** at  $V_S = \pm 1.5V$  to  $\pm 15V$ ,  $-25^\circ C \leq T_A \leq +85^\circ C$  for OP-90E/F,  $-40^\circ C \leq T_A \leq +85^\circ C$  for OP-90G, unless otherwise noted.

| PARAMETER                          | SYMBOL     | CONDITIONS   | OP-90E     |            |     | OP-90F     |            |     | OP-90G     |            |      | UNITS            |
|------------------------------------|------------|--|------------|------------|-----|------------|------------|-----|------------|------------|------|------------------|
|                                    |            |  | MIN        | TYP        | MAX | MIN        | TYP        | MAX | MIN        | TYP        | MAX  |                  |
| Input Offset Voltage               | $V_{OS}$   |  | —          | 70         | 270 | —          | 110        | 550 | —          | 180        | 675  | $\mu V$          |
| Average Input Offset Voltage Drift | $TCV_{OS}$ |  | —          | 0.3        | 2   | —          | 0.6        | 5   | —          | 1.2        | 5    | $\mu V/^\circ C$ |
| Input Offset Current               | $I_{OS}$   | $V_{CM} = 0V$  | —          | 0.8        | 3   | —          | 1.0        | 5   | —          | 1.3        | 7    | nA               |
| Input Bias Current                 | $I_B$      | $V_{CM} = 0V$  | —          | 4.0        | 15  | —          | 4.0        | 20  | —          | 4.0        | 25   | nA               |
| Large Signal Voltage Gain          | $A_{VO}$   | $V_S = \pm 15V$ , $V_O = \pm 10V$<br>$R_L = 100k\Omega$            | 500        | 800        | —   | 350        | 700        | —   | 300        | 600        | —    | V/mV             |
|                                    |            | $R_L = 10k\Omega$  | 250        | 400        | —   | 175        | 350        | —   | 150        | 250        | —    |                  |
|                                    |            | $R_L = 2k\Omega$   | 100        | 200        | —   | 75         | 150        | —   | 75         | 125        | —    |                  |
|                                    |            | $V_+ = 5V$ , $V_- = 0V$ ,<br>$1V < V_O < 4V$<br>$R_L = 100k\Omega$ | 150        | 280        | —   | 100        | 220        | —   | 80         | 160        | —    |                  |
|                                    |            | $R_L = 10k\Omega$  | 75         | 140        | —   | 50         | 110        | —   | 40         | 90         | —    |                  |
| Input Voltage Range                | IVR        | $V_+ = 5V$ , $V_- = 0V$  | 0/3.5      | —          | —   | 0/3.5      | —          | —   | 0/3.5      | —          | —    | V                |
|                                    |            | $V_S = \pm 15V$ (Note 1)   | -15/13.5   | —          | —   | -15/13.5   | —          | —   | -15/13.5   | —          | —    |                  |
| Output Voltage Swing               | $V_O$      | $V_S = \pm 15V$<br>$R_L = 10k\Omega$                               | $\pm 13.5$ | $\pm 14$   | —   | $\pm 13.5$ | $\pm 14$   | —   | $\pm 13.5$ | $\pm 14$   | —    | V                |
|                                    |            | $R_L = 2k\Omega$   | $\pm 10.5$ | $\pm 11.8$ | —   | $\pm 10.5$ | $\pm 11.8$ | —   | $\pm 10.5$ | $\pm 11.8$ | —    |                  |
|                                    |            | $V_+ = 5V$ , $V_- = 0V$<br>$R_L = 2k\Omega$                        | 3.9        | 4.1        | —   | 3.9        | 4.1        | —   | 3.9        | 4.1        | —    | V                |
|                                    | $V_{OL}$   | $V_+ = 5V$ , $V_- = 0V$<br>$R_L = 10k\Omega$                       | —          | 100        | 500 | —          | 100        | 500 | —          | 100        | 500  | $\mu V$          |
| Common Mode Rejection              | CMR        | $V_+ = 5V$ , $V_- = 0V$ ,<br>$0V < V_{CM} < 3.5V$                  | 90         | 110        | —   | 80         | 100        | —   | 80         | 100        | —    | dB               |
|                                    |            | $V_S = \pm 15V$ ,<br>$-15V < V_{CM} < 13.5V$                       | 100        | 120        | —   | 90         | 110        | —   | 90         | 110        | —    |                  |
| Power Supply Rejection Ratio       | PSRR       |  | —          | 1.0        | 5.6 | —          | 3.2        | 10  | —          | 5.6        | 17.8 | $\mu V/V$        |
| Supply Current                     | $I_{SY}$   | $V_S = \pm 1.5V$   | —          | 13         | 25  | —          | 13         | 25  | —          | 12         | 25   | $\mu A$          |
|                                    |            | $V_S = \pm 15V$  | —          | 17         | 30  | —          | 17         | 30  | —          | 16         | 30   |                  |

**NOTE:**

1. Guaranteed by CMR test.

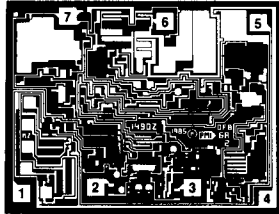
**DICE CHARACTERISTICS**

**DIE SIZE** 0.086 × 0.067 inch, 5762 sq. mils  
(2.18 × 1.70mm, 3.71 sq. mm)

1.  $V_{OS}$  NULL
2. -IN
3. +IN
4. V-
5.  $V_{OS}$  NULL
6. OUT
7. V+

For additional DICE ordering information, refer to 1990/91 Data Book, Section 2.

**WAFER TEST LIMITS** at  $V_S = \pm 1.5V$  to  $\pm 15V$ ,  $T_A = 25^\circ C$ , unless otherwise noted.

| PARAMETER                    | SYMBOL   | CONDITIONS   | OP-90GBC             |               |
|------------------------------|----------|--|----------------------|---------------|
|                              |          |  | LIMIT                | UNITS         |
| Input Offset Voltage         | $V_{OS}$ |  | 250                  | $\mu V$ MAX   |
| Input Offset Current         | $I_{OS}$ | $V_{CM} = 0V$  | 5                    | nA MAX        |
| Input Bias Current           | $I_B$    | $V_{CM} = 0V$  | 20                   | nA MAX        |
| Large Signal Voltage Gain    | $A_{VO}$ | $V_S = \pm 15V, V_O = \pm 10V$<br>$R_L = 100k\Omega$           | 500                  | V/mV MIN      |
|                              |          | $R_L = 10k\Omega$  | 250                  |               |
|                              |          | $V_+ = 5V, V_- = 0V,$<br>$1V < V_O < 4V$<br>$R_L = 100k\Omega$ | 125                  | V/mV MIN      |
| Input Voltage Range          | IVR      | $V_+ = 5V, V_- = 0V$<br>$V_S = \pm 15V$ (Note 1)               | 0/4<br>-15/13.5      | V MIN         |
| Output Voltage Swing         | $V_O$    | $V_S = \pm 15V$<br>$R_L = 10k\Omega$<br>$R_L = 2k\Omega$       | $\pm 14$<br>$\pm 11$ | V MIN         |
|                              | $V_{OH}$ | $V_+ = 5V, V_- = 0V$<br>$R_L = 2k\Omega$                       | 4.0                  | V MIN         |
|                              | $V_{OL}$ | $V_+ = 5V, V_- = 0V$<br>$R_L = 10k\Omega$                      | 500                  | $\mu V$ MAX   |
| Common Mode Rejection        | CMR      | $V_+ = 5V, V_- = 0V, 0V < V_{CM} < 4V$                         | 80                   | dB MIN        |
|                              |          | $V_S = \pm 15V, -15V < V_{CM} < 13.5V$                         | 90                   |               |
| Power Supply Rejection Ratio | PSRR     |  | 10                   | $\mu V/V$ MAX |
| Supply Current               | $I_{SY}$ | $V_S = \pm 15V$  | 20                   | $\mu A$ MAX   |

**NOTES:**

1. Guaranteed by CMR test.

Electrical tests are performed at wafer probe to the limits shown. Due to variations in assembly methods and normal yield loss, yield after packaging is not guaranteed for standard product dice. Consult factory to negotiate specifications based on dice lot qualification through sample lot assembly and testing.

## TYPICAL PERFORMANCE CHARACTERISTICS

INPUT OFFSET VOLTAGE vs TEMPERATURE

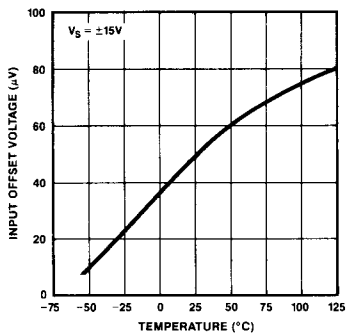

INPUT OFFSET CURRENT vs TEMPERATURE

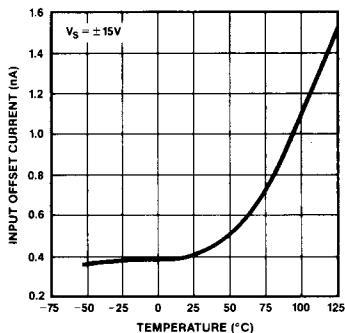

INPUT BIAS CURRENT vs TEMPERATURE

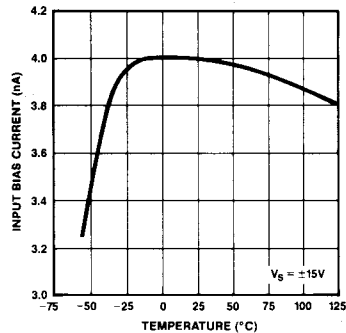

SUPPLY CURRENT vs TEMPERATURE

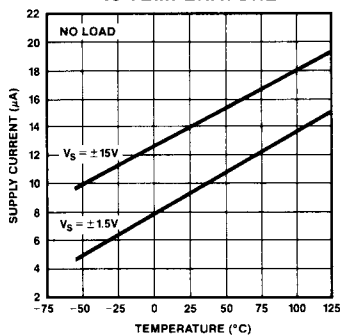

OPEN-LOOP GAIN vs SINGLE-SUPPLY VOLTAGE

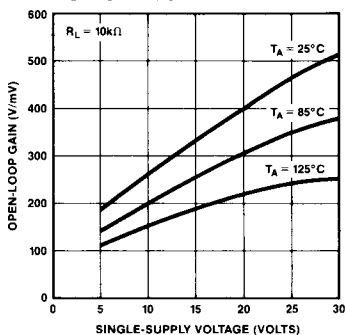

OPEN-LOOP GAIN AND PHASE SHIFT vs FREQUENCY

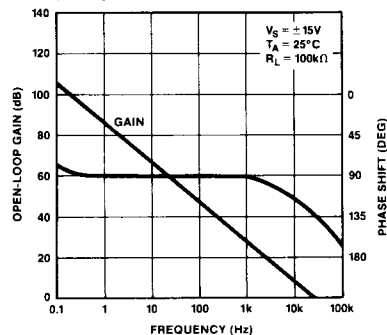

CLOSED-LOOP GAIN vs FREQUENCY

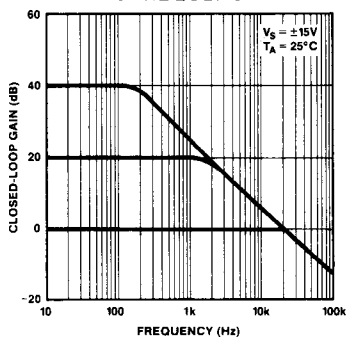

OUTPUT VOLTAGE SWING vs LOAD RESISTANCE

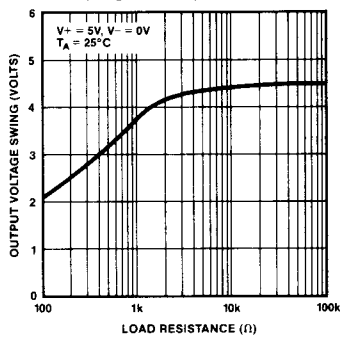

OUTPUT VOLTAGE SWING vs LOAD RESISTANCE

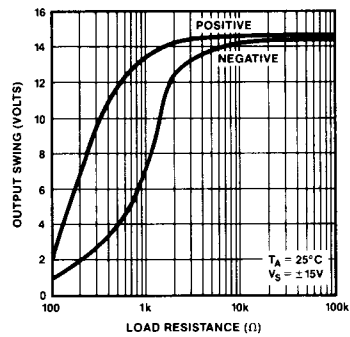

TYPICAL PERFORMANCE CHARACTERISTICS

POWER SUPPLY REJECTION vs FREQUENCY

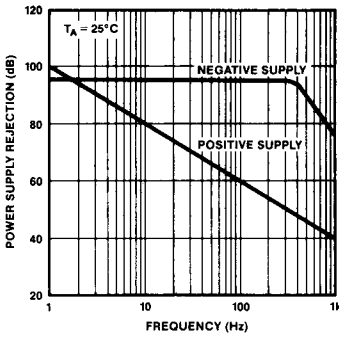

COMMON-MODE REJECTION vs FREQUENCY

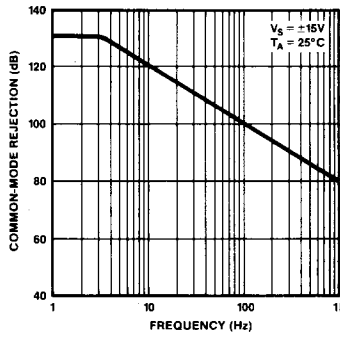

NOISE VOLTAGE DENSITY vs FREQUENCY

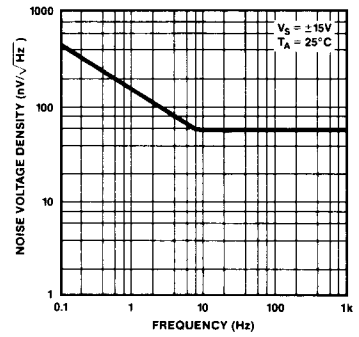

CURRENT NOISE DENSITY vs FREQUENCY

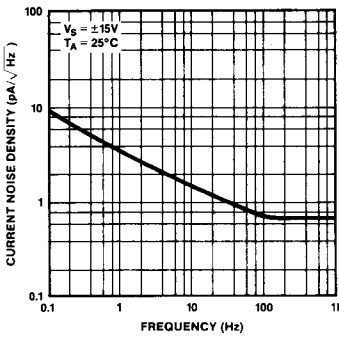

SMALL-SIGNAL TRANSIENT RESPONSE

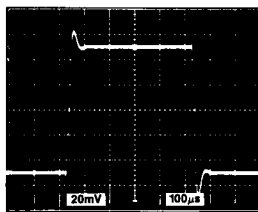

TA = 25°C  
 VS = ±15V  
 AV = +1  
 RL = 10kΩ  
 CL = 500pF

LARGE-SIGNAL TRANSIENT RESPONSE

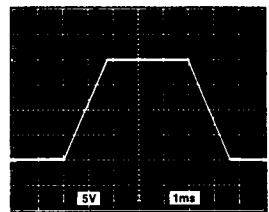

TA = 25°C  
 VS = ±15V  
 AV = +1  
 RL = 10kΩ  
 CL = 500pF

BURN-IN CIRCUIT

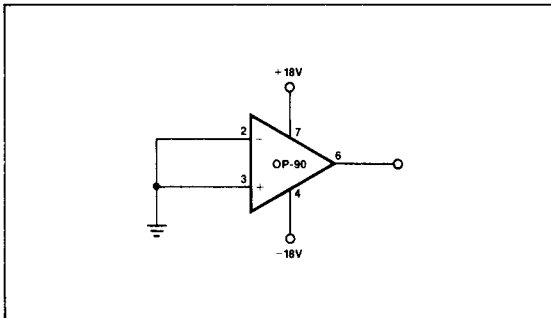

APPLICATIONS INFORMATION

BATTERY-POWERED APPLICATIONS

The OP-90 can be operated on a minimum supply voltage of +1.6V, or with dual supplies ±0.8V, and draws only 14µA of supply current. In many battery-powered circuits, the OP-90 can be continuously operated for thousands of hours before requiring battery replacement, reducing equipment downtime and operating cost.

High-performance portable equipment and instruments frequently use lithium cells because of their long shelf-life, light weight, and high energy density relative to older primary cells. Most lithium cells have a nominal output voltage of 3V and are noted for a flat discharge characteristic. The low supply voltage requirement of the OP-90, combined with the flat discharge characteristic of the lithium cell, indicates that the OP-90 can be operated over the entire useful life of the cell. Figure 1 shows the typical discharge characteristic of a 1Ah lithium cell powering an OP-90 which, in turn, is driving full output swing into a 100kΩ load.

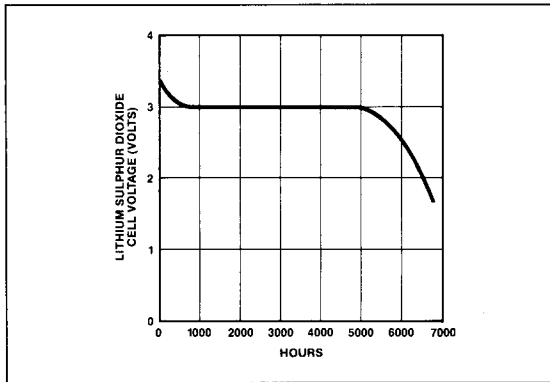

**FIGURE 1:** Lithium Sulphur Dioxide Cell Discharge Characteristic With OP-90 and 100k $\Omega$  Load

### INPUT VOLTAGE PROTECTION

The OP-90 uses a PNP input stage with protection resistors in series with the inverting and noninverting inputs. The high breakdown of the PNP transistors coupled with the protection resistors provides a large amount of input protection, allowing the inputs to be taken 20V beyond either supply without damaging the amplifier.

### OFFSET NULLING

The offset null circuit of Figure 2 provides 6mV of offset adjustment range. A 100k $\Omega$  resistor placed in series with the wiper of the offset null potentiometer, as shown in Figure 3,

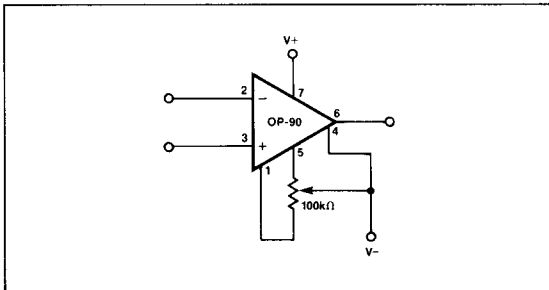
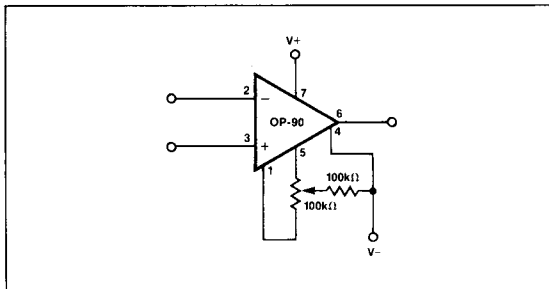
**FIGURE 2:** Offset Nulling Circuit

**FIGURE 3:** High Resolution Offset Nulling Circuit

reduces the offset adjustment range to 400 $\mu$ V and is recommended for applications requiring high null resolution. Offset nulling does not affect TC<sub>V<sub>OS</sub></sub> performance.

### SINGLE-SUPPLY OUTPUT VOLTAGE RANGE

In single-supply operation the OP-90's input and output ranges include ground. This allows true "zero-in, zero-out" operation. The output stage provides an active pull-down to around 0.8V above ground. Below this level, a load resistance of up to 1M $\Omega$  to ground is required to pull the output down to zero.

In the region from ground to 0.8V the OP-90 has voltage gain equal to the data sheet specification. Output current source capability is maintained over the entire voltage range including ground.

## APPLICATIONS

### BATTERY-POWERED VOLTAGE REFERENCE

The circuit of Figure 4 is a battery-powered voltage reference that draws only 17 $\mu$ A of supply current. At this level, two AA cells can power this reference over 18 months. At an output voltage of 1.23V @ 25°C, drift of the reference is only 5.5 $\mu$ V/°C over the industrial temperature range. Load regulation is 85 $\mu$ V/mA with line regulation at 120 $\mu$ V/V.

Design of the reference is based on the bandgap technique. Scaling of resistors R1 and R2 produces unequal currents in Q1 and Q2. The resulting V<sub>BE</sub> mismatch creates a temperature-proportional voltage across R3 which, in turn, produces a larger temperature-proportional voltage across R4 and R5. This voltage appears at the output added to the V<sub>BE</sub> of Q1, which has an opposite temperature coefficient. Adjusting the

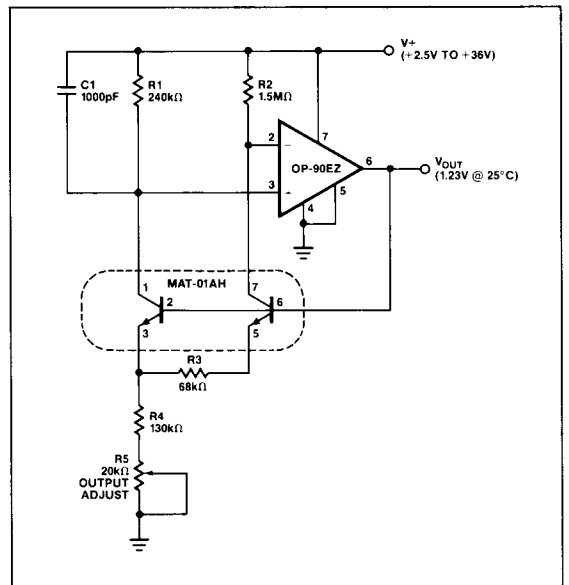
**FIGURE 4:** Battery Powered Voltage Reference



output to 1.23V at 25°C produces minimum drift over temperature. Bandgap references can have start-up problems. With no current in R1 and R2, the OP-90 is beyond its positive input range limit and has an undefined output state. Shorting Pin 5 (an offset adjust pin) to ground forces the output high under these conditions and insures reliable start-up without significantly degrading the OP-90's offset drift.

**SINGLE OP AMP FULL-WAVE RECTIFIER**

Figure 5 shows a full-wave rectifier circuit that provides the absolute value of input signals up to ±2.5V even though operated from a single 5V supply. For negative inputs, the amplifier acts as an unity gain inverter. Positive signals force the op amp output to ground. The 1N914 diode becomes reversed-biased and the signal passes through R1 and R2 to the output. Since output impedance is dependent on input polarity, load impedances cause an asymmetric output. For constant load impedances, this can be corrected by reducing R2. Varying or heavy loads can be buffered by a second OP-90. Figure 6 shows the output of the full-wave rectifier with a 4V<sub>p-p</sub>, 10Hz input signal.

**FIGURE 5:** Single Op-Amp Full Wave Rectifier

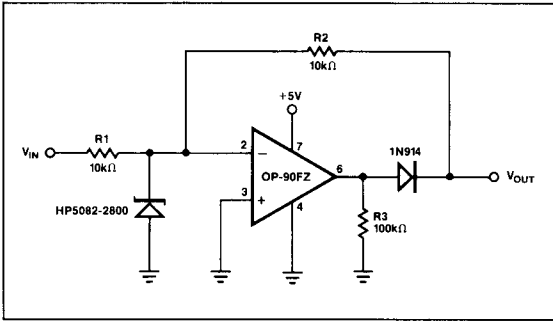

**FIGURE 7:** Two Wire 4-20mA Transmitter

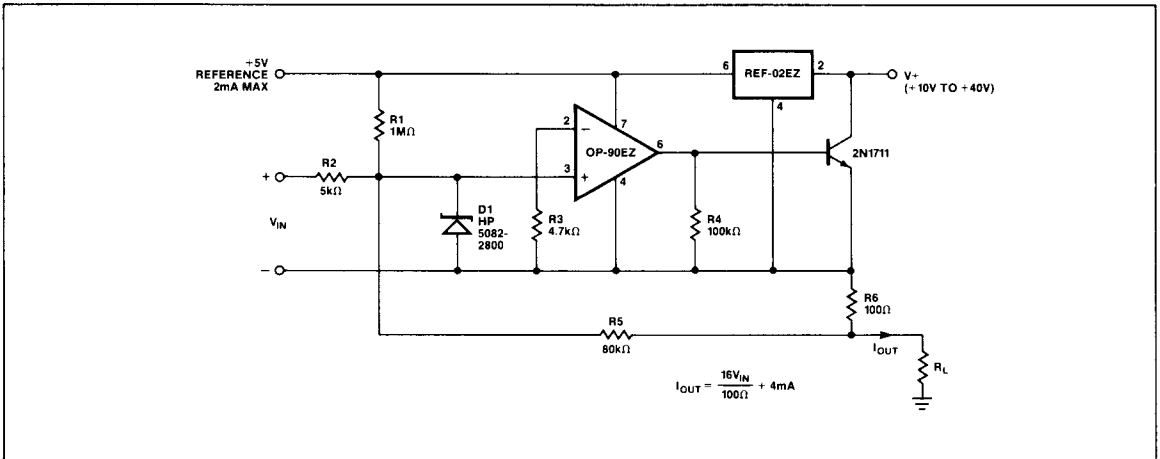

**FIGURE 6:** Output of Full-Wave Rectifier With 4V<sub>p-p</sub>, 10Hz Input

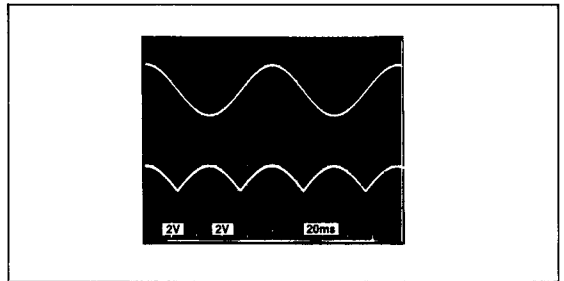

**TWO WIRE 4-20mA CURRENT TRANSMITTER**

The current transmitter of Figure 7 provides an output of 4mA to 20mA that is linearly proportional to the input voltage. Linearity of the transmitter exceeds 0.004% and line rejection is 0.0005%/volt.

Biasing for the current transmitter is provided by the REF-02EZ. The OP-90EZ regulates the output current to satisfy the current summation at the noninverting node:

$$I_{OUT} = \frac{1}{R6} \left( \frac{V_{IN} R5}{R2} + \frac{5V R5}{R1} \right)$$

For the values shown in Figure 7,

$$I_{OUT} = \left( \frac{16}{100\Omega} \right) V_{IN} + 4mA$$

giving a full-scale output of 20mA with a 100mV input. Adjustment of R2 will provide an offset trim and adjustment of R1 will provide a gain trim. These trims do not interact since the noninverting input of the OP-90 is at virtual ground. The Schottky diode, D1, prevents input voltage spikes from pull-

ing the noninverting input more than 300mV below the inverting input. Without the diode, such spikes could cause phase reversal of the OP-90 and possible latch-up of the transmitter. Compliance of this circuit is from 10V to 40V. The voltage reference output can provide up to 2mA for transducer excitation.

**MICROPOWER VOLTAGE-CONTROLLED OSCILLATOR**

Two OP-90s in combination with an inexpensive quad CMOS switch comprise the precision VCO of Figure 8. This circuit provides triangle and square wave outputs and draws only 50µA from a single 5V supply. A1 acts as an integrator; S1 switches the charging current symmetrically to yield positive

and negative ramps. The integrator is bounded by A2 which acts as a Schmitt trigger with a precise hysteresis of 1.67 volts, set by resistors R5, R6, and R7, and associated CMOS switches. The resulting output of A1 is a triangle wave with upper and lower levels of 3.33 and 1.67 volts. The output of A2 is a square wave with almost rail-to-rail swing. With the components shown, frequency of operation is given by the equation:

$$f_{OUT} = V_{CONTROL} \text{ (volts)} \times 10\text{Hz/V}$$

but this is easily changed by varying C1. The circuit operates well up to a few hundred hertz.

**FIGURE 8:** Micropower Voltage Controlled Oscillator

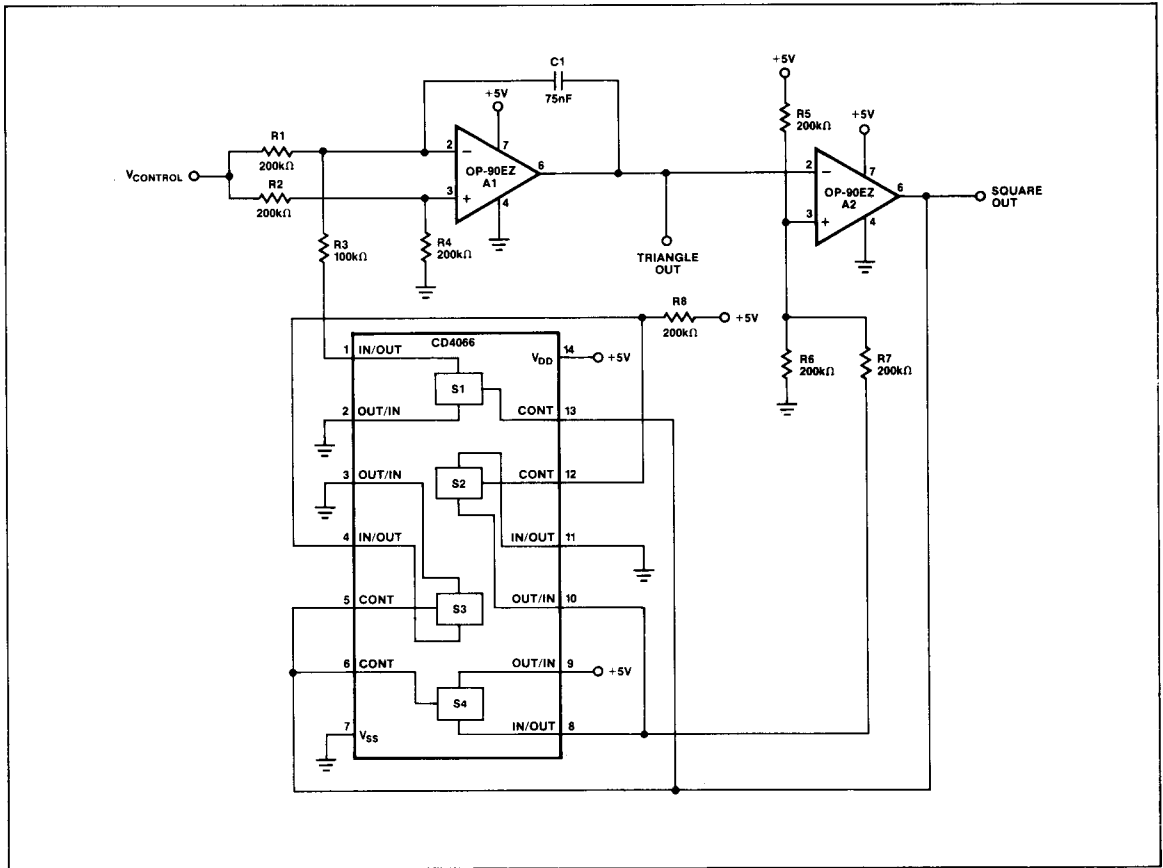

### MICROPOWER SINGLE-SUPPLY INSTRUMENTATION AMPLIFIER

The simple instrumentation amplifier of Figure 9 provides over 110dB of common-mode rejection and draws only  $15\mu\text{A}$  of supply current. Feedback is to the trim pins rather than to the inverting input. This enables a single amplifier to provide differential to single-ended conversion with excellent common-mode rejection. Distortion of the instrumentation amplifier is that of a differential pair, so the circuit is restricted to high gain applications. Nonlinearity is less than 0.1% for gains of 500 to 1000 over a 2.5V output range. Resistors R3 and R4 set the voltage gain and, with the values shown, yield a gain of 1000. Gain tempco of the instrumentation amplifier is only  $50\text{ppm}/^\circ\text{C}$ . Offset voltage is under  $150\mu\text{V}$  with drift below  $2\mu\text{V}/^\circ\text{C}$ . The OP-90's input and output voltage ranges include the negative rail which allows the instrumentation amplifier to provide true "zero-in, zero-out" operation.

**FIGURE 9:** Micropower Single-Supply Instrumentation Amplifier

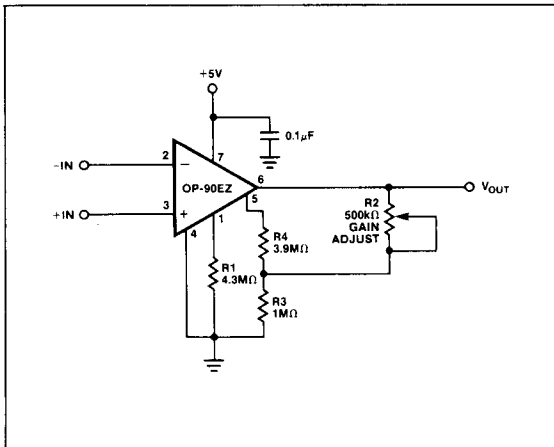

### SINGLE-SUPPLY CURRENT MONITOR

Current monitoring essentially consists of amplifying the voltage drop across a resistor placed in series with the current to be measured. The difficulty is that only small voltage drops can be tolerated and with low precision op amps this greatly limits the overall resolution. The single-supply current monitor of Figure 10 has a resolution of  $10\mu\text{A}$  and is capable of monitoring 30mA of current. This range can be adjusted by changing the current sense resistor R1. When measuring total system current, it may be necessary to include the supply current of the current monitor, which bypasses the current sense resistor, in the final result. This current can be measured and calibrated (together with the residual offset) by adjustment of the offset trim potentiometer, R2. This produces a deliberate offset that is temperature dependent. However, the supply current of the OP-90 is also proportional to temperature and the two effects tend to track. Current in R4 and R5, which also bypasses R1, can be accounted for by a gain trim.

**FIGURE 10:** Single-Supply Current Monitor

