



## L1138

Preliminary

CMOS IC

### HIGH OUTPUT CURRENT CMOS VOLTAGE REGULATOR WITH HIGH RIPPLE-REJECTION AND LOW DROPOUT

#### DESCRIPTION

The UTC **L1138** is a positive LDO voltage regulator using CMOS technology. It is featured as: low dropout voltage, high output voltage accuracy, and low current consumption.

The internal circuits include a low on-resistance transistor to provide a low dropout voltage and large output current; an overcurrent protector to make sure the load current don't exceed the current capacitance of the output transistor, a thermal shutdown circuit to escape device damage from over-heat, and an ON/OFF circuit to keep the battery life longer.

In applications, the UTC **L1138** can be used in power supply unit for DVD, CD-ROM drives, battery-powered devices, personal communication devices, and NBs.

#### FEATURES

- \* Output voltage's high accuracy:  $\pm 1.0\%$
- \* Low dropout voltage: 120mV typ.  
@3.3V output ,  $I_{OUT}=300mA$
- \* Low current consumption: 80 $\mu A$ (Typ.)160 $\mu A$  max in operation  
0.1 $\mu A$ (Typ.)1.0 $\mu A$  max in shutdown mode
- \* High current capability: 800mA output  
@ $V_{IN} \geq V_{OUT(S)} + 1.0V$
- \* With ON/OFF circuit: Ensures long battery life.
- \* High ripple rejection 70dB typ@1.0kHz
- \* With over current protector
- \* With thermal shutdown circuit

#### ORDERING INFORMATION

Ordering Number	Package	Packing
L1138G-xx-AB5-R	SOT-89-5	Tape Reel
L1138G-xx-AF5-R	SOT-25	Tape Reel
L1138G-xx-S08-R	SOP-8	Tape Reel

xx: Output Voltage, refer to Marking Information.

<p>L1138G-xx-AB5-R</p>	<p>(1) Packing Type (1) R: Tape Reel</p> <p>(2) Package Type (2) AB5: SOT-89-5, AF5: SOT-25, S08: SOP-8</p> <p>(3) Output Voltage Code (3) xx: Refer to Marking Information</p> <p>(4) Green Package (4) G: Halogen Free and Lead Free</p>
------------------------	--

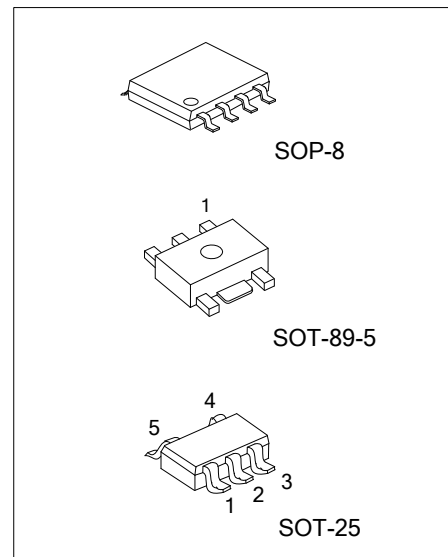

### MARKING INFORMATION

PACKAGE	VOLTAGE CODE	MARKING
SOT-89-5	12: 1.2V 25: 2.5V 28: 2.8V 33: 3.3V 35: 3.5V 36: 3.6V 45: 4.5V 50: 5.0V	
SOT-25		
SOP-8		

### PIN CONFIGURATION

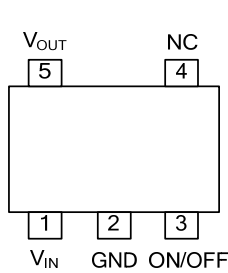

SOT-25

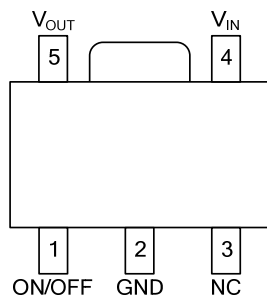

SOT-89-5

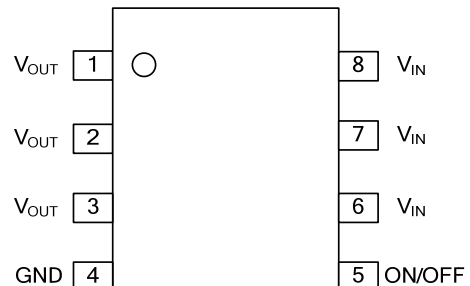

SOP-8

### PIN DESCRIPTION

#### FOR /SOT-89-5 Package

PIN NO.		PIN NAME	DESCRIPTION
SOT-25	SOT-89-5		
1	4	$V_{IN}$	Input voltage Pin
2	2	GND	Ground Pin
3	1	ON/OFF	Shutdown Pin
4	3	NC	No Connection, NC pin is electrically open and can be connected $V_{IN}$ and GND
5	5	$V_{OUT}$	Output voltage Pin

#### FOR SOP-8 Package

PIN NO.	PIN NAME	DESCRIPTION
1,2,3	$V_{OUT}$	Output voltage Pin (Note 1)
4	GND	Ground Pin
5	ON/OFF	Shutdown Pin
6,7,8	$V_{IN}$	Input voltage Pin (Note 2)

Notes: 1. Short pins 1, 2, 3  
 2. Short pins 6, 7, 8

■ BLOCK DIAGRAM

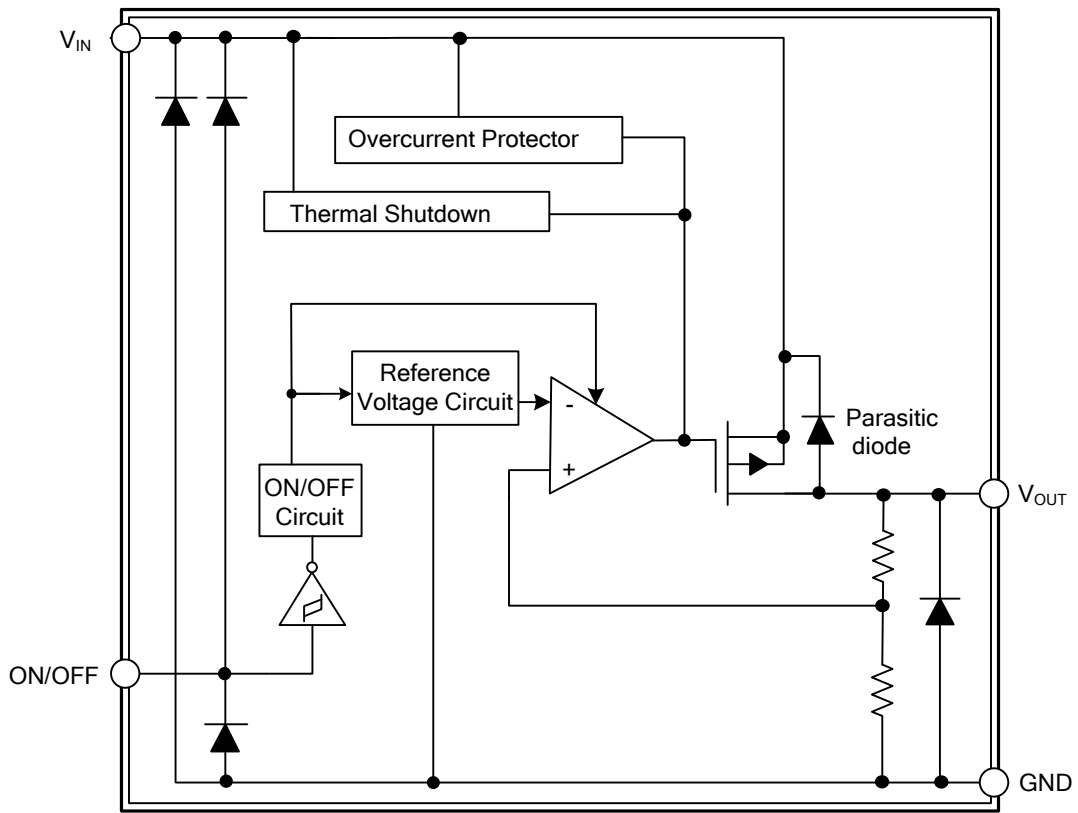

■ ABSOLUTE MAXIMUM RATING ( $T_A = 25^\circ\text{C}$ , unless otherwise specified)

PARAMETER	SYMBOL	RATINGS	UNIT
Input Voltage	$V_{IN}$	7	V
	$V_{ON/OFF}$	$V_{IN}+0.3$	V
Output Voltage	$V_{OUT}$	$V_{IN}+0.3$	V
Power Dissipation	$P_D$	Internally limited	mW
Operating Temperature	$T_{OPR}$	-40~+85	$^\circ\text{C}$
Storage Temperature	$T_{STG}$	-40~+125	$^\circ\text{C}$

Note: Absolute maximum ratings are those values beyond which the device could be permanently damaged. Absolute maximum ratings are stress ratings only and functional device operation is not implied.

■ ELECTRICAL CHARACTERISTICS ( $T_A = 25^\circ\text{C}$ ,  $V_{IN}=V_{OUT}+1\text{V}$ , unless otherwise specified)

Parameter	SYMBOL	TEST CONDITIONS	MIN	TYP	MAX	UNIT
Input Voltage	$V_{IN}$				6.5	V
Output Voltage (Note 1)	$V_{OUT(E)}$	$V_{IN} = V_{OUT(S)} + 1.0\text{V}$ , $I_{OUT} = 100\text{mA}$	-1%		+1%	V
Line Regulation	$\frac{\Delta V_{OUT1}}{\Delta V_{IN} \times V_{OUT}}$	$V_{OUT(S)} + 0.5\text{V} \leq V_{IN} \leq 6.5\text{V}$ , $I_{OUT} = 100\text{mA}$		0.05	0.3	%/V
Load Regulation	$\Delta V_{OUT2}$	$V_{IN} = V_{OUT(S)} + 1.0\text{V}$ , $1.0\text{mA} \leq I_{OUT} \leq 300\text{mA}$		30	100	mV
Output Current (Note 2)	$I_{OUT}$	$V_{IN} \leq V_{OUT(S)} + 1.0\text{V}$	800			mA
Current Consumption During	Operation	$I_{SS1}$ $V_{IN} = V_{OUT(S)} + 1.0\text{V}$ , ON/OFF pin = ON, no load		80	160	$\mu\text{A}$
	Shutdown	$I_{SS2}$ $V_{IN} = V_{OUT(S)} + 1.0\text{V}$ , ON/OFF pin = OFF, no load		0.1	1.0	$\mu\text{A}$
Short-Circuit Current	$I_{SHORT}$	$V_{IN} = V_{OUT(S)} + 1.0\text{V}$ , ON/OFF pin = ON, $V_{OUT} = 0\text{V}$		350		mA
Dropout Voltage (Note 3)	$V_D$	$I_{OUT} = 300\text{mA}$	$V_{OUT(S)} = 1.2\text{V}$	0.8	1.0	V
			$V_{OUT(S)} = 2.5\text{V}$	0.15	0.22	
			$V_{OUT(S)} = 2.8\text{V}$	0.15	0.22	
			$3.3\text{V} \leq V_{OUT(S)} \leq 5.5\text{V}$	0.12	0.18	
Temperature Coefficient of Output Voltage	$T_C V_O$	$V_{IN} = V_{OUT(S)} + 1.0\text{V}$ , $I_{OUT} = 10\text{mA}$ , $-40^\circ\text{C} \leq T_A \leq 85^\circ\text{C}$		$\pm 150$		ppm/ $^\circ\text{C}$
Power Supply Rejection	PSRR	$V_{IN} = V_{OUT(S)} + 1.0\text{V}$ $f = 1.0\text{kHz}$ , $I_{OUT} = 100\text{mA}$ $\Delta V_{rip} = 0.5\text{V}_{rms}$	$1.2\text{V} \leq V_{OUT(S)} \leq 3.0\text{V}$	70		dB
			$3.1\text{V} \leq V_{OUT(S)} \leq 5.5\text{V}$	65		
Shutdown Pin Input Voltage	High	$V_{SH}$	$V_{IN} = V_{OUT(S)} + 1.0\text{V}$	1.5		V
Shutdown Pin Input Current	Low	$V_{SL}$	$V_{IN} = V_{OUT(S)} + 1.0\text{V}$		0.3	V
Thermal Shutdown Temperature	Detection	$T_{SD}$	Junction temperature		150	$^\circ\text{C}$
	Release	$T_{SR}$	Junction temperature		120	$^\circ\text{C}$

Notes: 1.  $V_{OUT(S)}$ : Specified output voltage.

$V_{OUT(E)}$ : Actual output voltage at the fixed load

2. When fixing ( $I_{OUT} = 100\text{mA}$ ) and inputting  $V_{OUT(S)} + 1.0\text{V}$

3. This output current means the one at which the output voltage becomes 98% of  $V_{OUT(E)}$  after gradually increasing the output current.

4. The dropout voltage is defined as  $V_{IN} - V_{OUT}$ , which is measured when  $V_{OUT}$  is  $V_{OUT(normal)} \times 98\%$

■ OPERATION

1. Basic operation

The reference voltage ( $V_{REF}$ ) and  $V_{FB}$ (the output voltage resistance-divided by feedback resistors  $R_S$  and  $R_F$ ) are the input for the error amplifier.

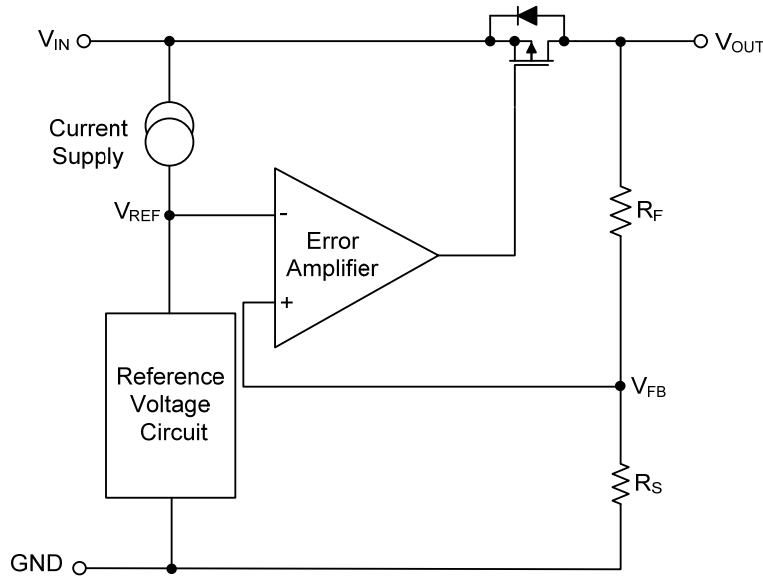

2. Output transistor

A low on-resistance P-channel MOSFET is used as the output transistor. Inverse current flowing from  $V_{OUT}$  pin through a parasitic diode to  $V_{IN}$  pin can damage the regulator, so be sure that  $V_{OUT}$  does not exceed  $V_{IN} + 0.3V$ .

3. Shutdown pin (ON/OFF pin)

The shutdown pin can start and stop the regulator. The shutdown mode set by this pin can stop the operation of all internal circuits. The structure of the ON/OFF pin is shown in Fig. 1. When the ON/OFF pin is not used, connect it to the GND pin if the logic type is "A" and to the  $V_{IN}$  pin if it is "B".

Logic Type	ON/OFF Pin	Internal Circuits	$V_{OUT}$ Pin Voltage	Current Consumption
A	"L": Power on	Operating	Set value	$I_{SS1}$
A	"H": Power off	Stopped	GND level	$I_{SS2}$
B	"L": Power off	Stopped	GND level	$I_{SS2}$
B	"H": Power on	Operating	Set value	$I_{SS1}$

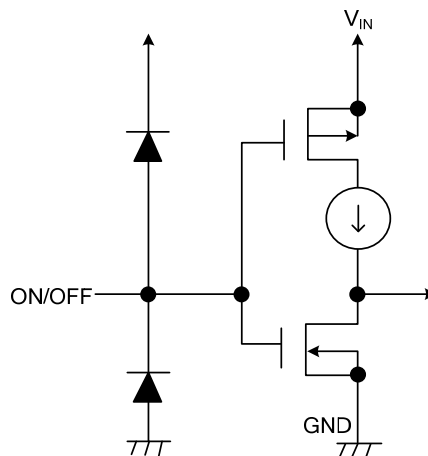
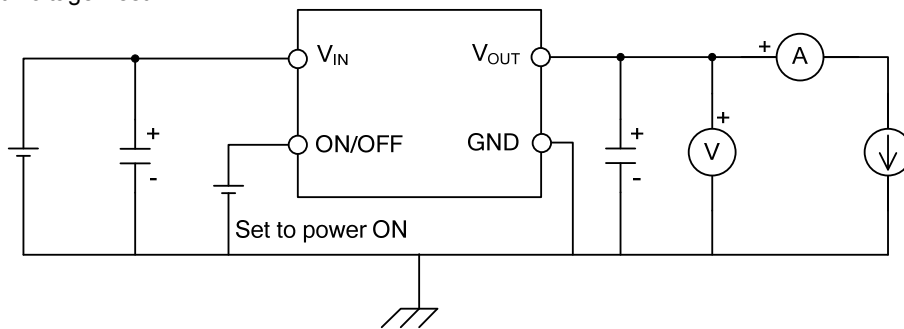

Fig. 1

■ TEST CIRCUITS

1. Output Voltage Test



2. Current Consumption Test

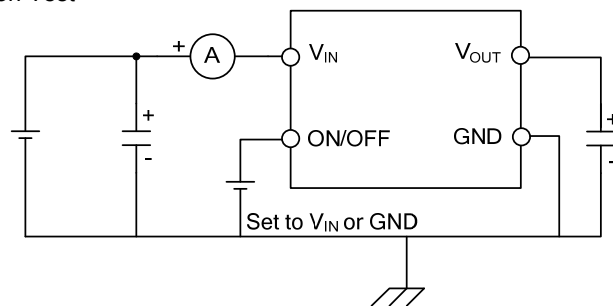

3. Output Current Test

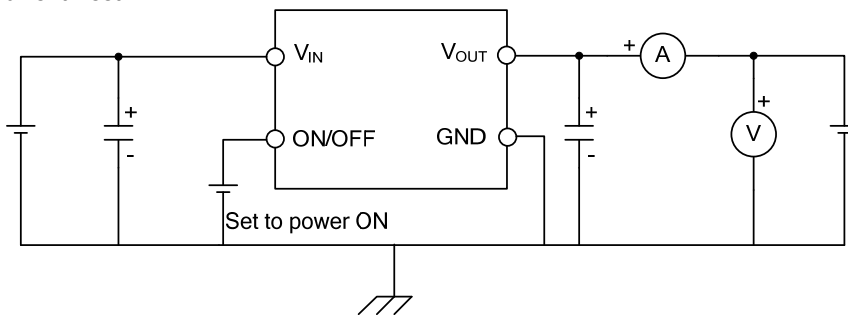

4. Shutdown Pin Input Voltage / Current Test

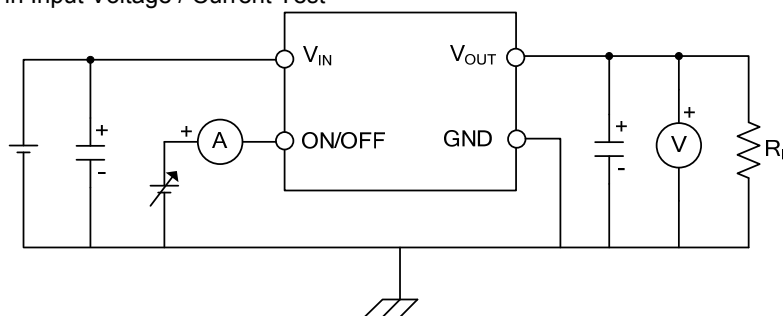

5. Power Supply Rejection Test

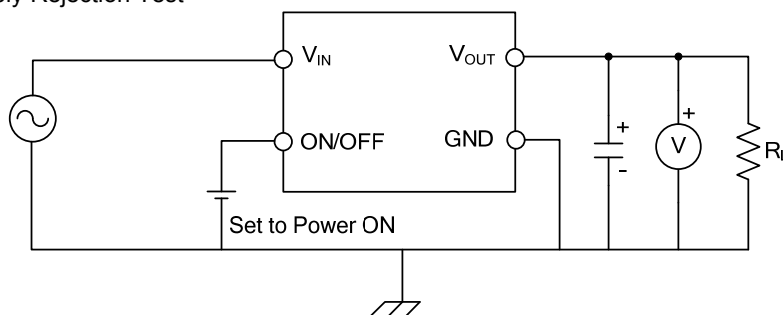

## ■ TYPICAL APPLICATION CIRCUIT

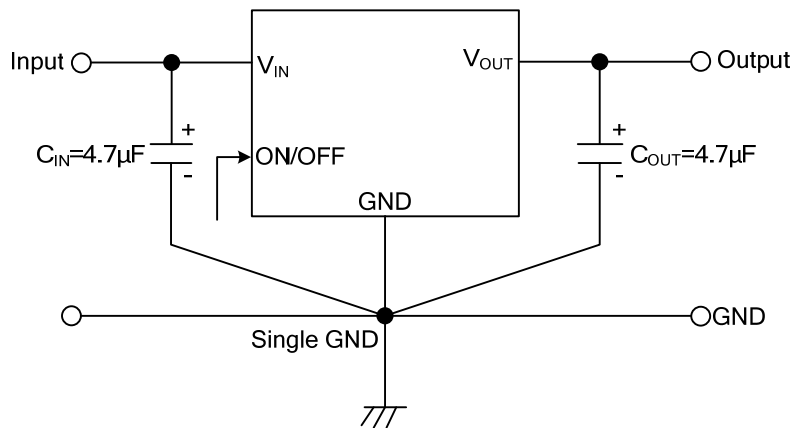

UTC assumes no responsibility for equipment failures that result from using products at values that exceed, even momentarily, rated values (such as maximum ratings, operating condition ranges, or other parameters) listed in products specifications of any and all UTC products described or contained herein. UTC products are not designed for use in life support appliances, devices or systems where malfunction of these products can be reasonably expected to result in personal injury. Reproduction in whole or in part is prohibited without the prior written consent of the copyright owner. The information presented in this document does not form part of any quotation or contract, is believed to be accurate and reliable and may be changed without notice.