

GD54/74HC377, GD54/74HCT377

OCTAL D-TYPE FLIP-FLOPS WITH COMMON CLOCK & ENABLE

General Description

These devices are identical in pinout to the 54 74LS377. They contain eight master/slave D-type flip-flops with a common clock and enable. Information at the data inputs meeting the setup and hold time requirements is transferred to the outputs on the rising edge of the clock pulse if the enable input is low. When the clock input is at either the high or low level, the data input signal has no effect at the output. The circuits are designed to prevent false clocking by transitions at the enable input. The HC:HCT 377 are similar to the HC/HCT 273, but feature a common enable instead of a common clear. These devices are characterized for operation over wide temperature ranges to meet industry and military specifications.

Pin Configuration

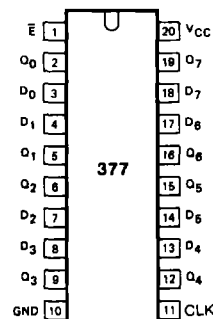

Suffix-Blank : Plastic Dual In Line Package
 Suffix-J : Ceramic Dual In Line Package
 Suffix-D : Small Outline Package

Features

- Low Power consumption characteristic of CMOS devices
- Output drive capability: 10 LS TTL Loads Min.
- Operating speed superior to LS TTL
- Wide operating voltage range: for HC 2 to 6 volts
for HCT 4.5 to 5.5 volts
- Low input current: 1 μ A Max.
- Low quiescent current: 80 μ A Max. (74HC)
- High noise immunity characteristic of CMOS
- Diode protection on all inputs

Function Table

OPERATING MODES	INPUTS			OUTPUTS
	CLK	\bar{E}	D_n	Q_n
load "1"	↑	l	h	H
load "0"	↑	l	l	L
hold (do nothing)	↑	h	X	no change
	X	H	X	no change

H = HIGH voltage level
 h = HIGH voltage level one set-up time prior to the LOW-to-HIGH CLK transition
 L = LOW voltage level
 l = LOW voltage level one set-up time prior to the LOW-to-HIGH CLK transition
 ↑ = LOW-to-HIGH transition
 X = don't care

Absolute Maximum Ratings

SYMBOL	PARAMETER	CONDITIONS	MIN.	MAX	UNIT
V_{CC}	DC Supply voltage		-0.5	+7	V
I_{IK}, I_{OK}	DC input or output diode current	for $V_I < -0.5$ or $V_I > V_{CC} + 0.5V$		20	mA
I_O	DC output source or sink current	for $-0.5V < V_O < V_{CC} + 0.5V$		25	mA
I_{CC}	DC V_{CC} or GND current			50	mA
T_{stg}	Storage temperature range		-65	150	°C
P_D	Power dissipation per package	above +70°C derate linearly with 8mW/K		500	mW
T_L	Lead temperature	At distance 1/16 ± 1/32 in from case for 60 sec(CERAMIC) 10 sec(PLASTIC)		300 260	°C

Recommended Operating Conditions

CHARACTERISTIC	LIMITS		UNITS	
	MIN	MAX		
Supply-Voltage Range V_{CC}	GD54/74HC Types GD54/74HCT Types	2 4.5	6 5.5	V
DC Input or Output Voltage V_I, V_O		0	V_{CC}	V
Operating Temperature T_A	GD74 Types GD54 Types	-40 -55	+85 +125	°C
Input Rise and Fall times t_r, t_f	GD54/74HC Types at 2V at 4.5V at 6V GD54/74HCT Types at 4.5V		1000 500 400 500	ns

Logic Diagram

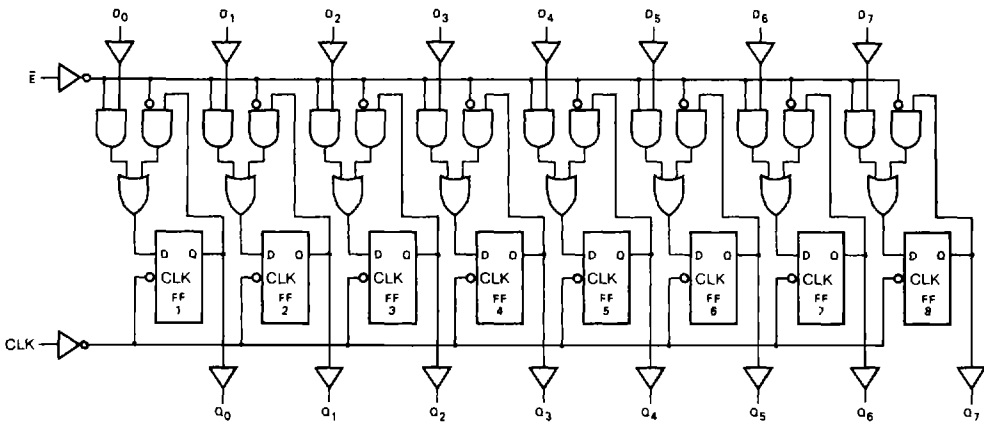

Fig. 1 Logic diagram

DC Electrical Characteristics for HC

SYMBOL	PARAMETER	TEST CONDITION	V _{CC} (V)	T _A =25°C			GD54HC377		GD74HC377		UNIT	
				MIN.	TYP.	MAX.	MIN	MAX	MIN	MAX		
V _{IH}	HIGH level input Voltage		2.0	1.5			1.5		1.5		V	
			4.5	3.15			3.15		3.15			
			6.0	4.2			4.2		4.2			
V _{IL}	LOW level input voltage		2.0			0.3		0.3		0.3	V	
			4.5			0.9		0.9		0.9		
			6.0			1.2		1.2		1.2		
V _{OH}	HIGH level output voltage	V _{IN} =V _{IH}	I _{OH} =-20μA	2.0	1.9	2.0		1.9		1.9	V	
				4.5	4.4	4.5		4.4		4.4		
		or V _{IL}	I _{OH} =-4mA	4.5	3.98	4.3		3.84		3.7		
				6.0	5.48	5.2		5.34		5.2		
		or V _{IL}	I _{OH} =-5.2mA	4.5								
				6.0								
V _{OL}	LOW level output voltage	V _{IN} =V _{IH}	I _{OL} =20μA	2.0			0.1		0.1		V	
				4.5			0.1		0.1			0.1
		or V _{IL}	I _{OL} =4mA	4.5		0.17	0.26		0.33			0.4
				6.0		0.15	0.26		0.33			0.4
		or V _{IL}	I _{OL} =5.2mA	4.5								
				6.0								
I _{IN}	Input leakage Current	V _{IN} =V _{CC} or GND	6.0			0.1		1.0		1.0	μA	
I _{CC}	Quiescent Supply Current	V _{IN} =V _{CC} or GND I _{out} =0μA	6.0			2		80		160	μA	

DC Electrical Characteristics for HCT

SYMBOL	PARAMETER	TEST CONDITION	V _{CC} (V)	T _A =25°C			GD74HCT377		GD54HCT377		UNIT	
				MIN	TYP.	MAX	MIN	MAX	MIN	MAX		
V _{IH}	HIGH level input Voltage		4.5								V	
			to	2.0			2.0		2.0			
			5.5									
V _{IL}	LOW level input voltage		4.5								V	
			to			0.8		0.8		0.8		
			5.5									
V _{OH}	HIGH level output voltage	V _{IN} =V _{IH}	I _{OH} =-20μA	4.5	4.4	4.5		4.4		4.4	V	
				4.5	3.98	4.3		3.84		3.7		
		or V _{IL}	I _{OH} =-4mA	4.5								
				6.0								
		or V _{IL}	I _{OH} =-5.2mA	4.5								
				6.0								
V _{OL}	LOW level output voltage	V _{IN} =V _{IH}	I _{OL} =20μA	4.5			0.1		0.1		V	
				4.5								
		or V _{IL}	I _{OL} =4mA	4.5		0.17	0.26		0.33			0.4
				6.0								
		or V _{IL}	I _{OL} =5.2mA	4.5								
				6.0								
I _{IN}	Input leakage Current	V _{IN} =V _{CC} or GND	5.5			0.1		1.0		1.0	μA	
I _{CC}	Quiescent Supply Current	V _{IN} =V _{CC} or GND I _{out} =0μA	5.5			8		80		160	μA	

Timing Requirements for HC: $t_r=t_f=6\text{ns}$ $C_L=50\text{ pF}$

SYMBOL	PARAMETER		V _{CC} (V)	T _A =25°C			GD74HC377		GD54HC377		UNIT
				MIN.	TYP.	MAX.	MIN.	MAX.	MIN.	MAX.	
t _w	Pulse width	CLK high	2.0	80	30		100		120		ns
			4.5	16	10		20		25		
			6.0	14	8		18		22		
t _{su}	Setup time	Data before CLK†	2.0	60	30		100		120		ns
			4.5	12	10		20		25		
			6.0	10	8		18		22		
t _h	Hold time	Data after CLK†	2.0	3	0		3		3		ns
			4.5	3	0		3		3		
			6.0	3	0		3		3		

AC Characteristics for HC: $t_r=t_f=6\text{ns}$ $C_L=50\text{ pF}$

SYMBOL	PARAMETER		V _{CC} (V)	T _A =25°C			GD74HC377		GD54HC377		UNIT
				MIN.	TYP.	MAX.	MIN.	MAX.	MIN.	MAX.	
f _{max}	Maximum Clock Pulse Frequency		2.0	6	20		5		4		MHz
			4.5	30	65		25		20		
			6.0	35	75		30		25		
t _{PLH} ' t _{PHL}	Propagation Delay Time CLK to Qn		2.0		38	110		140		160	ns
			4.5		14	24		30		34	
			6.0		12	20		25		30	
t _{TLH} ' t _{THL}	Output Transition Time		2.0		25	70		85		100	ns
			4.5		8	15		18		22	
			6.0		7	13		16		19	

Timing Requirements for HCT: $t_r=t_f=6\text{ns}$ $C_L=50\text{ pF}$

SYMBOL	PARAMETER		V_{CC} (V)	$T_A=25^\circ\text{C}$			GD74HCT377		GD54HCT377		UNIT
				MIN.	TYP	MAX.	MIN.	MAX.	MIN.	MAX.	
t_w	Pulse Width	CLK High or Low	4.5	16	10		20		25		ns
t_{su}	Setup time	Data before CLK↑	4.5	12	10		20		25		ns
t_h	Hold time	Data after CLK↑	4.5	3	0		3		3		ns

AC Characteristics for HCT: $t_r=t_f=6\text{ns}$ $C_L=50\text{ pF}$

SYMBOL	PARAMETER		V_{CC} (V)	$T_A=25^\circ\text{C}$			GD74HCT377		GD54HCT377		UNIT
				MIN.	TYP	MAX.	MIN.	MAX.	MIN.	MAX.	
f_{max}	Maximum Clock Pulse Frequency		4.5	27	54		22		18		MHz
t_{PLH} t_{PHL}	Propagation Delay Time CLK to Q_n		4.5		16	26		32		36	ns
t_{TLH} t_{THL}	Output Transition Time		4.5		8	15		18		22	ns

AC Waveforms

