

CD74FCT646T, CD74FCT648T, CD74FCT651T, CD74FCT652T, CD74FCT2646T, CD74FCT2652T

December 1996

Fast CMOS Octal Registered Transceivers

Features

- Advanced 0.8 micron CMOS Technology
- These Devices are Pin Compatible with Bipolar FAST™ Series at a Higher Speed, Lower Power Consumption
- 25Ω Series Resistor on All Outputs (FCT2XXX Only)
- TTL Input and Output Levels
- Low Ground Bounce Outputs
- Extremely Low Static Power
- Hysteresis on All Inputs

Description

These devices are designed with a bus transceiver with three-state D-type flip-flops and control circuitry arranged for multiplexed transmission of data directly from the data bus or from the internal storage registers. The CD74FCT651T, CD74FCT652T and CD74FCT2652T utilize GAB and $\overline{\text{GBA}}$ signals to control the transceiver functions. The CD74FCT646T, CD74FCT2646T and CD74FCT648T utilize the enable control ($\overline{\text{G}}$) and direction pins (DIR) to control the transceiver functions. SAB and SBA control pins are used to select either real-time or stored data transfer. The circuitry used for select control will eliminate the typical decoding glitch that occurs in a multiplexer during the transition between real-time and stored data. A low input level selects real-time data and a high selects stored data.

The CD74FCT646T is a non-inverting option of the CD74FCT648T. The CD74FCT652T is a non-inverting option of the CD74FCT651T.

The CD74FCT2646T and CD74FCT2652T devices have a built-in 25Ω series resistor on all outputs to reduce noise due to reflections, thus eliminating the need for an external terminating resistor.

Ordering Information

PART NUMBER	TEMP. RANGE (°C)	PACKAGE	PKG. NO.
CD74FCT646ATM	-40 to 85	24 Ld SOIC	M24.3-P
CD74FCT646ATQM	-40 to 85	24 Ld QSOP	M24.15-P
CD74FCT646CTM	-40 to 85	24 Ld SOIC	M24.3-P
CD74FCT646CTQM	-40 to 85	24 Ld QSOP	M24.15-P
CD74FCT646DTM	-40 to 85	24 Ld SOIC	M24.3-P
CD74FCT646DTQM	-40 to 85	24 Ld QSOP	M24.15-P
CD74FCT646TM	-40 to 85	24 Ld SOIC	M24.3-P
CD74FCT646TQM	-40 to 85	24 Ld QSOP	M24.15-P
CD74FCT648ATM	-40 to 85	24 Ld SOIC	M24.3-P
CD74FCT648ATQM	-40 to 85	24 Ld QSOP	M24.15-P
CD74FCT648CTM	-40 to 85	24 Ld SOIC	M24.3-P
CD74FCT648CTQM	-40 to 85	24 Ld QSOP	M24.15-P
CD74FCT648TM	-40 to 85	24 Ld SOIC	M24.3-P
CD74FCT648TQM	-40 to 85	24 Ld QSOP	M24.15-P
CD74FCT651ATM	-40 to 85	24 Ld SOIC	M24.3-P
CD74FCT651ATQM	-40 to 85	24 Ld QSOP	M24.15-P
CD74FCT651CTM	-40 to 85	24 Ld SOIC	M24.3-P
CD74FCT651CTQM	-40 to 85	24 Ld QSOP	M24.15-P
CD74FCT651TM	-40 to 85	24 Ld SOIC	M24.3-P
CD74FCT651TQM	-40 to 85	24 Ld QSOP	M24.15-P
CD74FCT652ATM	-40 to 85	24 Ld SOIC	M24.3-P
CD74FCT652ATQM	-40 to 85	24 Ld QSOP	M24.15-P
CD74FCT652CTM	-40 to 85	24 Ld SOIC	M24.3-P
CD74FCT652CTQM	-40 to 85	24 Ld QSOP	M24.15-P
CD74FCT652DTM	-40 to 85	24 Ld SOIC	M24.3-P
CD74FCT652DTQM	-40 to 85	24 Ld QSOP	M24.15-P
CD74FCT652TM	-40 to 85	24 Ld SOIC	M24.3-P
CD74FCT652TQM	-40 to 85	24 Ld QSOP	M24.15-P
CD74FCT2646ATM	-40 to 85	24 Ld SOIC	M24.3-P
CD74FCT2646ATQM	-40 to 85	24 Ld QSOP	M24.15-P
CD74FCT2646TM	-40 to 85	24 Ld SOIC	M24.3-P
CD74FCT2646TQM	-40 to 85	24 Ld QSOP	M24.15-P
CD74FCT2652ATM	-40 to 85	24 Ld SOIC	M24.3-P
CD74FCT2652ATQM	-40 to 85	24 Ld QSOP	M24.15-P
CD74FCT2652CTM	-40 to 85	24 Ld SOIC	M24.3-P
CD74FCT2652CTQM	-40 to 85	24 Ld QSOP	M24.15-P
CD74FCT2652TM	-40 to 85	24 Ld SOIC	M24.3-P
CD74FCT2652TQM	-40 to 85	24 Ld QSOP	M24.15-P

NOTE: QSOP is commonly known as SSOP.

When ordering, use the entire part number. Add the suffix 96 to obtain the variant in the tape and reel.

Pinouts

CD74FCT646T, CD74FCT648T, CD74FCT2646T
(QSOP, SOIC)
TOP VIEW

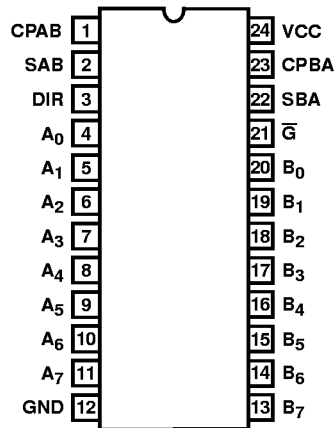

CD74FCT651T, CD74FCT652T, CD74FCT2652T
(QSOP, SOIC)
TOP VIEW

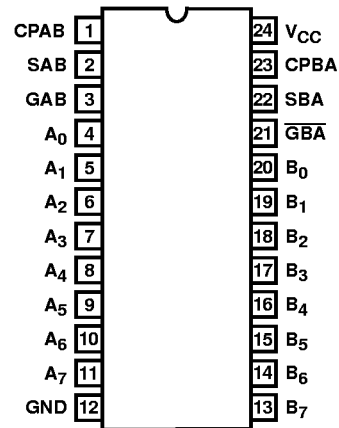

Functional Block Diagram

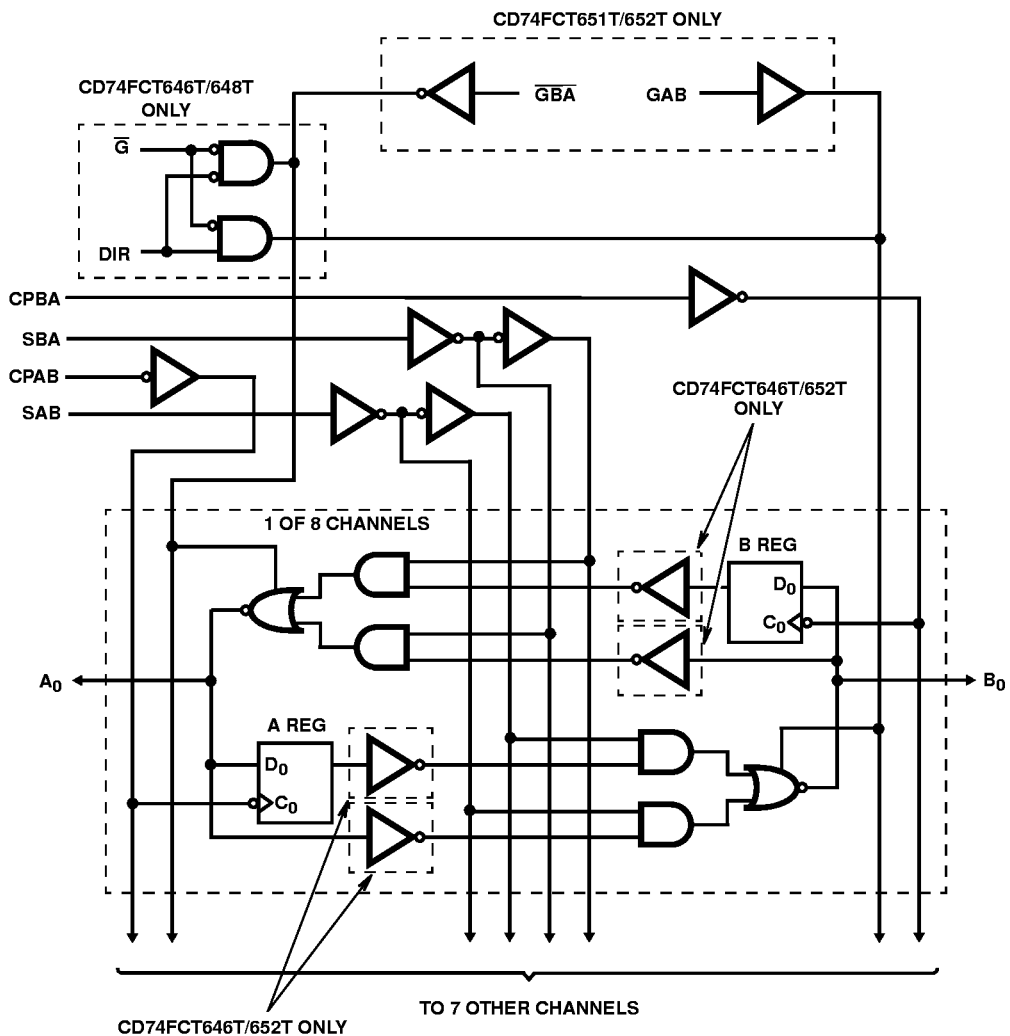

CD74FCT646T, CD74FCT648T, CD74FCT651T, CD74FCT652T, CD74FCT2646T, CD74FCT2652T

CD74FCT646T, CD74FCT2646T, CD74FCT648T TRUTH TABLE

CD74FCT646T, CD74FCT2646T	CD74FCT648T	INPUTS						(NOTE 2) DATA I/O	
		FUNCTION/OPERATION	FUNCTION/OPERATION	\overline{G}	DIR	CPAB	CPBA	SAB	SBA
Isolation	Isolation	H	X	H or L	H or L	X	X	Input	Input
Store A and B Data	Store A and B Data	H	X	↑	↑	X	X	Input	Input
Real Time B Data to A Bus	Real Time \overline{B} Data to A Bus	L	L	X	X	X	L	Output	Input
Stored B Data to A Bus	Stored \overline{B} Data to A Bus	L	L	X	H or L	X	H	Output	Input
Real Time A Data to B Bus	Real Time \overline{A} Data to B Bus	L	H	X	X	L	X	Input	Output
Stored A Data to B Bus	Stored \overline{A} Data to B Bus	L	H	H or L	X	H	X	Input	Output

CD74FCT651T, CD74FCT652T, CD74FCT2652T TRUTH TABLE

CD74FCT651T	CD74FCT652T, CD74FCT2652T	INPUTS						(NOTE 2) DATA I/O	
		FUNCTION/OPERATION	FUNCTION/OPERATION	GAB	\overline{GBA}	CPAB	CPBA	SAB	SBA
Isolation	Isolation	L	H	H or L	H or L	X	X	Input	Input
Store A and B Data	Store A and B Data	L	H	↑	↑	X	X	Input	Input
Store A, Hold B	Store A, Hold B	X	H	↑	H or L	X	X	Input	Unspecified (Note 1)
Store A in Both Registers (Note 3)	Store A in Both Registers	H	H	↑	↑	X (Note 2)	X	Input	Output
Hold A, Store B	Hold A, Store B	L	X	H or L	↑	X	X	Unspecified (Note 1)	Input
Store B in Both Registers (Note 4)	Store B in Both Registers	L	L	↑	↑	X	X (Note 2)	Output	Input
Real Time \overline{B} Data to A Bus	Real Time B Data to A Bus	L	L	X	X	X	L	Output	Input
Stored \overline{B} Data to A Bus	Stored B Data to A Bus	L	L	X	H or L	X	H	Output	Input
Real Time \overline{A} Data to B Bus	Real Time A Data to B Bus	H	H	X	X	L	X	Input	Output
Stored \overline{A} Data to B Bus	Stored A Data to B Bus	H	H	H or L	X	H	X	Input	Output
Stored \overline{A} Data to B Bus and Stored \overline{B} Data to A Bus	Stored A Data to B Bus and Stored B Data to A Bus	H	L	H or L	H or L	H	H	Output	Output

NOTES:

- The data output functions may be enabled or disabled by various signals at the GAB or \overline{GBA} inputs. Data input functions are always enabled, i.e., data at the bus pins will be stored on every low-to-high transition on the clock inputs.
- Select control = L: clocks can occur simultaneously.
Select control = H: clocks must be staggered in order to load both registers.
H = High Voltage Level; L = Low Voltage Level; X = Don't Care; ↑ = LOW-to-HIGH transition
- \overline{A} in B Register.
- \overline{B} in A Register.

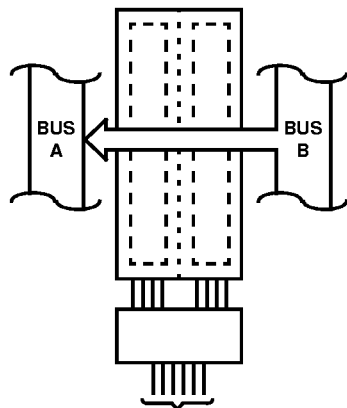

646T/648T/2646T	DIR	\bar{G}	CPAB	CPBA	SAB	SBA
	L	L	X	X	X	L
651T/652T/2652T	GAB	$\bar{G}\bar{B}\bar{A}$	CPAB	CPBA	SAB	SBA
	L	L	X	X	X	L

FIGURE 1. REAL-TIME TRANSFER BUS B TO A

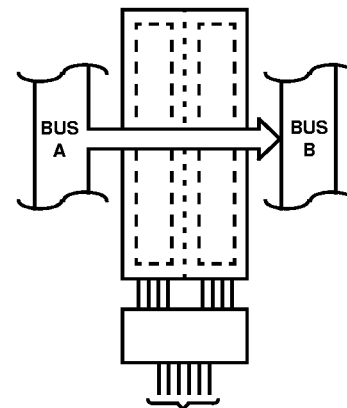

646T/648T/2646T	DIR	\bar{G}	CPAB	CPBA	SAB	SBA
	H	L	X	X	L	X
651T/652T/2652T	GAB	$\bar{G}\bar{B}\bar{A}$	CPAB	CPBA	SAB	SBA
	H	H	X	X	L	X

FIGURE 2. REAL-TIME TRANSFER BUS A TO B

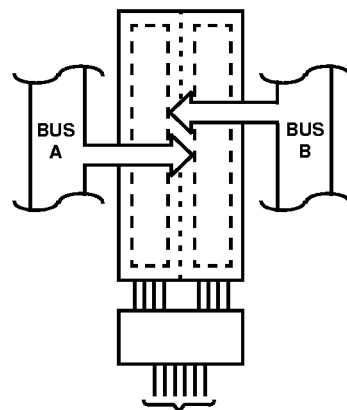

646T/648T/2646T	DIR	\bar{G}	CPAB	CPBA	SAB	SBA
	H	L	↑	X	X	X
	L	L	X	↑	X	X
651T/652T/2652T	GAB	$\bar{G}\bar{B}\bar{A}$	CPAB	CPBA	SAB	SBA
	X	H	↑	X	X	X
	L	X	X	↑	X	X

FIGURE 3. STORAGE FROM A AND/OR B

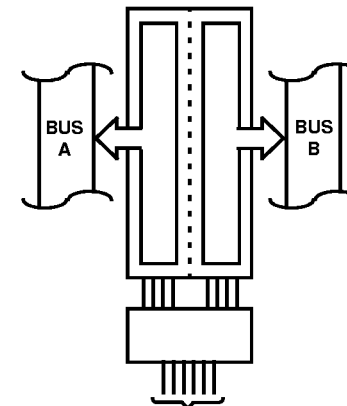

646T/648T/2646T (NOTE 5)	DIR	\bar{G}	CPAB	CPBA	SAB	SBA
	L	L	X	H or L	X	H
651T/652T/2652T	GAB	$\bar{G}\bar{B}\bar{A}$	CPAB	CPBA	SAB	SBA
	H	L	H or L	H or L	H	H

FIGURE 4. TRANSFER STORES DATA TO A AND/OR B

NOTE:

- The CD74FCT646T and CD74FCT2646T cannot transfer data to A bus and B bus simultaneously.

Pin Descriptions

PIN NAME	DESCRIPTION
A ₀ -A ₇	Data Register A Inputs Data Register B Outputs
B ₀ -B ₇	Data Register B Inputs Data Register A Outputs
CPAB, CPBA	Clock Pulse Inputs
SAB, SBA	Output Data Source Select Inputs
DIR, \overline{G}	Output Enable Inputs (CD74FCT646T, CD74FCT648T, CD74FCT2646T)
GAB, \overline{GBA}	Output Enable Inputs (CD74FCT651T, CD74FCT652T, CD74FCT2652T)
GND	Ground
V _{CC}	Power

CD74FCT646T, CD74FCT648T, CD74FCT651T, CD74FCT652T, CD74FCT2646T, CD74FCT2652T

Absolute Maximum Ratings

DC Input Voltage -0.5V to 7.0V
 DC Output Current 120mA

Operating Conditions

Operating Temperature Range -40°C to 85°C
 Supply Voltage to Ground Potential
 Inputs and V_{CC} Only -0.5V to 7.0V
 Supply Voltage to Ground Potential
 Outputs and D/O Only -0.5V to 7.0V

Thermal Information

Thermal Resistance (Typical, Note 6) θ_{JA} (°C/W)
 SOIC Package 75
 QSOP Package 100
 Maximum Junction Temperature 150°C
 Maximum Storage Temperature Range -65°C to 150°C
 Maximum Lead Temperature (Soldering 10s) 300°C
 (Lead Tips Only)

CAUTION: Stresses above those listed in "Absolute Maximum Ratings" may cause permanent damage to the device. This is a stress only rating and operation of the device at these or any other conditions above those indicated in the operational sections of this specification is not implied.

NOTE:

6. θ_{JA} is measured with the component mounted on an evaluation PC board in free air.

Electrical Specifications

PARAMETER	SYMBOL	(NOTE 7) TEST CONDITIONS	MIN	(NOTE 8) TYP	MAX	UNITS
DC ELECTRICAL SPECIFICATIONS Over the Operating Range, T _A = -40°C to 85°C, V _{CC} = 5.0V ±5%						
Output HIGH Voltage	V _{OH}	V _{CC} = Min, V _{IN} = V _{IH} or V _{IL}	I _{OH} = -15.0mA	2.4	3.0	- V
Output LOW Voltage	V _{OL}	V _{CC} = Min, V _{IN} = V _{IH} or V _{IL}	I _{OL} = 64mA	-	0.3	0.55 V
Output LOW Voltage	V _{OL}	V _{CC} = Min, V _{IN} = V _{IH} or V _{IL}	I _{OL} = 12mA (25Ω series)	-	0.3	0.55 V
Input HIGH Voltage	V _{IH}	Guaranteed Logic HIGH Level		2.0	-	- V
Input LOW Voltage	V _{IL}	Guaranteed Logic LOW Level		-	-	0.8 V
Input HIGH Current	I _{IH}	V _{CC} = Max	V _{IN} = V _{CC}	-	-	1 μA
Input LOW Current	I _{IL}	V _{CC} = Max	V _{IN} = GND	-	-	-1 μA
High Impedance Output Current	I _{OZH} , I _{OZL}	V _{CC} = Max	V _{OUT} = 2.7V			1 μA
			V _{OUT} = 0.5V			-1 μA
Clamp Diode Voltage	V _{IK}	V _{CC} = Min, I _{IN} = -18mA		-	-0.7	-1.2 V
Short Circuit Current	I _{OS}	V _{CC} = Max (Note 9), V _{OUT} = GND		-60	-120	- mA
Power Down Disable	I _{OFF}	V _{CC} = GND, V _{OUT} = 4.5V		-	-	100 μA
Input Hysteresis	V _H			-	200	- mV
CAPACITANCE T _A = 25°C, f = 1MHz						
Input Capacitance (Note 10)	C _{IN}	V _{IN} = 0V		-	6	10 pF
Output Capacitance (Note 10)	C _{OUT}	V _{OUT} = 0V		-	8	12 pF
POWER SUPPLY SPECIFICATIONS						
Quiescent Power Supply Current	I _{CC}	V _{CC} = Max	V _{IN} = GND or V _{CC}	-	0.1	500 μA
Supply Current per Input at TTL HIGH	ΔI _{CC}	V _{CC} = Max	V _{IN} = 3.4V (Note 11)	-	0.5	2 mA

Electrical Specifications (Continued)

PARAMETER	SYMBOL	(NOTE 7) TEST CONDITIONS	MIN	(NOTE 8) TYP	MAX	UNITS
Supply Current per Input per MHz (Note 12)	I_{CCD}	$V_{CC} = \text{Max}$, Outputs Open \overline{G} or DIR = GND or GAB = $\overline{GBA} = \text{GND}$ One Input Toggling 50% Duty Cycle	-	0.15	0.25	mA/ MHz
Total Power Supply Current (Note 14)	I_C	$V_{CC} = \text{Max}$, Outputs Open $f_{CP} = 10\text{MHz}$, 50% Duty Cycle $\overline{G} = \text{DIR} = \text{GND}$ or GAB = $\overline{GBA} = \text{GND}$ $f_I = 5\text{MHz}$ One Bit Toggling	-	1.5	3.5 (Note 13)	mA
		$V_{CC} = \text{Max}$, Outputs Open $f_{CP} = 10\text{MHz}$, 50% Duty Cycle $\overline{G} = \text{DIR} = \text{GND}$ or GAB = $\overline{GBA} = \text{GND}$ $f_I = 5\text{MHz}$ One Bit Toggling	-	2.0	5.5 (Note 13)	mA
		$V_{CC} = \text{Max}$, Outputs Open $f_{CP} = 10\text{MHz}$, 50% Duty Cycle $\overline{G} = \text{DIR} = \text{GND}$ or GAB = $\overline{GBA} = \text{GND}$ $f_I = 2.5\text{MHz}$, 50% Duty Cycle Eight Bits Toggling	-	3.8	7.3	mA
			-	6.0	16.3	mA

Switching Specifications Over Operating Range

PARAMETER	SYMBOL	(NOTE 15) TEST CONDITIONS	T		AT		(NOTE 18) CT		(NOTE 18, 19) DT		UNIT
			(NOTE 16) MIN	MAX	(NOTE 16) MIN	MAX	(NOTE 16) MIN	MAX	(NOTE 16) MIN	MAX	
CD74FCT646T, CD74FCT2646T, CD74FCT648T											
Propagation Delay Bus to Bus	t_{PLH} , t_{PHL}	$C_L = 50\text{pF}$ $R_L = 500\Omega$	2.0	7.5	2.0	6.3	1.5	5.4	1.5	4.8	ns
Output Enable Time \overline{G} , DIR to Bus	t_{PZH} , t_{PZL}	$C_L = 50\text{pF}$ $R_L = 500\Omega$	2.0	14.0	2.0	9.8	1.5	7.8	1.5	7.3	ns
Output Disable Time \overline{G} , DIR to Bus (Note 17)	t_{PHZ} , t_{PLZ}	$C_L = 50\text{pF}$ $R_L = 500\Omega$	2.0	9.0	2.0	6.3	1.5	6.3	1.5	6.3	ns
Propagation Delay Clock to Bus	t_{PLH} , t_{PHL}	$C_L = 50\text{pF}$ $R_L = 500\Omega$	2.0	9.0	2.0	6.3	1.5	5.7	1.5	5.2	ns
Propagation Delay SBA or SAB to Bus	t_{PLH} , t_{PHL}	$C_L = 50\text{pF}$ $R_L = 500\Omega$	2.0	9.5	2.0	7.7	1.5	6.2	1.5	5.8	ns
Setup Time HIGH or LOW, Bus to Clock	t_{SU}	$C_L = 50\text{pF}$ $R_L = 500\Omega$	4.0	-	2.0	-	2.0	-	2.0	-	ns
Hold Time HIGH or LOW, Bus to Clock	t_H	$C_L = 50\text{pF}$ $R_L = 500\Omega$	2.0	-	1.5	-	1.5	-	1.5	-	ns
Clock Pulse Width HIGH or LOW (Note 17)	t_W	$C_L = 50\text{pF}$ $R_L = 500\Omega$	6.0	-	5.0	-	5.0	-	5.0	-	ns
CD74FCT651T, CD74FCT652T, CD74FCT2652T											
Propagation Delay Bus to Bus	t_{PLH} , t_{PHL}	$C_L = 50\text{pF}$ $R_L = 500\Omega$	2.0	9.0	2.0	6.3	1.5	5.4	1.5	4.8	ns
Output Enable Time \overline{GBA} , GAB to Bus	t_{PZH} , t_{PZL}	$C_L = 50\text{pF}$ $R_L = 500\Omega$	2.0	12.5	2.0	9.8	1.5	7.8	1.5	7.3	ns

Switching Specifications Over Operating Range (Continued)

PARAMETER	SYMBOL	(NOTE 15) TEST CONDITIONS	T		AT		(NOTE 18) CT		(NOTE 18, 19) DT		UNIT
			(NOTE 16) MIN	MAX	(NOTE 16) MIN	MAX	(NOTE 16) MIN	MAX	(NOTE 16) MIN	MAX	
Output Disable Time GBA, GAB to Bus (Note 17)	t _{PHZ} , t _{PLZ}	C _L = 50pF R _L = 500Ω	2.0	9.0	2.0	6.3	1.5	6.3	1.5	6.0	ns
Propagation Delay Clock to Bus	t _{PLH} , t _{PHL}	C _L = 50pF R _L = 500Ω	2.0	9.0	2.0	6.3	1.5	5.7	1.5	5.2	ns
Propagation Delay SBA or SAB to Bus	t _{PLH} , t _{PHL}	C _L = 50pF R _L = 500Ω	2.0	9.5	2.0	7.7	1.5	6.2	1.5	5.8	ns
Setup Time HIGH or LOW, Bus to Clock	t _{SU}	C _L = 50pF R _L = 500Ω	4.0	-	2.0	-	2.0	-	2.0	-	ns
Hold Time HIGH or LOW, Bus to Clock	t _H	C _L = 50pF R _L = 500Ω	2.0	-	1.5	-	1.5	-	1.5	-	ns
Clock Pulse Width HIGH or LOW (Note 17)	t _W	C _L = 50pF R _L = 500Ω	6.0	-	5.0	-	5.0	-	5.0	-	ns

NOTES:

7. For conditions shown as Max or Min, use appropriate value specified under Electrical Specifications for the applicable device type.
8. Typical values are at V_{CC} = 5.0V, 25°C ambient and maximum loading.
9. Not more than one output should be shorted at one time. Duration of the test should not exceed one second.
10. This parameter is determined by device characterization but is not production tested.
11. Per TTL driven input (V_{IN} = 3.4V); all other inputs at V_{CC} or GND.
12. This parameter is not directly testable, but is derived for use in Total Power Supply Calculations.
13. Values for these conditions are examples of the I_{CC} formula. These limits are guaranteed but not tested.
14. I_C = I_{QUIESCENT} + I_{INPUTS} + I_{DYNAMIC}
 $I_C = I_{CC} + \Delta I_{CC} D_H N_T + I_{CCD} (f_{CP}/2 + f_I N_I)$
 I_{CC} = Quiescent Current
 ΔI_{CC} = Power Supply Current for a TTL High Input (V_{IN} = 3.4V)
 D_H = Duty Cycle for TTL Inputs High
 N_T = Number of TTL Inputs at D_H
 I_{CCD} = Dynamic Current Caused by an Input Transition Pair (HLH or LHL)
 f_{CP} = Clock Frequency for Register Devices (Zero for Non-Register Devices)
 f_I = Input Frequency
 N_I = Number of Inputs at f_I
 All currents are in milliamps and all frequencies are in megahertz.
15. See test circuit and wave forms.
16. Minimum limits are guaranteed but not tested on Propagation Delays.
17. This parameter is guaranteed but not production tested.
18. Not applicable to CD74FCT2646T, CD74FCT2652T.
19. Not applicable to CD74FCT648T.
20. Not applicable to CD74FCT651T or CD74FCT652T.

Test Circuits and Waveforms

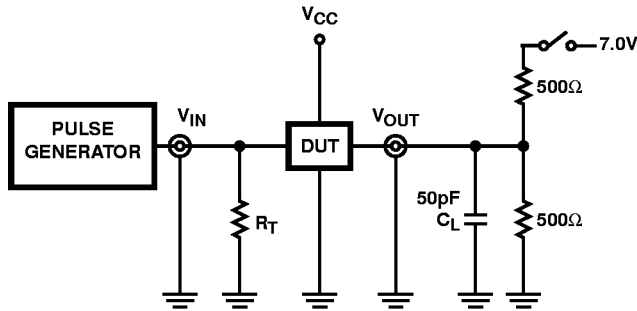

21. Pulse Generator for All Pulses: Rate $\leq 1.0\text{MHz}$; $Z_{\text{OUT}} \leq 50\Omega$; $t_f, t_r \leq 2.5\text{ns}$.

FIGURE 5. TEST CIRCUIT

SWITCH POSITION	
TEST	SWITCH
$t_{\text{PLZ}}, t_{\text{PZL}}$	Closed
$t_{\text{PHZ}}, t_{\text{PZH}}, t_{\text{PLH}}, t_{\text{PHL}}$	Open

DEFINITIONS:

C_L = Load capacitance, includes jig and probe capacitance.
 R_T = Termination resistance, should be equal to Z_{OUT} of the Pulse Generator.

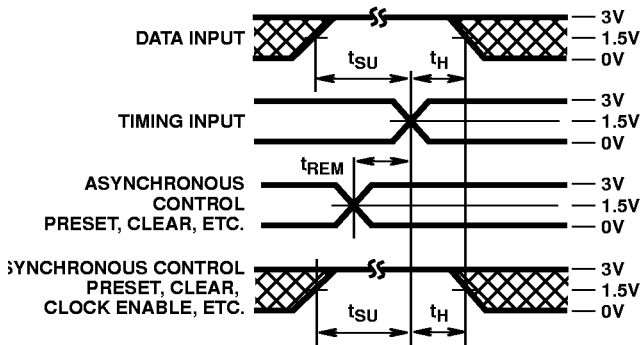

FIGURE 6. SETUP, HOLD, AND RELEASE TIMING

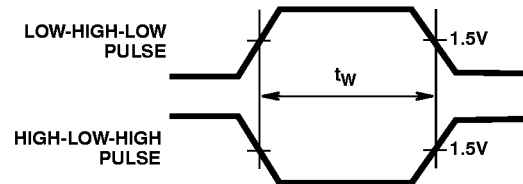

FIGURE 7. PULSE WIDTH

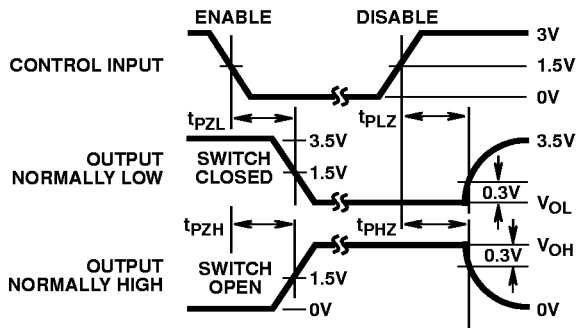

FIGURE 8. ENABLE AND DISABLE TIMING

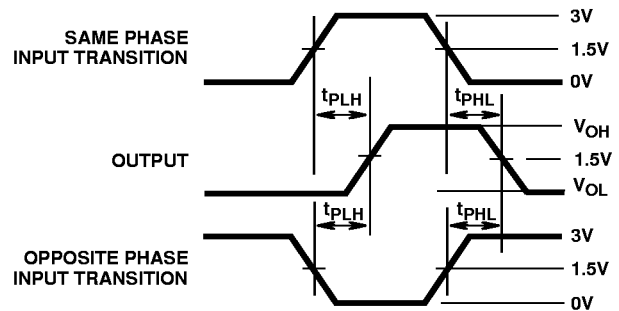

FIGURE 9. PROPAGATION DELAY