



T-23-05

# DIB 1 Amp Dual In-Line Bridge VM Series

50V, 100V, 200V, 400V, 600V, 800V and 1000V  $V_{RRM}$  Ratings

25 Amps Peak One Half Cycle Surge Current

Glass Passivated Diodes

Standard .10" — 2,54MM Dip Lead Spacing

2 Dibs Will Fit Into Standard 14 Pin Dip Socket

Moisture Resistant Epoxy Case

LTR.	INCHES	MILLIMETERS
A	.320-.335	8,13-8,51
B	.290-.310	7,37-7,87
C	.245-.255	6,22-6,48
D	.008-.012	0,20-0,30
E	.300-.350	7,62-8,89
F	.120-.130	3,05-3,30
G	.050-.080	1,27-2,03
H	.185-.215	4,70-5,46
I	.018-.022	0,46-0,56
J	.195-.205	4,95-5,21

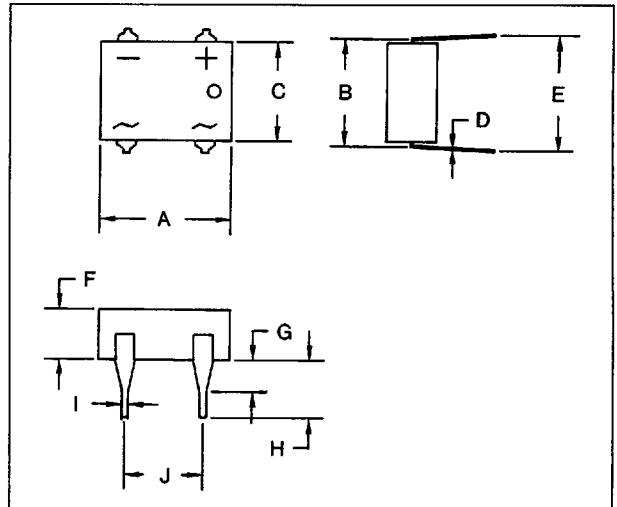

**MAXIMUM RATINGS** (At  $T_A = 25^\circ\text{C}$  unless otherwise noted)

RATING	SYMBOL	VM08	VM18	VM28	VM48	VM68	VM88	VM108
DC Blocking Voltage	$V_{RM}$							
Working Peak Reverse Voltage	$V_{RWM}$	50V	100V	200V	400V	600V	800V	1000V
Peak Repetitive Reverse Voltage	$V_{RRM}$							
RMS Reverse Voltage	$V_{RRMS}$	35V	70V	140V	280V	420V	560V	700V
Peak Surge Current, 1/2 Cycle at 60 Hz (non-rep) and $T_A = 40^\circ\text{C}$	$I_{FSM}$	25 Amps						
Peak Surge Current, 1 sec at 60 Hz and $T_A = 40^\circ\text{C}$	$I_{FRM}$	11 Amps						
DC Forward Current at $T_A = 40^\circ\text{C}$	$I_O$	1 Amp						
Junction Operating and Storage Temperature Range	$T_J, T_{STG}$	- 50 to + 150°C						
Max. Soldering Temperature and Time		10 sec. at 265°C						

**ELECTRICAL CHARACTERISTICS** (At  $T_A = 25^\circ\text{C}$  unless otherwise noted)

CHARACTERISTICS	SYMBOL	
Maximum Instantaneous Forward Voltage Drop (per diode) at 1 Amp	$V_{FM}$	1.2V
Maximum Reverse Current (per diode) at Rated $V_{RRM}$	$I_{RM}$	3.0µA
Maximum Reverse Current (per diode) at Rated $V_{RRM}$ and $T_A = 150^\circ\text{C}$	$I_{RM}$	0.5mA

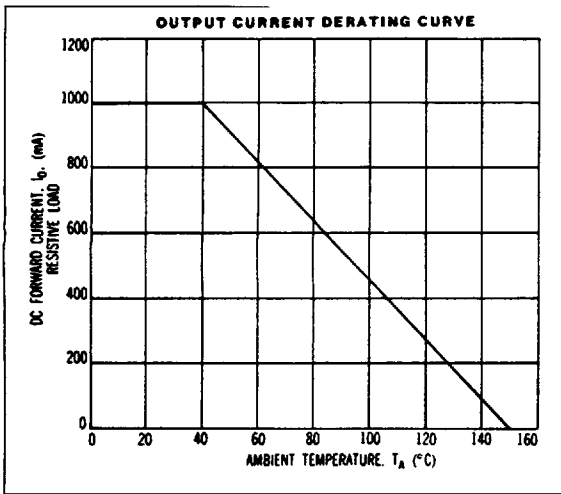

FIGURE 1

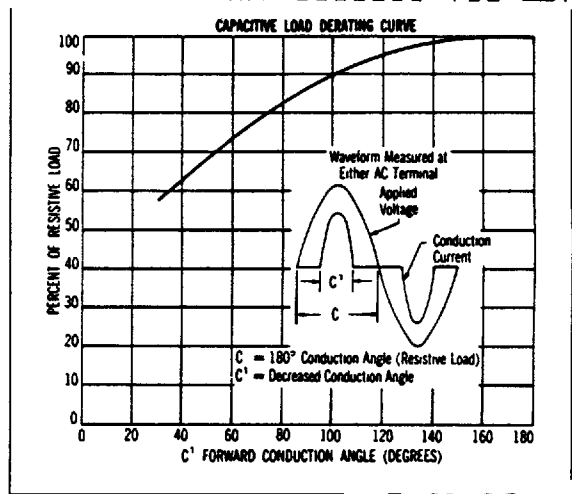

FIGURE 2

T-23-05

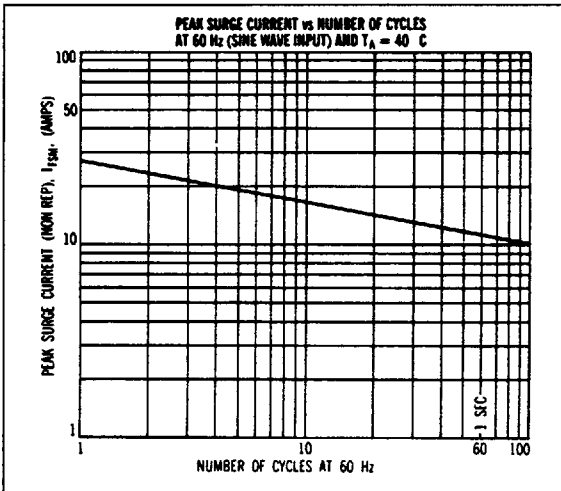

FIGURE 3

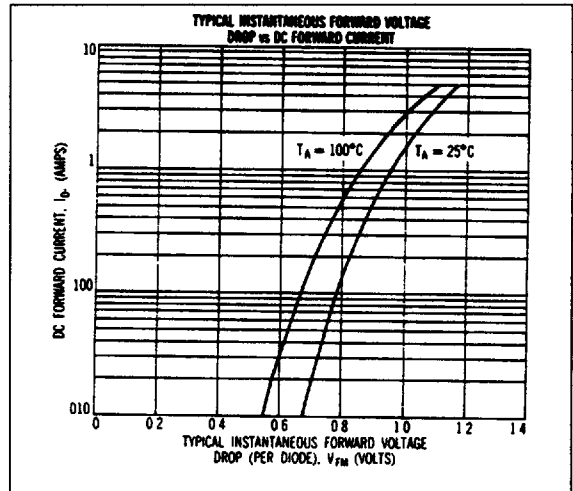

FIGURE 4

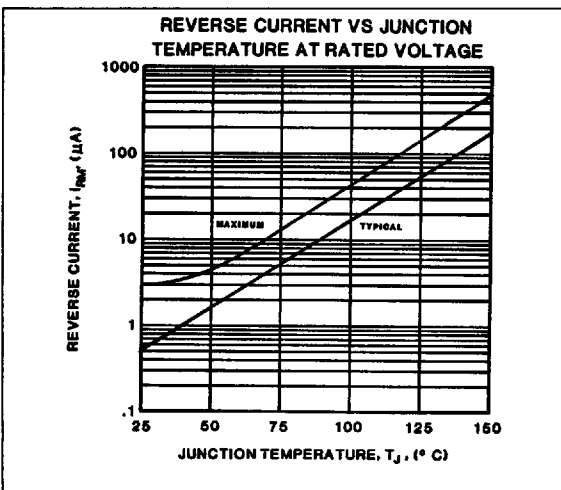

FIGURE 5