

**256K x 32, 256K x 36 and 512K x 18  
 PIPELINE 'NO WAIT' STATE BUS SRAM**

**PRELIMINARY INFORMATION  
 OCTOBER 2000**

**FEATURES**

- 100 percent bus utilization
- No wait cycles between Read and Write
- Internal self-timed write cycle
- Individual Byte Write Control
- Single R/W (Read/Write) control pin
- Clock controlled, registered address, data and control
- Interleaved or linear burst sequence control using MODE input
- Three chip enables for simple depth expansion and address pipelining for TQFP
- Power Down mode
- Common data inputs and data outputs
- $\overline{\text{CKE}}$  pin to enable clock and suspend operation
- JEDEC 100-pin TQFP, 119 PBGA package
- Single +3.3V power supply ( $\pm 5\%$ )
- NP Version: 3.3V I/O Supply Voltage
- NLP Version: 2.5V I/O Supply Voltage
- Industrial temperature available

**DESCRIPTION**

The 8 Meg 'NP' product family feature high-speed, low-power synchronous static RAMs designed to provide a burstable, high-performance, 'no wait' state, device for network and communications customers. They are organized as 262,144 words by 32 bits, 262,144 words by 36 bits and 524,288 words by 18 bits, fabricated with *ISSI's* advanced CMOS technology.

Incorporating a 'no wait' state feature, wait cycles are eliminated when the bus switches from read to write, or write to read. This device integrates a 2-bit burst counter, high-speed SRAM core, and high-drive capability outputs into a single monolithic circuit.

All synchronous inputs pass through registers are controlled by a positive-edge-triggered single clock input. Operations may be suspended and all synchronous inputs ignored when Clock Enable,  $\overline{\text{CKE}}$  is HIGH. In this state the internal device will hold their previous values.

All Read, Write and Deselect cycles are initiated by the ADV input. When the ADV is HIGH the internal burst counter is incremented. New external addresses can be loaded when ADV is LOW.

Write cycles are internally self-timed and are initiated by the rising edge of the clock inputs and when  $\overline{\text{WE}}$  is LOW. Separate byte enables allow individual bytes to be written.

A burst mode pin (MODE) defines the order of the burst sequence. When tied HIGH, the interleaved burst sequence is selected. When tied LOW, the linear burst sequence is selected.

**FAST ACCESS TIME**

Symbol	Parameter	-150*	-133	-100	Units
t <sub>KQ</sub>	Clock Access Time	3.8	4.2	5	ns
t <sub>KC</sub>	Cycle Time	6.7	7.5	10	ns
	Frequency	150	133	100	MHz

\*This speed available only in NP version

This document contains PRELIMINARY INFORMATION data. ISSI reserves the right to make changes to its products at any time without notice in order to improve design and supply the best possible product. We assume no responsibility for any errors which may appear in this publication. © Copyright 2000, Integrated Silicon Solution, Inc.

BLOCK DIAGRAM

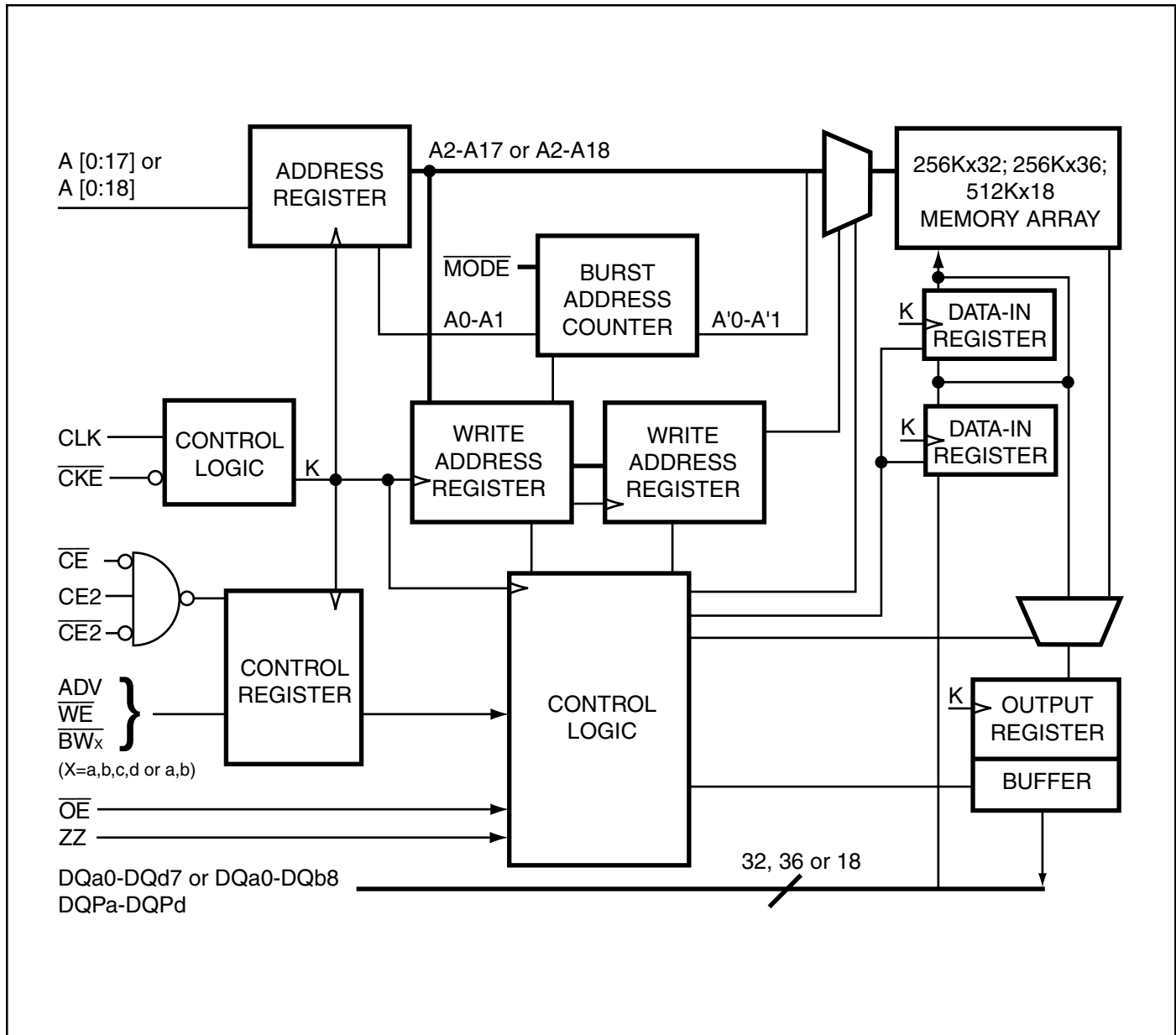

**PIN CONFIGURATION**

**119-pin PBGA (Top View) and 100-Pin TQFP**

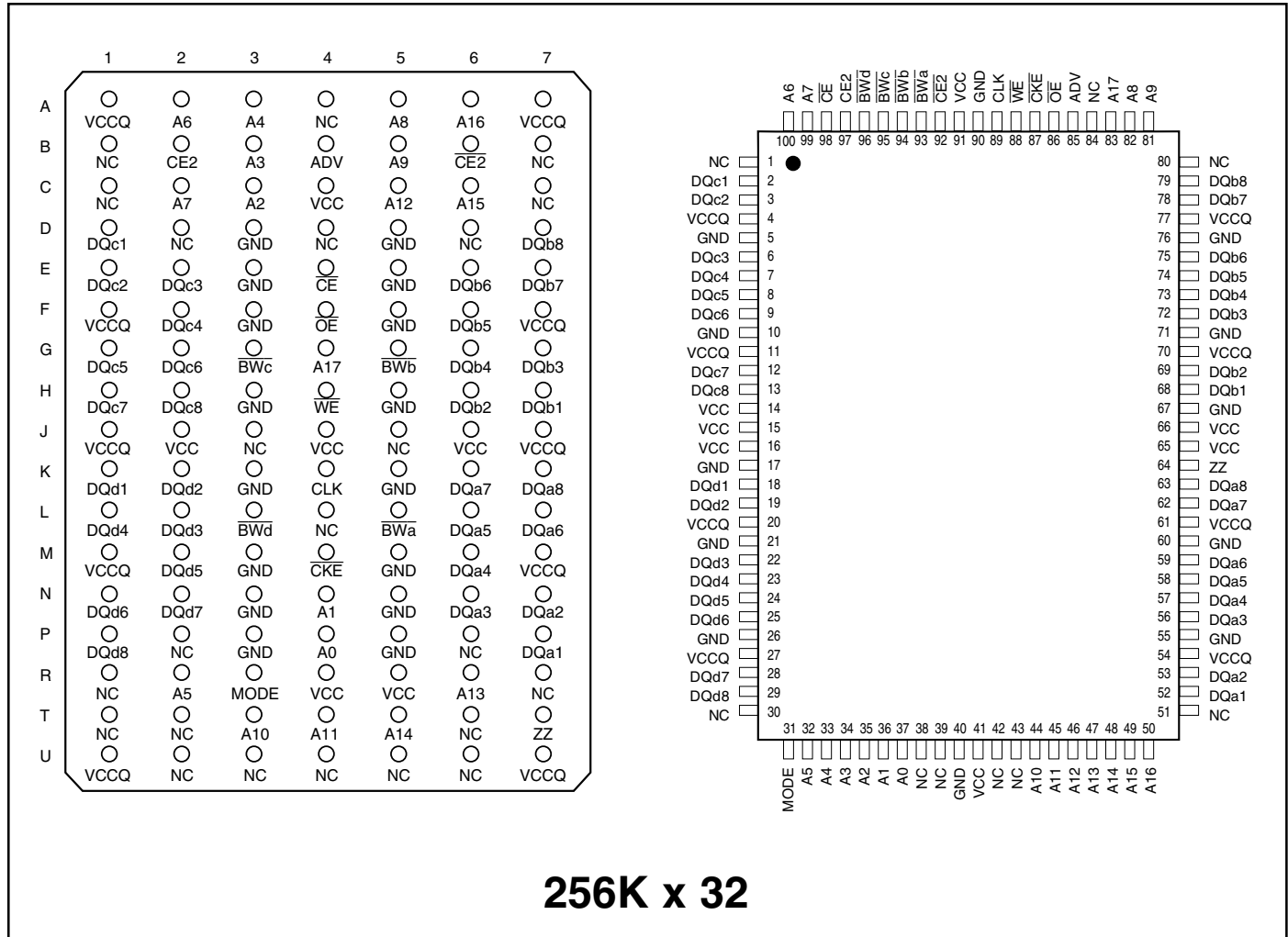

**PIN DESCRIPTIONS**

A0, A1	Synchronous Address Inputs. These pins must tied to the two LSBs of the address bus.	$\overline{CE}$ , $\overline{CE2}$ , CE2	Synchronous Chip Enable
A2-A17	Synchronous Address Inputs	$\overline{OE}$	Output Enable
CLK	Synchronous Clock	DQa-DQd	Synchronous Data Input/Output
ADV	Synchronous Burst Address Advance	MODE	Burst Sequence Mode Selection
$\overline{BWA}$ - $\overline{BWD}$	Synchronous Byte Write Enable	Vcc	+3.3V Power Supply
$\overline{WE}$	Write Enable	GND	Ground
$\overline{CKE}$	Clock Enable	Vccq	Isolated Output Buffer Supply: +3.3V/2.5V
		ZZ	Snooze Enable

## PIN CONFIGURATION

### 119-pin PBGA (Top View) and 100-Pin TQFP

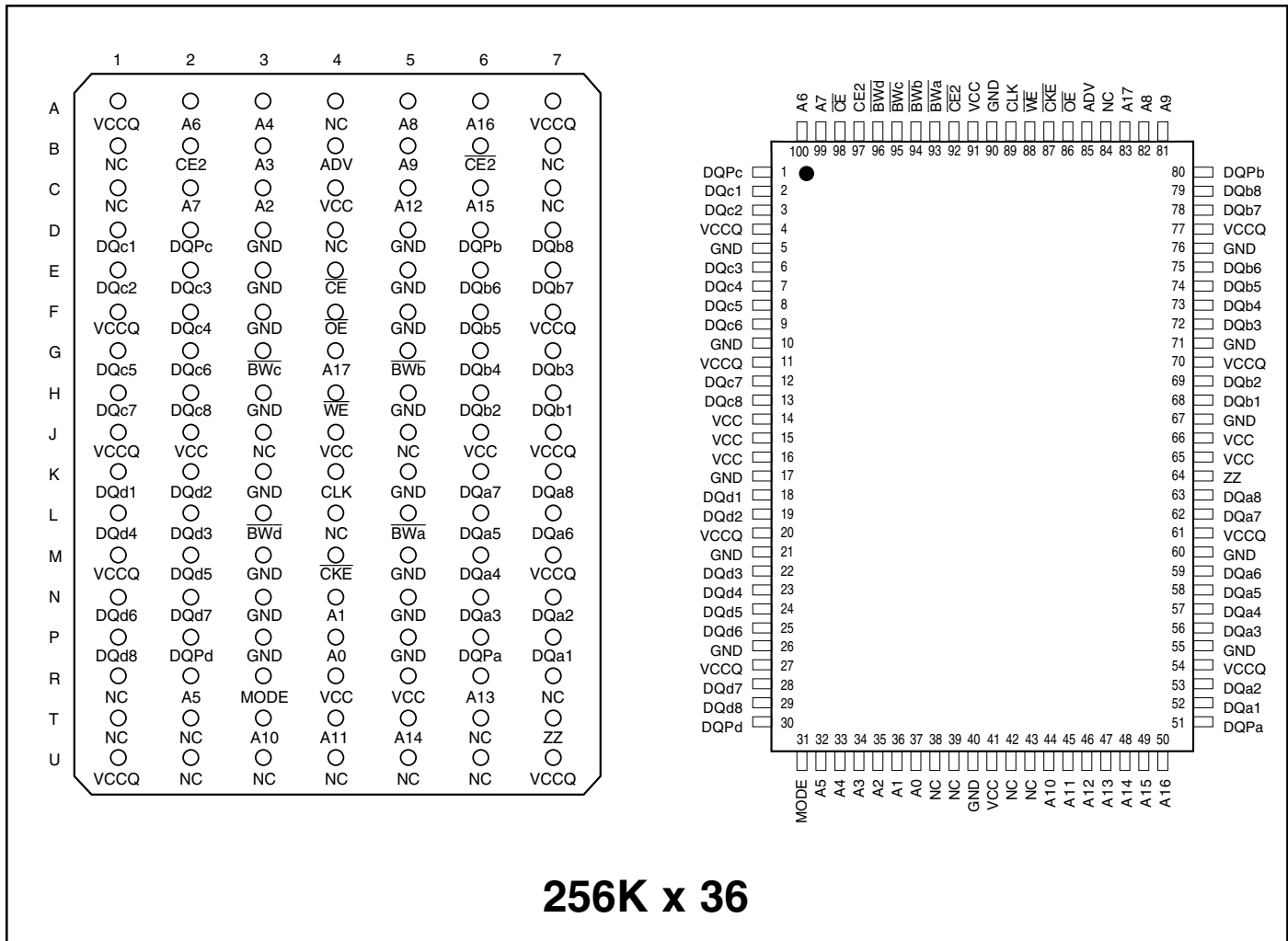

## PIN DESCRIPTIONS

A0, A1	Synchronous Address Inputs. These pins must tied to the two LSBs of the address bus.	$\overline{\text{CKE}}$	Clock Enable
A2-A17	Synchronous Address Inputs	$\overline{\text{CE}}, \overline{\text{CE2}}, \text{CE2}$	Synchronous Chip Enable
CLK	Synchronous Clock	$\overline{\text{OE}}$	Output Enable
ADV	Synchronous Burst Address Advance	DQa-DQd	Synchronous Data Input/Output
$\overline{\text{BWA}}-\overline{\text{BWD}}$	Synchronous Byte Write Enable	MODE	Burst Sequence Mode Selection
$\overline{\text{WE}}$	Write Enable	Vcc	+3.3V Power Supply
		GND	Ground
		Vccq	Isolated Output Buffer Supply: +3.3V/2.5V
		ZZ	Snooze Enable
		DQPa-DQPd	Parity Data I/O

# PIN CONFIGURATION

## 119-pin PBGA (Top View) and 100-Pin TQFP

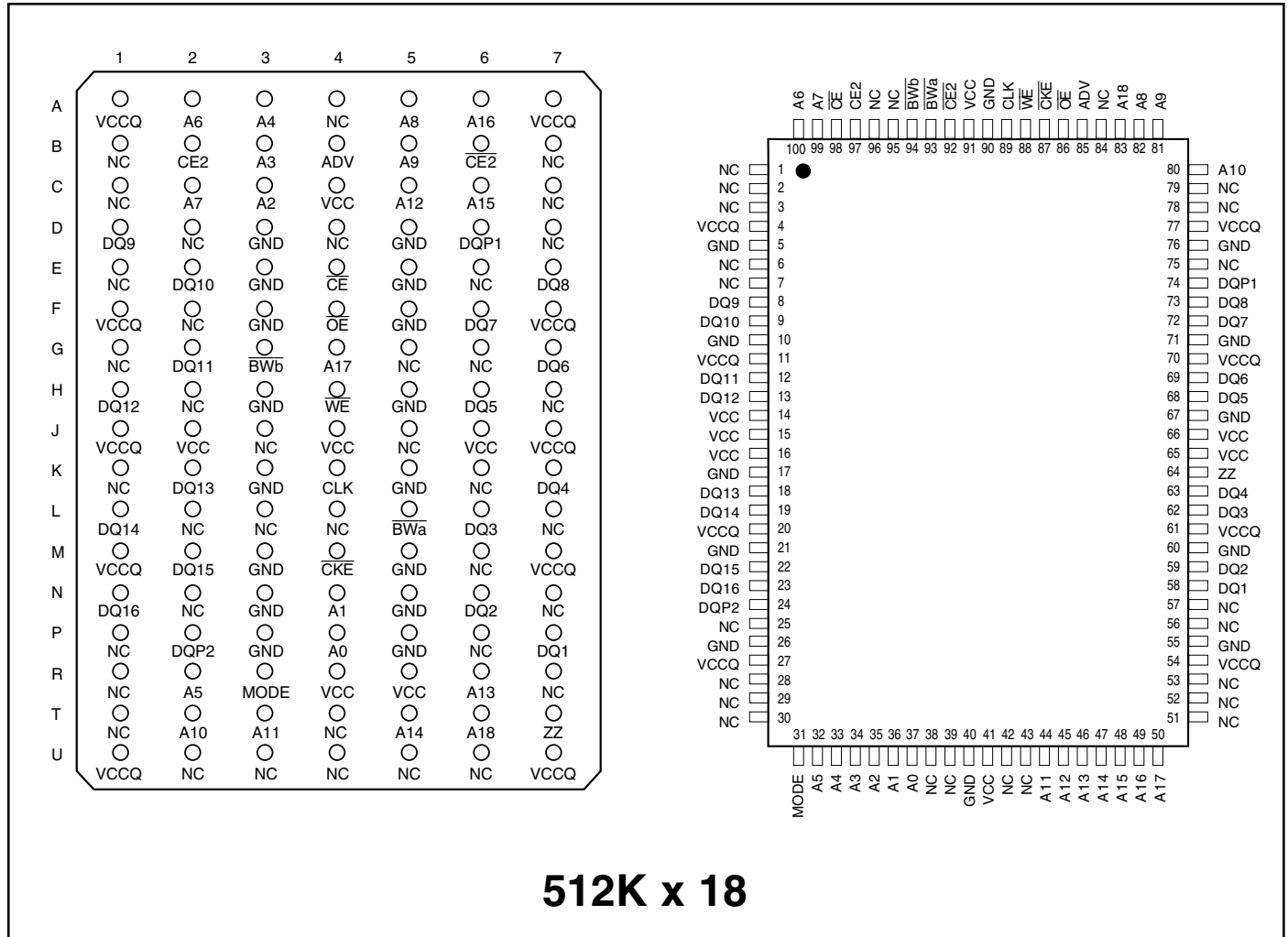

### PIN DESCRIPTIONS

A0, A1	Synchronous Address Inputs. These pins must tied to the two LSBs of the address bus.	$\overline{CE}$ , $\overline{CE2}$ , $\overline{CE2}$	Synchronous Chip Enable
A2-A18	Synchronous Address Inputs	$\overline{OE}$	Output Enable
CLK	Synchronous Clock	DQ1-DQ16	Synchronous Data Input/Output
ADV	Synchronous Burst Address Advance	MODE	Burst Sequence Mode Selection
$\overline{BWA}$ - $\overline{BWB}$	Synchronous Byte Write Enable	Vcc	+3.3V Power Supply
$\overline{WE}$	Write Enable	GND	Ground
$\overline{CKE}$	Clock Enable	Vccq	Isolated Output Buffer Supply: +3.3V/2.5V
		ZZ	Snooze Enable
		DQP1-DQP2	Parity Data I/O DQP1 is parity for DQ1-8; DQP2 is parity for DQ9-16

STATE DIAGRAM

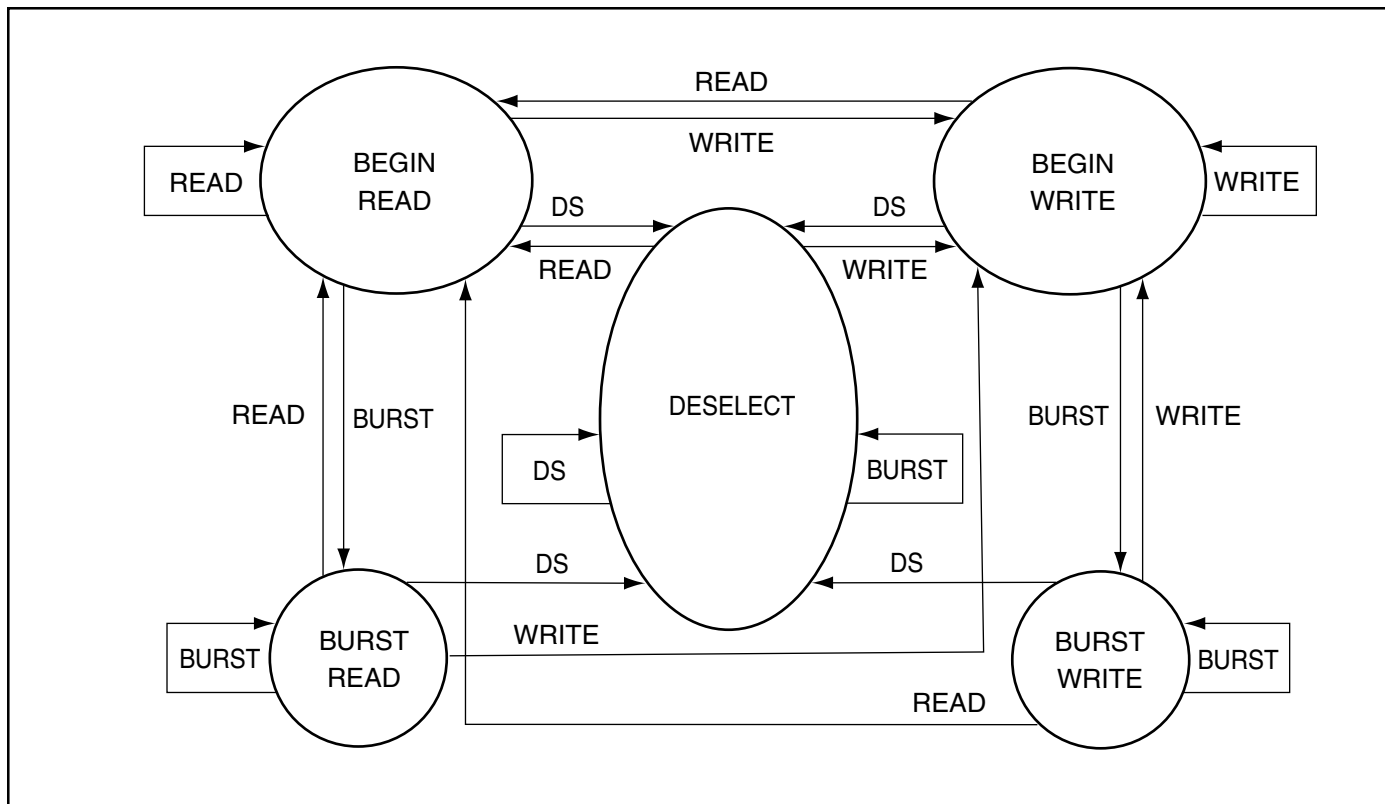

SYNCHRONOUS TRUTH TABLE<sup>(1)</sup>

Operation	Address Used	$\overline{CS1}$	CS2	$\overline{CS2}$	ADV	$\overline{WE}$	$\overline{BW_x}$	$\overline{OE}$	$\overline{CKE}$	CLK
Not Selected Continue	N/A	X	X	X	H	X	X	X	L	↑
Begin Burst Read	External Address	L	H	L	L	H	X	L	L	↑
Continue Burst Read	Next Address	X	X	X	H	X	X	L	L	↑
NOP/Dummy Read	External Address	L	H	L	L	H	X	H	L	↑
Dummy Read	Next Address	X	X	X	H	X	X	H	L	↑
Begin Burst Write	External Address	L	H	L	L	L	L	X	L	↑
Continue Burst Write	Next Address	X	X	X	H	X	L	X	L	↑
NOP/Write Abort	N/A	L	H	L	L	L	H	X	L	↑
Write Abort	Next Address	X	X	X	H	X	H	X	L	↑
Ignore Clock	Current Address	X	X	X	X	X	X	X	H	↑

Notes:

1. "X" means don't care.
2. The rising edge of clock is symbolized by ↑
3. A continue deselect cycle can only be entered if a deselect cycle is executed first.
4.  $\overline{WE} = L$  means Write operation in Write Truth Table.  
 $\overline{WE} = H$  means Read operation in Write Truth Table.
5. Operation finally depends on status of asynchronous pins ( $\overline{ZZ}$  and  $\overline{OE}$ ).

**ASYNCHRONOUS TRUTH TABLE<sup>(1)</sup>**

Operation	ZZ	$\overline{OE}$	I/O STATUS
Sleep Mode	H	X	High-Z
Read	L	L	DQ
	L	H	High-Z
Write	L	X	Din, High-Z
Deselected	L	X	High-Z

**Notes:**

1. X means "Don't Care".
2. For write cycles following read cycles, the output buffers must be disabled with  $\overline{OE}$ , otherwise data bus contention will occur.
3. Sleep Mode means power Sleep Mode where stand-by current does not depend on cycle time.
4. Deselected means power Sleep Mode where stand-by current depends on cycle time.

**WRITE TRUTH TABLE (x18)**

Operation	$\overline{WE}$	$\overline{BWa}$	$\overline{BWb}$
READ	H	X	X
WRITE BYTE a	L	L	H
WRITE BYTE b	L	H	L
WRITE ALL BYTES	L	L	L
WRITE ABORT/NOP	L	H	H

**Notes:**

1. X means "Don't Care".
2. All inputs in this table must be setup and hold time around the rising edge of CLK.

**WRITE TRUTH TABLE (x32/x36)**

Operation	$\overline{WE}$	$\overline{BWa}$	$\overline{BWb}$	$\overline{BWc}$	$\overline{BWd}$
READ	H	X	X	X	X
WRITE BYTE a	L	L	H	H	H
WRITE BYTE b	L	H	L	H	H
WRITE BYTE c	L	H	H	L	H
WRITE BYTE d	L	H	H	H	L
WRITE ALL BYTES	L	L	L	L	L
WRITE ABORT/NOP	L	H	H	H	H

**Notes:**

1. X means "Don't Care".
2. All inputs in this table must be setup and hold time around the rising edge of CLK.

**INTERLEAVED BURST ADDRESS TABLE (MODE = V<sub>CC</sub>)**

External Address A1 A0	1st Burst Address A1 A0	2nd Burst Address A1 A0	3rd Burst Address A1 A0
00	01	10	11
01	00	11	10
10	11	00	01
11	10	01	00

**LINEAR BURST ADDRESS TABLE (MODE = GND)**

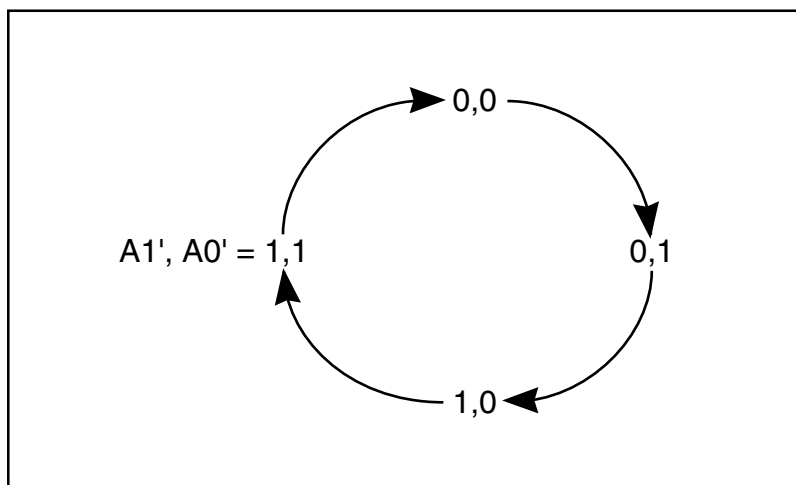

**ABSOLUTE MAXIMUM RATINGS<sup>(1)</sup>**

Symbol	Parameter	Value	Unit
T <sub>BIAS</sub>	Temperature Under Bias	-10 to +85	°C
T <sub>STG</sub>	Storage Temperature	-65 to +150	°C
P <sub>D</sub>	Power Dissipation	1.6	W
I <sub>OUT</sub>	Output Current (per I/O)	100	mA
V <sub>IN</sub> , V <sub>OUT</sub>	Voltage Relative to GND for I/O Pins	-0.5 to V <sub>CCQ</sub> + 0.3	V
V <sub>IN</sub>	Voltage Relative to GND for for Address and Control Inputs	-0.3 to 4.6	V

**Notes:**

1. Stress greater than those listed under ABSOLUTE MAXIMUM RATINGS may cause permanent damage to the device. This is a stress rating only and functional operation of the device at these or any other conditions above those indicated in the operational sections of this specification is not implied. Exposure to absolute maximum rating conditions for extended periods may affect reliability.
2. This device contains circuitry to protect the inputs against damage due to high static voltages or electric fields; however, precautions may be taken to avoid application of any voltage higher than maximum rated voltages to this high-impedance circuit.
3. This device contains circuitry that will ensure the output devices are in High-Z at power up.



**OPERATING RANGE**

Range	Ambient Temperature	V <sub>CC</sub>	V <sub>CCQ</sub>
Commercial	0°C to +70°C	3.3V ± 5%	3.3V ± 5%
		3.3V ± 5%	2.5V ± 5%
Industrial	-40°C to +85°C	3.3V ± 5%	3.3V ± 5%

**DC ELECTRICAL CHARACTERISTICS** (Over Operating Range)

Symbol	Parameter	Test Conditions	2.5V		3.3V		Unit
			Min.	Max.	Min.	Max.	
V <sub>OH</sub>	Output HIGH Voltage	I <sub>OH</sub> = -4.0 mA (3.3V) I <sub>OH</sub> = 1.0 mA (2.5V)	2.0	—	2.4	—	V
V <sub>OL</sub>	Output LOW Voltage	I <sub>OL</sub> = 8.0 mA (3.3V) I <sub>OL</sub> = 1.0 mA (2.5V)	—	0.4	—	0.4	V
V <sub>IH</sub>	Input HIGH Voltage		1.7	V <sub>CC</sub> + 0.3	2.0	V <sub>CC</sub> + 0.3	V
V <sub>IL</sub>	Input LOW Voltage		-0.3	0.7	-0.3	0.8	V
I <sub>LI</sub>	Input Leakage Current	GND ≤ V <sub>IN</sub> ≤ V <sub>CC</sub> ( <sup>1</sup> )	-5	5	-5	5	μA
I <sub>LO</sub>	Output Leakage Current	GND ≤ V <sub>OUT</sub> ≤ V <sub>CCQ</sub> , $\overline{OE} = V_I$	-5	5	-5	5	μA

**POWER SUPPLY CHARACTERISTICS**(<sup>1</sup>) (Over Operating Range)

Symbol	Parameter	Test Conditions	-150* MAX		-133 MAX		-100 MAX		Unit
			x18	x32/36	x18	x32/36	x18	x32/36	
I <sub>CC</sub>	AC Operating Supply Current	Device Selected, Com. $\overline{OE} = V_{IH}$ , ZZ ≤ V <sub>IL</sub> , Ind. All Inputs ≤ 0.2V OR ≥ V <sub>CC</sub> - 0.2V, Cycle Time ≥ t <sub>CC</sub> min.	380	380	350	350	300	300	mA
I <sub>SB</sub>	Standby Current TTL Input	Device Deselected, Com. V <sub>CC</sub> = Max., Ind. All Inputs ≤ 0.2V OR ≥ V <sub>CC</sub> - 0.2V, ZZ ≤ V <sub>IL</sub> , f = Max.	105	105	90	90	80	80	mA
I <sub>SBI</sub>	Standby Current CMOS Input	Device Deselected, Com. V <sub>CC</sub> = Max., Ind. V <sub>IN</sub> ≤ GND + 0.2V OR ≥ V <sub>CC</sub> - 0.2V f = 0	20	20	20	20	20	20	mA
							25	25	

\*This speed available only in NP version

**Note:**

- MODE pin has an internal pullup and should be tied to V<sub>CC</sub> or GND. It exhibits ±30 μA maximum leakage current when tied to ≤ GND + 0.2V or ≥ V<sub>CC</sub> - 0.2V.

**CAPACITANCE<sup>(1,2)</sup>**

Symbol	Parameter	Conditions	Max.	Unit
C <sub>IN</sub>	Input Capacitance	V <sub>IN</sub> = 0V	6	pF
C <sub>OUT</sub>	Input/Output Capacitance	V <sub>OUT</sub> = 0V	8	pF

**Notes:**

1. Tested initially and after any design or process changes that may affect these parameters.
2. Test conditions: T<sub>A</sub> = 25°C, f = 1 MHz, V<sub>CC</sub> = 3.3V.

**3.3V I/O AC TEST CONDITIONS**

Parameter	Unit
Input Pulse Level	0V to 3.0V
Input Rise and Fall Times	1.5 ns
Input and Output Timing and Reference Level	1.5V
Output Load	See Figures 1 and 2

**3.3V I/O OUTPUT LOAD EQUIVALENT**

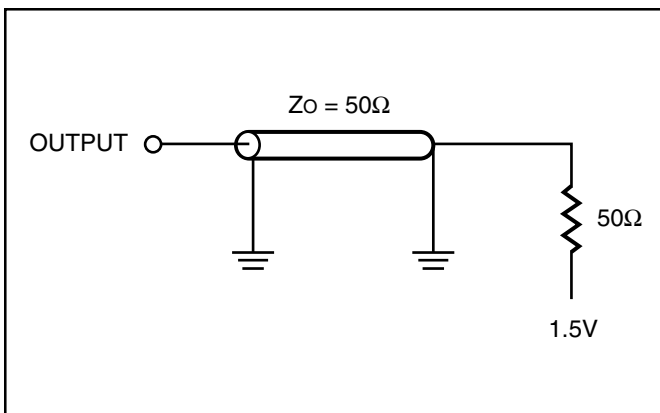

Figure 1

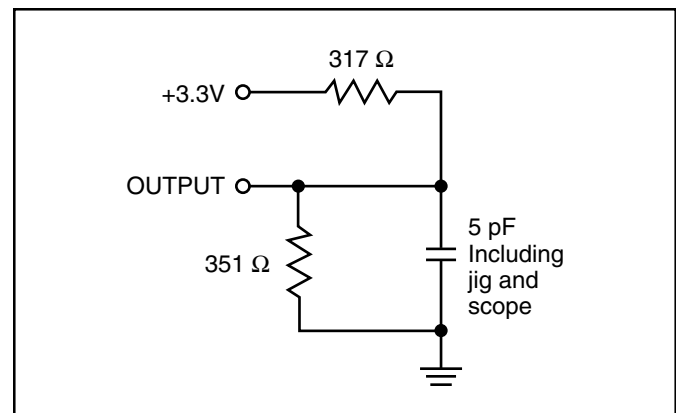

Figure 2

**2.5V I/O AC TEST CONDITIONS**

Parameter	Unit
Input Pulse Level	0V to 2.5V
Input Rise and Fall Times	1.5 ns
Input and Output Timing and Reference Level	1.25V
Output Load	See Figures 3 and 4

**2.5V I/O OUTPUT LOAD EQUIVALENT**

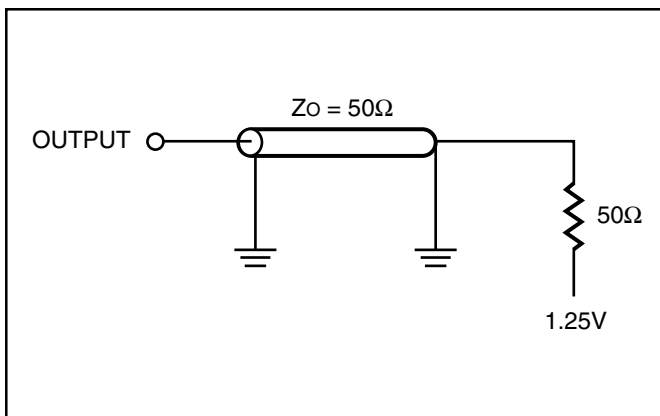

Figure 3

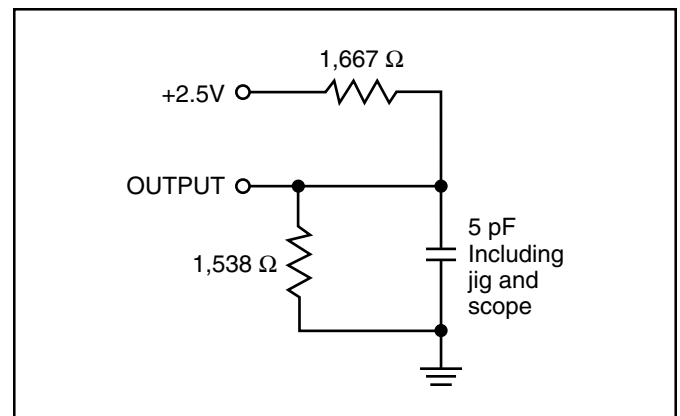

Figure 4

**READ/WRITE CYCLE SWITCHING CHARACTERISTICS<sup>(1)</sup>** (Over Operating Range)

Symbol	Parameter	-150*		-133		-100		Unit
		Min.	Max.	Min.	Max.	Min.	Max.	
fmax	Clock Frequency	—	150	—	133	—	100	MHz
t <sub>kc</sub>	Cycle Time	6.7	—	7.5	—	10	—	ns
t <sub>kh</sub>	Clock High Time	2.5	—	3	—	3	—	ns
t <sub>kl</sub>	Clock Low Time	2.5	—	3	—	3	—	ns
t <sub>kq</sub>	Clock Access Time	—	3.8	—	4.2	—	5	ns
t <sub>kqx</sub> <sup>(2)</sup>	Clock High to Output Invalid	1.5	—	1.5	—	1.5	—	ns
t <sub>kqlz</sub> <sup>(2,3)</sup>	Clock High to Output Low-Z	0	—	0	—	0	—	ns
t <sub>kqhz</sub> <sup>(2,3)</sup>	Clock High to Output High-Z	—	3	—	3.5	—	3.5	ns
t <sub>oEQ</sub>	Output Enable to Output Valid	—	3.8	—	4.2	—	5	ns
t <sub>oELZ</sub> <sup>(2,3)</sup>	Output Enable to Output Low-Z	0	—	0	—	0	—	ns
t <sub>oEHZ</sub> <sup>(2,3)</sup>	Output Disable to Output High-Z	—	3.5	—	3.5	—	3.5	ns
t <sub>as</sub>	Address Setup Time	1.5	—	1.5	—	1.5	—	ns
t <sub>ws</sub>	Read/Write Setup Time	1.5	—	1.5	—	1.5	—	ns
t <sub>ces</sub>	Chip Enable Setup Time	1.5	—	1.5	—	1.5	—	ns
t <sub>se</sub>	Clock Enable Setup Time	1.5	—	1.5	—	1.5	—	ns
t <sub>avs</sub>	Address Advance Setup Time	1.5	—	1.5	—	1.5	—	ns
t <sub>ds</sub>	Data Setup Time	2.0	—	2.0	—	2.0	—	ns
t <sub>ah</sub>	Address Hold Time	0.5	—	0.5	—	0.5	—	ns
t <sub>he</sub>	Clock Enable Hold Time	0.5	—	0.5	—	0.5	—	ns
t <sub>wh</sub>	Write Hold Time	0.5	—	0.5	—	0.5	—	ns
t <sub>ceh</sub>	Chip Enable Hold Time	0.5	—	0.5	—	0.5	—	ns
t <sub>advh</sub>	Address Advance Hold Time	0.5	—	0.5	—	0.5	—	ns
t <sub>dh</sub>	Data Hold Time	0.5	—	0.5	—	0.5	—	ns
t <sub>pds</sub>	ZZ High to Power Down	—	2	—	2	—	2	cyc
t <sub>pds</sub>	ZZ Low to Power Down	—	2	—	2	—	2	cyc

\*This speed available only in NP version

**Notes:**

1. Configuration signal MODE is static and must not change during normal operation.
2. Guaranteed but not 100% tested. This parameter is periodically sampled.
3. Tested with load in Figure 2.

**SLEEP MODE ELECTRICAL CHARACTERISTICS**

Symbol	Parameter	Conditions	Min.	Max.	Unit
ISB2	Current during SLEEP MODE	ZZ ≥ Vih		10	mA
tPDS	ZZ active to input ignored		2		cycle
tPUS	ZZ inactive to input sampled		2		cycle
tzZI	ZZ active to SLEEP current		2		cycle
tRZZI	ZZ inactive to exit SLEEP current		0		ns

**SLEEP MODE TIMING**

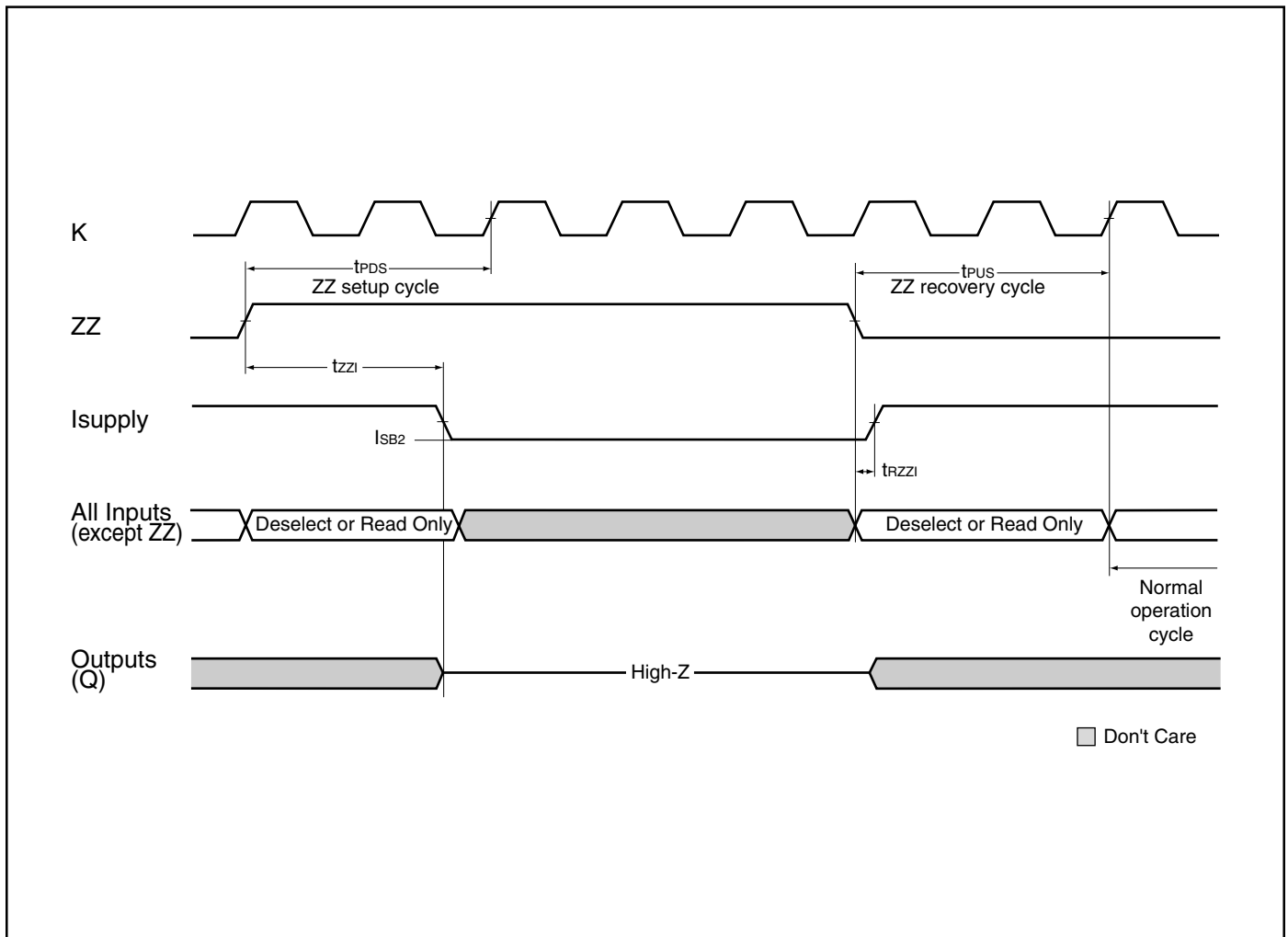

READ CYCLE TIMING

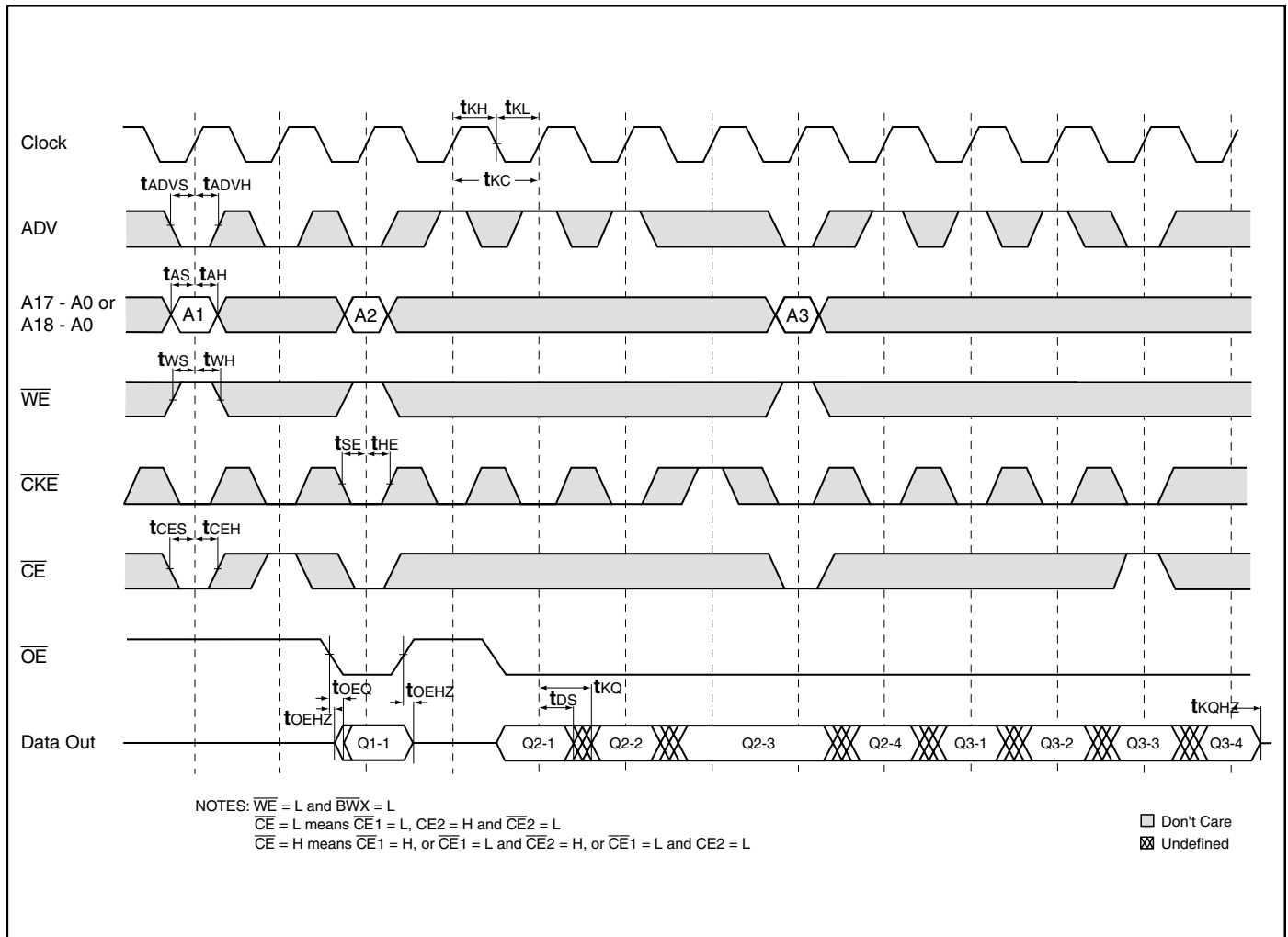

WRITE CYCLE TIMING

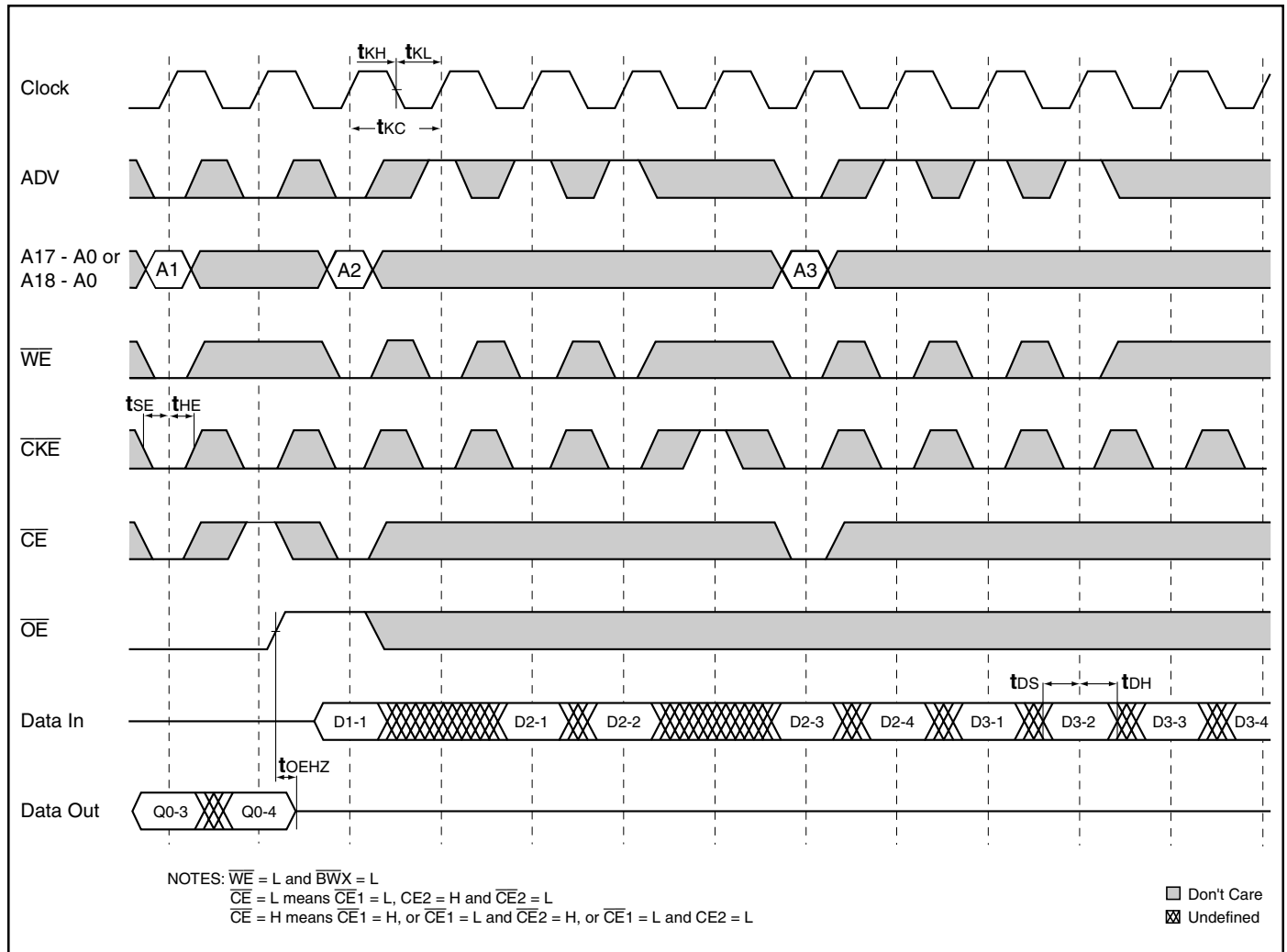

**SINGLE READ/WRITE CYCLE TIMING**

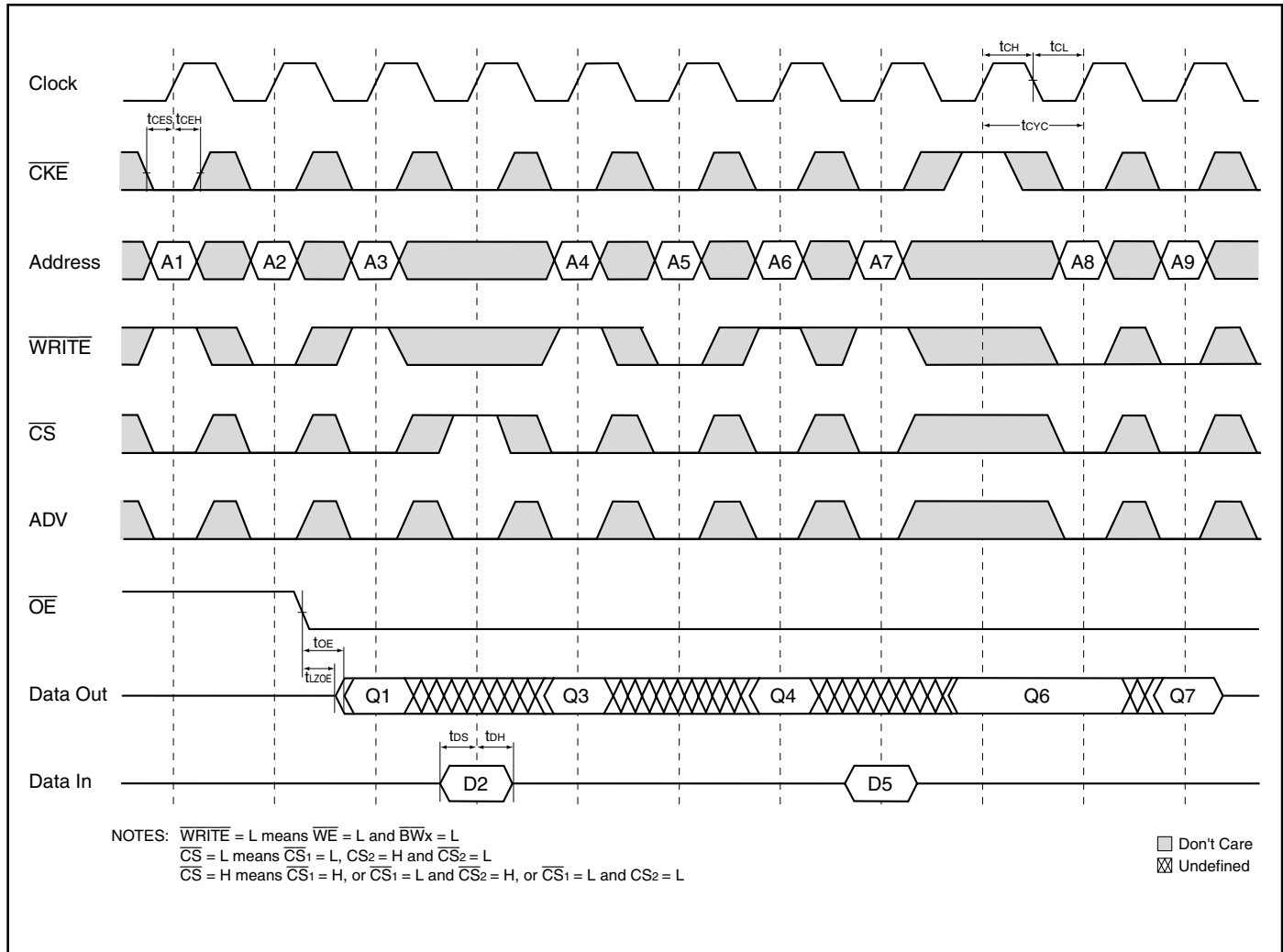



**$\overline{\text{CKE}}$  OPERATION TIMING**

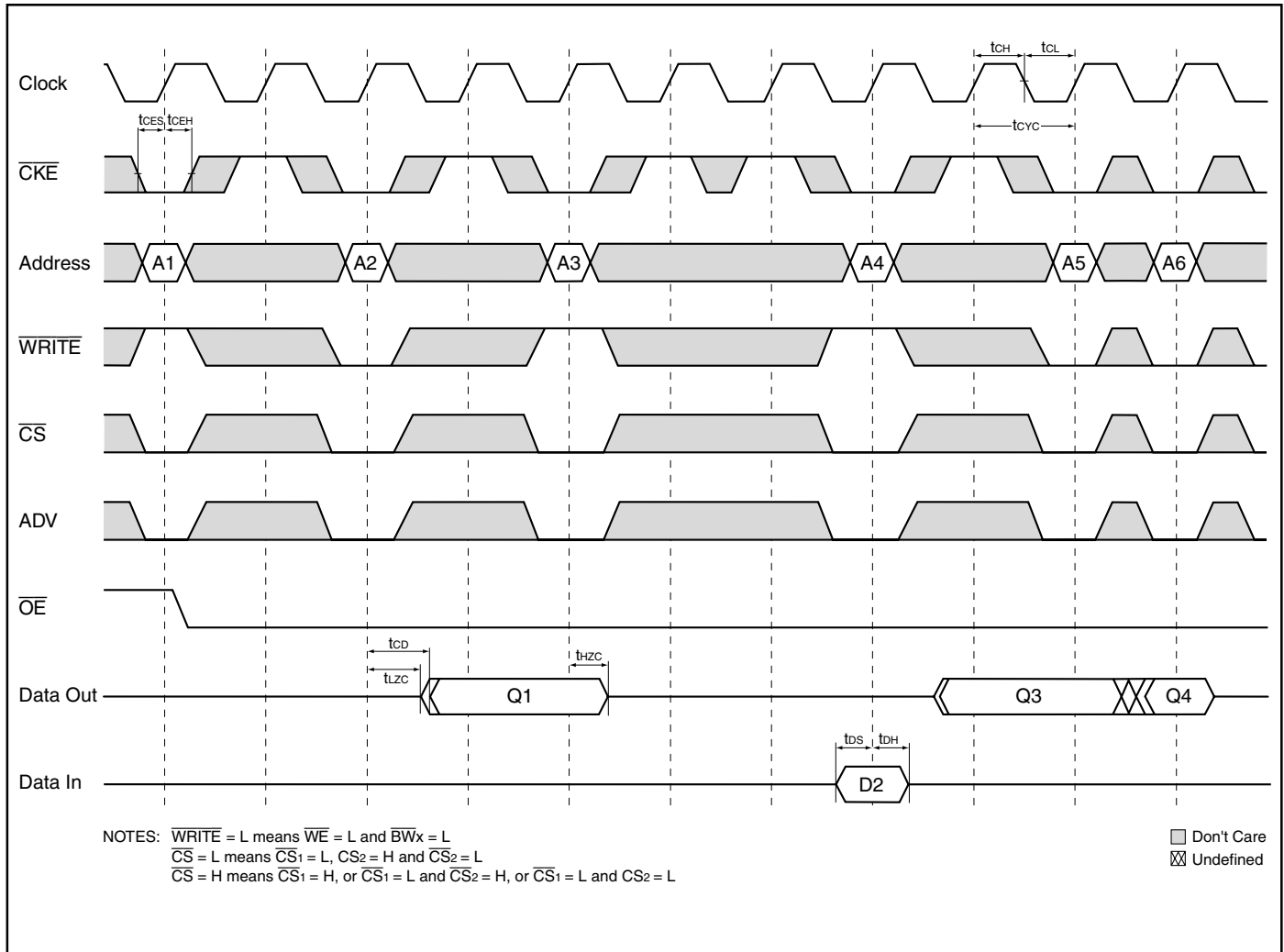

**$\overline{CS}$  OPERATION TIMING**

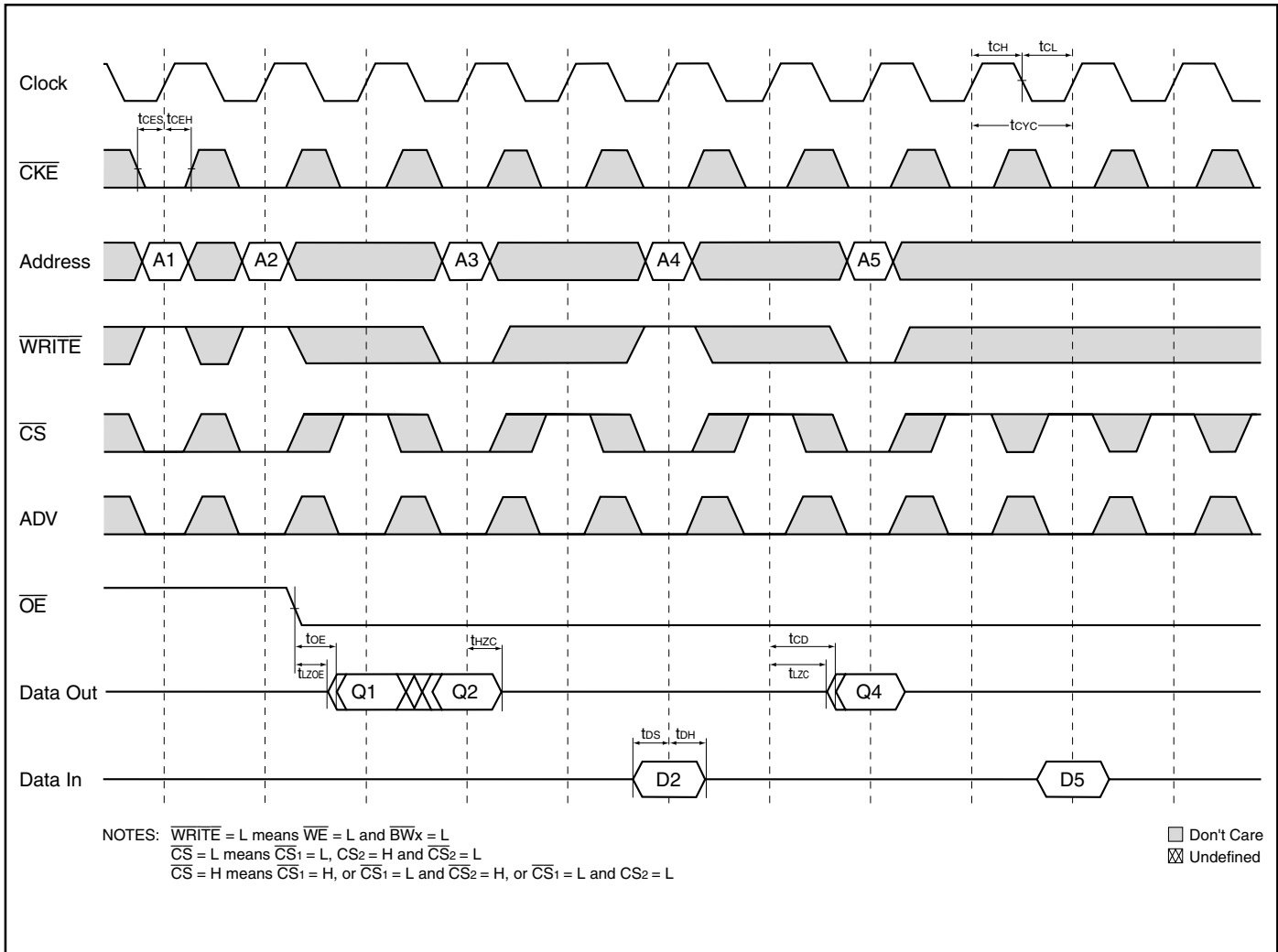

**ORDERING INFORMATION**

**Commercial Range: 0°C to +70°C**

Frequency	Order Part Number	Package
<b>256Kx32</b>		
150	IS61NP25632-150TQ	TQFP
	IS61NP25632-150B	PBGA
133	IS61NP25632-133TQ	TQFP
	IS61NP25632-133B	PBGA
100	IS61NP25632-5TQ	TQFP
	IS61NP25632-5B	PBGA
<b>256Kx36</b>		
150	IS61NP25636-150TQ	TQFP
	IS61NP25636-150B	PBGA
133	IS61NP25636-133TQ	TQFP
	IS61NP25636-133B	PBGA
100	IS61NP25636-5TQ	TQFP
	IS61NP25636-5B	PBGA
<b>512Kx18</b>		
150	IS61NP51218-150TQ	TQFP
	IS61NP51218-150B	PBGA
133	IS61NP51218-133TQ	TQFP
	IS61NP51218-133B	PBGA
100	IS61NP51218-5TQ	TQFP
	IS61NP51218-5B	PBGA

**Industrial Range: -40°C to +85°C**

Frequency	Order Part Number	Package
<b>256Kx32</b>		
100	IS61NP25632-5TQI	TQFP
<b>256Kx36</b>		
100	IS61NP25636-5TQI	TQFP
<b>512Kx18</b>		
100	IS61NP51218-5TQI	TQFP

**ORDERING INFORMATION**

**Commercial Range: 0°C to +70°C**

Frequency	Order Part Number	Package
<b>256Kx32</b>		
133	IS61NLP25632-133TQ IS61NLP25632-133B	TQFP PBGA
100	IS61NLP25632-5TQ IS61NLP25632-5B	TQFP PBGA
<b>256Kx36</b>		
133	IS61NLP25636-133TQ IS61NLP25636-133B	TQFP PBGA
100	IS61NLP25636-5TQ IS61NLP25636-5B	TQFP PBGA
<b>512Kx18</b>		
133	IS61NLP51218-133TQ IS61NLP51218-133B	TQFP PBGA
100	IS61NLP51218-5TQ IS61NLP51218-5B	TQFP PBGA

**Industrial Range: -40°C to +85°C**

Frequency	Order Part Number	Package
<b>256Kx32</b>		
100	IS61NLP25632-5TQI	TQFP
<b>256Kx36</b>		
100	IS61NLP25636-5TQI	TQFP
<b>512Kx18</b>		
100	IS61NLP51218-5TQI	TQFP



***Integrated Silicon Solution, Inc.***

2231 Lawson Lane  
 Santa Clara, CA 95054  
 Tel: 1-800-379-4774  
 Fax: (408) 588-0806  
 E-mail: sales@issi.com  
**www.issi.com**