

FEATURES

- 12-Bit resolution
- Integral nonlinearity error $\pm 1/2$ LSB, max.
- Differential nonlinearity error $\pm 3/4$ LSB, max.
- MIL-STD-883 high-reliability versions available
- Input register
- 3 μ s fast settling time
- Guaranteed monotonicity over full temperature range

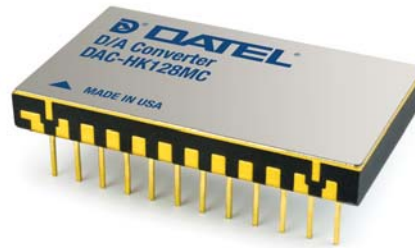

PRODUCT OVERVIEW

The DAC-HK Series hybrid D/A converters are highperformance 12-bit devices with a fast settling voltage output. They incorporate a level-controlled input storage register and are specifically designed for systems applications such as data bus interfacing with computers. When the "load" input is high, data in the storage register is held, and when the load input is low, data is transferred through to the DAC. There are two basic models available by coding option: binary and two's complement. The output voltage ranges are externally pinprogrammable and include: 0 to +5V, 0 to +10V, ± 2.5 V, ± 5 V and ± 10 V.

The DAC-HK Series contains a precision zener reference circuit. This eliminates code-dependent ground currents by routing current from the positive supply to the internal ground node as determined by the R-2R ladder network. The internal feedback resistors for the on-board amplifier track the ladder network resistors, enhancing temperature performance. The excellent tracking of the resistors results in a differential nonlinearity tempco of ± 2 ppm/ $^{\circ}$ C maximum. The temperature coefficient of gain is ± 20 ppm/ $^{\circ}$ C maximum, and the tempco of zero is ± 5 ppm/ $^{\circ}$ C maximum.

INPUT/OUTPUT CONNECTIONS			
PIN	FUNCTION	PIN	FUNCTION
1	BIT 1 (MSB)	24	REFERENCE OUT
2	BIT 2	23	GAIN ADJUST
3	BIT 3	22	+15V SUPPLY
4	BIT 4	21	GROUND
5	BIT 5	20	SUMMING JUNCTION
6	BIT 6	19	20V RANGE
7	BIT 7	18	10V RANGE
8	BIT 8	17	BIPOLAR OFFSET
9	BIT 9	16	LOAD
10	BIT 10	15	VOLTAGE OUTPUT
11	BIT 11	14	-15V SUPPLY
12	BIT 12 (LSB)	13	+5V SUPPLY

BLOCK DIAGRAM

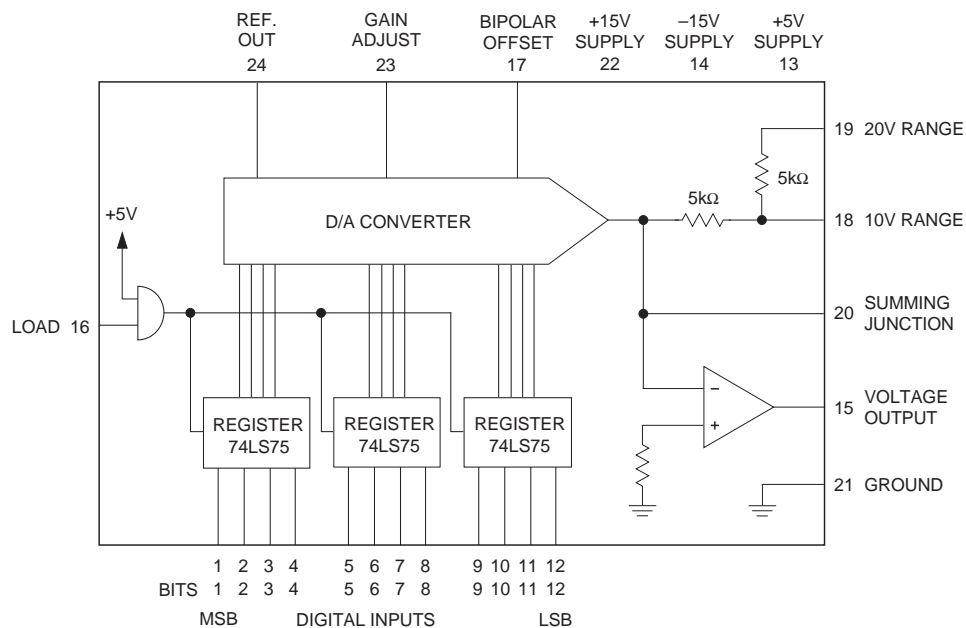

Figure 1. DAC-HK Functional Block Diagram

FUNCTIONAL SPECIFICATIONS

(Typical at +25°C and ±15V and +5V supplies unless otherwise noted.)

DESCRIPTION	
INPUTS	
Resolution	12 bits
Coding, Unipolar Output	Straight binary
Coding, Bipolar Output	Offset binary, two's complement ①
Input Logic Level, Bit ON ("1")	+2.0V to +5.5V
Input Logic Level, Bit OFF ("0")	0V to +0.8V
Logic Loading	1 LSTTL load
Load Input ②	High ("1") = hold data Low ("0") = transfer data
Load Input Loading	3 LSTTL loads
PERFORMANCE ④	
Nonlinearity Error, max.	±1/2LSB
Differential Nonlinearity Error, max.	±3/4LSB
Gain Error, Before Trimming	±0.1% ③
Zero Error, Before Trimming	±0.1% of FSR ③
Gain Tempco, max.	±20ppm/°C
Zero Tempco, Unipolar, max.	±5ppm/°C of FSR
Offset Tempco, Bipolar, max.	±10ppm/°C of FSR
Diff. Nonlinearity Tempco, max.	±2ppm/°C of FSR
Monotonicity	Guaranteed over temperature
Settling Time, 5V Change	3µs
Settling Time, 10V Change	3µs
Settling Time, 20V Change	4µs
Settling Time, 1LSB Change	800ns
Slew Rate	±20V/µs
Power Supply Rejection	±0.002%FSR/%
OUTPUTS	
Output Voltage Ranges, Unipolar ⑤	0 to +5V, 0 to +10V
Output Voltage Ranges, Bipolar ⑤	±2.5V ±5V ±10V
Output Current	±5mA min.
Output Impedance	0.05Ω
POWER REQUIREMENTS	
Power Supply Voltages ⑥	+15V, ±0.5V at 15mA -15V, ±0.5V at 30mA +5V, ±0.25V at 65mA
PHYSICAL/ENVIRONMENTAL	
Operating Temperature Range, Case	0°C to +70°C (BGC/BGC-C, BMC/BMC-C) -40°C to +85°C (BME, BME-C) -55°C to +125°C (BMM, BMM-C, 883, -C/883)
Storage Temperature Range	-65°C to +125°C
Package Type	24-pin DDIP
Weight	0.22 ounces (6.3 grams)

Footnotes:

- ① For two's complement coding, order the "-2" model as described in Ordering Information.
- ② Logic levels are the same as for data inputs.
- ③ Initial errors are trimmable to zero. See Connection Diagram.
- ④ FSR is full scale range and is 10V for 0 to +10V output range, 20V for ±10V output range, etc.
- ⑤ By external pin connection.
- ⑥ For ±12V, +5V operation, contact factory.

ABSOLUTE MAXIMUM RATINGS

PARAMETERS	LIMITS	UNITS
Positive Supply, Pin 22	+18	Volts
Negative Supply, Pin 14	-18	Volts
Logic Supply, Pin 13	+5.25	Volts
Digital Input Voltage, Pins 1-12 & 16	+5.5	Volts
Output Current, Pin 15	±20	mA
Lead Temperature (soldering, 10s)	300	°C

TECHNICAL NOTES

1. It is recommended that these converters be operated with local supply bypass capacitors of 1µF (tantalum type) at the +15V, -15V and +5V supply pins. The capacitors should be connected as close to the pins as possible. In high RFI noise environments, these capacitors should be shunted with 0.01µF ceramic capacitors.
2. The analog, digital and power grounds should be separated from each other as close as possible to pin 21 where they all must come together.
3. The "load" control pin is a level-triggered input which causes the register to hold data with a high input and transfer data to the DAC with a low input.
4. A setup time of 50ns minimum must be allowed for the input data. The DAC output voltage begins to change when the register output changes.
5. If the reference output terminal (pin 24) is used, an operational amplifier in non-inverting mode should be used as a buffer. Current drawn from pin 24 should be limited to ±10µA in order not to affect the T.C. of the reference.

CALIBRATION PROCEDURE

Select the desired output voltage range and connect the converter as shown in the Output Range Selection Table and the Connection Diagrams. Refer to the Coding Tables.

Unipolar Operation

1. **Zero Adjustment.** Set the input digital code to 0000 0000 0000 and adjust the ZERO ADJ. potentiometer to give 0.0000V output.
2. **Gain Adjustment.** Set the input digital code to 1111 1111 1111 (straight binary) and adjust the GAIN ADJ. potentiometer to give the full-scale output voltage shown in Table 1.

Bipolar Operation

1. **Offset Adjustment.** Set the digital input code to 0000 0000 0000 (offset binary) or 1000 0000 0000 (two's complement) and adjust the OFFSET ADJ. potentiometer to give the negative full-scale output voltage shown in Table 2.
2. **Gain Adjustment.** Set the digital input code to 1111 1111 1111 (offset binary) or 0111 1111 1111 (two's complement) and adjust the GAIN ADJ. potentiometer to give the positive full-scale output voltage shown in Table 2.

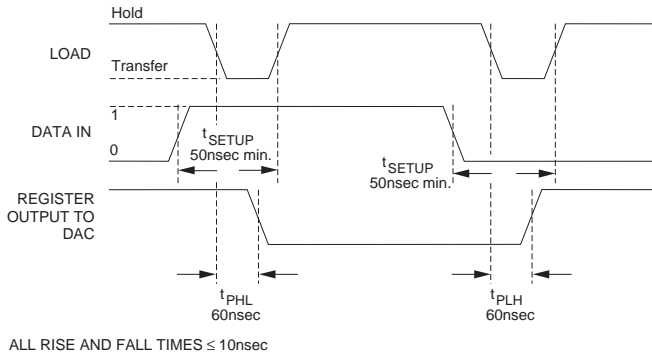

Figure 2. DAC-HK Timing

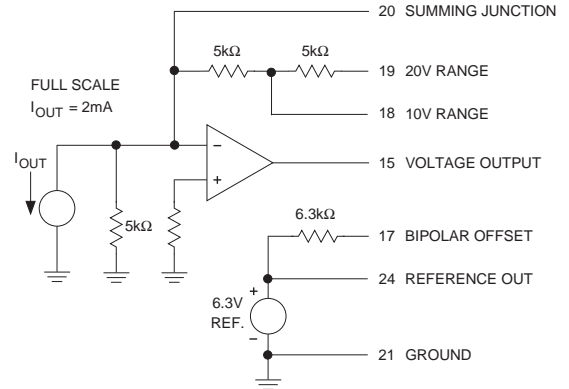

Figure 3. Output Circuit

CONNECTION DIAGRAMS

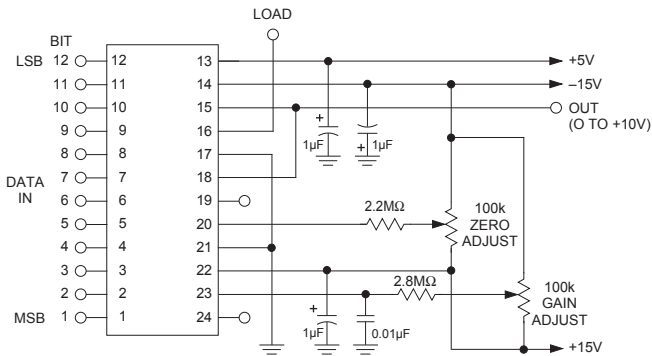

Figure 4. Unipolar Operation (0 to +10V)

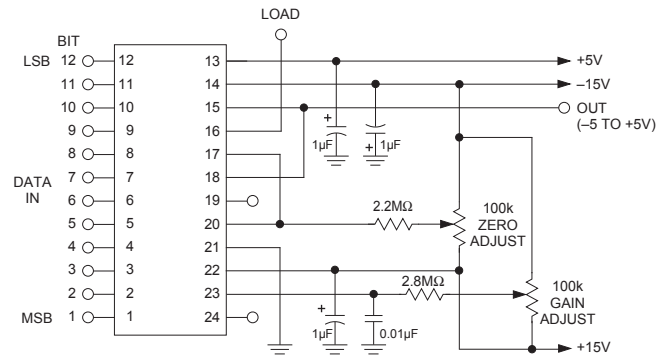

Figure 5. Bipolar Operation (±5V)

APPLICATIONS

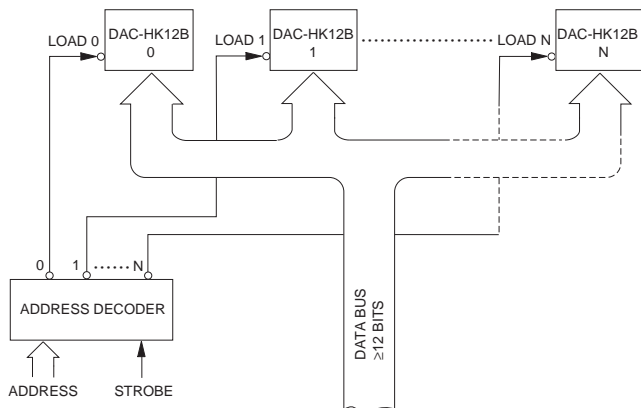

Figure 6. Interfacing to ≥12-Bit Data Bus

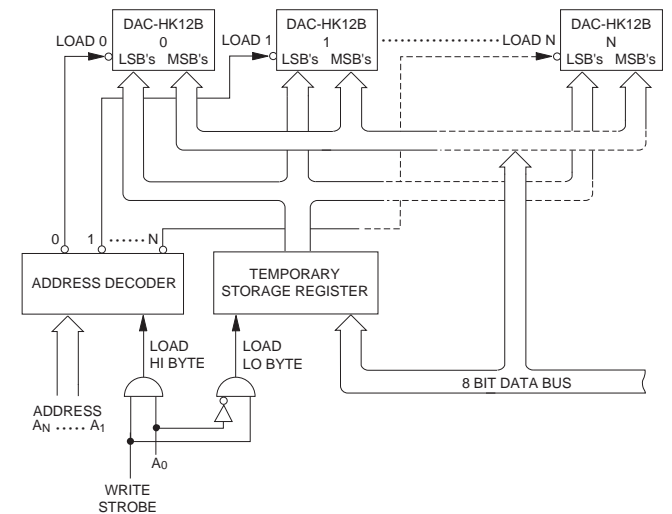

Figure 7. Interfacing to 8-Bit Data Bus

CODING TABLES

STRAIGHT BINARY			OUTPUT RANGES	
MSB		LSB	0 to +10V	0 to +5V
1111	1111	1111	+9.9976	+4.9988
1100	0000	0000	+7.5000	+3.7500
1000	0000	0000	+5.0000	+2.5000
0100	0000	0000	+2.5000	+1.2500
0000	0000	0001	+0.0024	+0.0012
0000	0000	0000	0.0000	0.0000

Table 1. Unipolar Operation

OFFSET BINARY			TWO'S COMPLEMENT			OUTPUT RANGES		
MSB		LSB	MSB		LSB	$\pm 10V$	$\pm 5V$	$\pm 2.5V$
1111	1111	1111	0111	1111	1111	+9.9951	+4.9976	+2.4988
1100	0000	0000	0100	0000	0000	+5.0000	+2.5000	+1.2500
1000	0000	0000	0000	0000	0000	0.0000	0.0000	0.0000
0100	0000	0000	1100	0000	0000	-5.0000	-2.5000	-1.2500
0000	0000	0001	1000	0000	0001	-9.9951	-4.9976	-2.4988
0000	0000	0000	1000	0000	0000	-10.0000	-5.0000	-2.5000

Table 2. Bipolar Operation

RANGE	CONNECT THESE PINS TOGETHER		
$\pm 10V$	15 & 19	17 & 20	
$\pm 5V$	15 & 18	17 & 20	
$\pm 2.5V$	15 & 18	17 & 20	19 & 20
+10V	15 & 18	17 & 21	
+5V	15 & 18	17 & 21	19 & 20

Table 3. Output Range Selection

MECHANICAL DIMENSIONS (inches (mm))

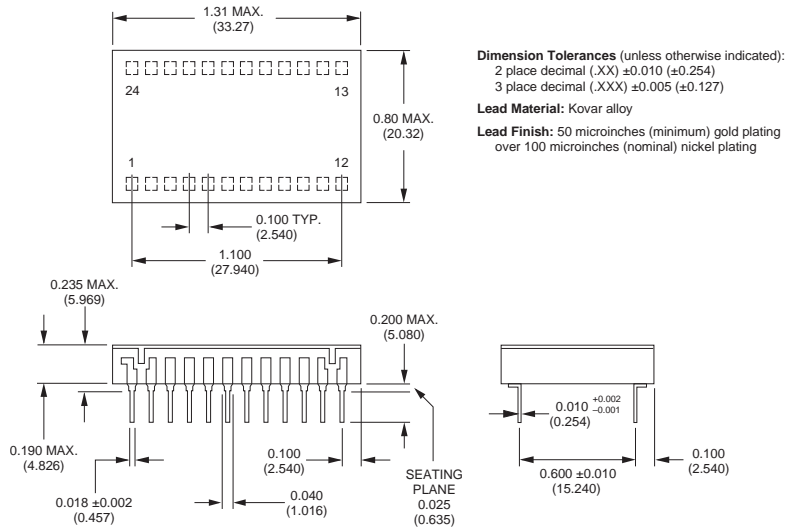

ORDERING INFORMATION

MODEL NUMBER	OPERATING TEMP RANGE	BITS	SEAL	RoHS
Binary Coding				
DAC-HK12BGC	0 to +70°C	12	Epoxy	No
DAC-HK12BGC-C	0 to +70°C	12	Epoxy	Yes
DAC-HK12BMC	0 to +70°C	12	Hermetic	No
DAC-HK12BMC-C	0 to +70°C	12	Hermetic	Yes
DAC-HK12BME	-40 to +100°C	12	Hermetic	No
DAC-HK12BME-C	-40 to +100°C	12	Hermetic	No
DAC-HK12BMM	-55 to +125°C	12	Hermetic	Yes
DAC-HK12BMM-C	-55 to +125°C	12	Hermetic	No
DAC-HK12BMC-QL	-55 to +125°C	12	Hermetic	Yes
DAC-HKB/883	-55 to +125°C	12	Hermetic	No
DAC-HKB-C/883	-55 to +125°C	12	Hermetic	No
5962-8952801XC	-55 to +125°C	12	Hermetic	Yes
5962-8952801XA	-55 to +125°C	12	Hermetic	No
Two's Complement Coding				
DAC-HK12BGC-2	0 to +70°C	12	Epoxy	No
DAC-HK12BGC-2-C	0 to +70°C	12	Epoxy	Yes
DAC-HK12BMC-2	0 to +70°C	12	Hermetic	No
DAC-HK12BMC-2-C	0 to +70°C	12	Hermetic	Yes
DAC-HK12BME-2	-40 to +100°C	12	Hermetic	No
DAC-HK12BME-2-C	-40 to +100°C	12	Hermetic	No
DAC-HK12BMM-2	-55 to +125°C	12	Hermetic	Yes
DAC-HK12BMM-2-C	-55 to +125°C	12	Hermetic	No
DAC-HK12BMM-QL	-55 to +125°C	12	Hermetic	Yes
DAC-HK12BMC-QL-C	-55 to +125°C	12	Hermetic	No
DAC-HKB-2/883	-55 to +125°C	12	Hermetic	No
DAC-HKB-2-C/883	-55 to +125°C	12	Hermetic	Yes
5962-8952802XC	-55 to +125°C	12	Hermetic	No
5962-8952802XA	-55 to +125°C	12	Hermetic	No

The MIL-STD-883 units are available under DESC

Drawing Number 5962-89528. Contact DATEL for 883 product specifications.

DATEL is a registered trademark of

Murata Power Solutions, Inc.

11 Cabot Boulevard, Mansfield, MA 02048-1151 USA

ITAR and ISO 9001/14001 REGISTERED

Murata Power Solutions, Inc. makes no representation that the use of its products in the circuits described herein, or the use of other technical information contained herein, will not infringe upon existing or future patent rights. The descriptions contained herein do not imply the granting of licenses to make, use, or sell equipment constructed in accordance therewith. Specifications are subject to change without notice.

© 2013 Murata Power Solutions, Inc.