

Features

- Glass Passivated Die Construction
- 2.0W Power Dissipation
- 2.7V – 330V Nominal Zener Voltage
- 5% Standard Vz Tolerance
- Low Inductance
- For Use in Voltage Regulator or Reference
- Plastic Case Material has UL Flammability Classification Rating 94V-0

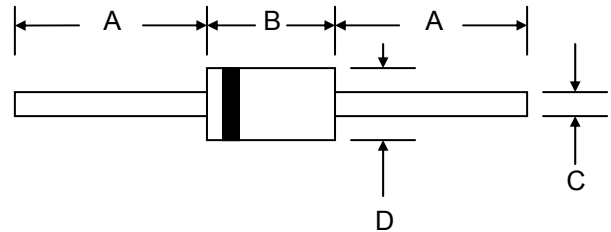

Mechanical Data

- Case: DO-41, Molded Plastic
- Terminals: Plated Leads Solderable per MIL-STD-202, Method 208
- Polarity: Cathode Band
- Weight: 0.35 grams (approx.)
- Mounting Position: Any
- Marking: Type Number
- **Lead Free: For RoHS / Lead Free Version, Add "-LF" Suffix to Part Number, See Page 6**

DO-41		
Dim	Min	Max
A	25.4	—
B	4.06	5.21
C	0.71	0.864
D	2.00	2.72
All Dimensions in mm		

Maximum Ratings @ $T_A=25^{\circ}\text{C}$ unless otherwise specified

Characteristic	Symbol	Value	Unit
Power Dissipation at $T_L = 60^{\circ}\text{C}$ (Note 1)	P_D	2.0	W
Forward Voltage @ $I_F = 200\text{mA}$	V_F	1.2	V
Thermal Resistance, Junction to Ambient (Note 2)	R_{JA}	105	$^{\circ}\text{C/W}$
Thermal Resistance, Junction to Lead (Note 1)	R_{JL}	45	$^{\circ}\text{C/W}$
Operating and Storage Temperature Range	T_J, T_{STG}	-65 to +150	$^{\circ}\text{C}$

Note: 1. Measured at lead length 3/8" (9.5mm) from body.
 2. Mounted on FR-4 PCB with 2.0 x 2.0mm copper pads and track width 1.0mm, length 25mm.

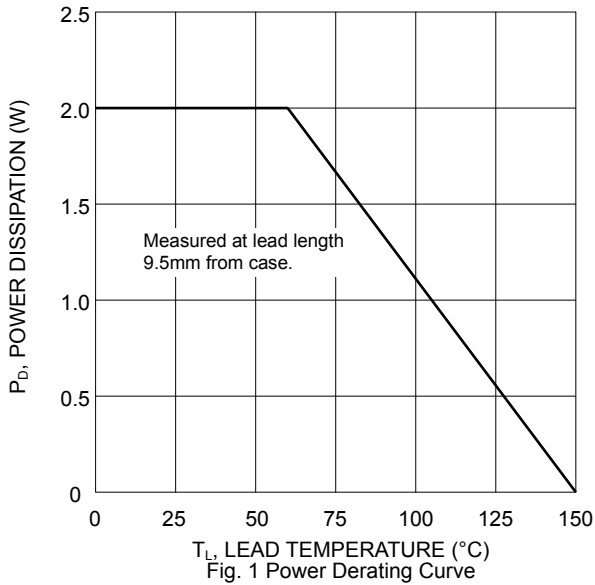

Fig. 1 Power Derating Curve

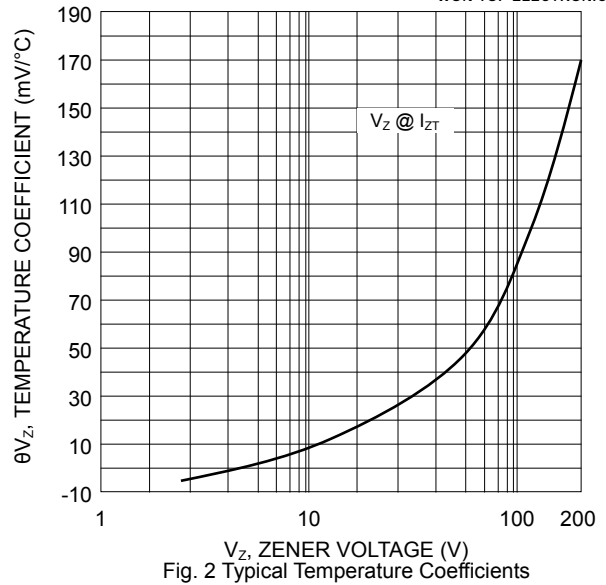

Fig. 2 Typical Temperature Coefficients

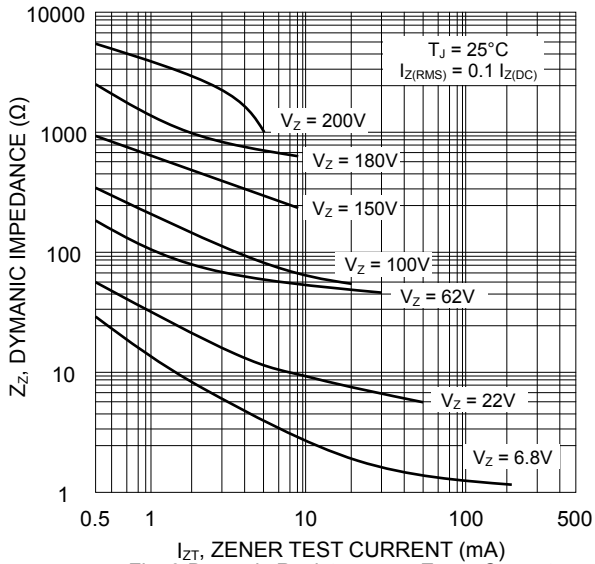

Fig. 3 Dynamic Resistance vs. Zener Current

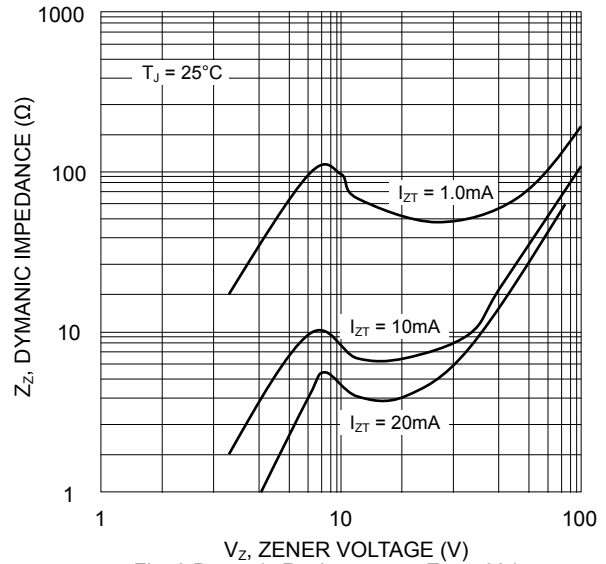

Fig. 3 Dynamic Resistance vs. Zener Voltage

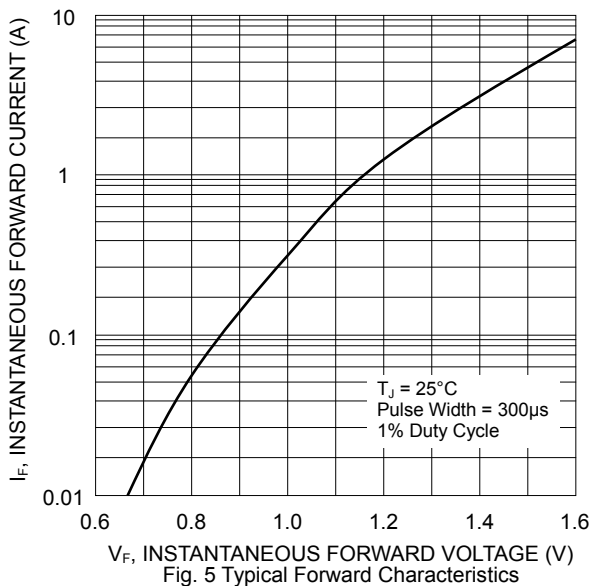

Fig. 5 Typical Forward Characteristics

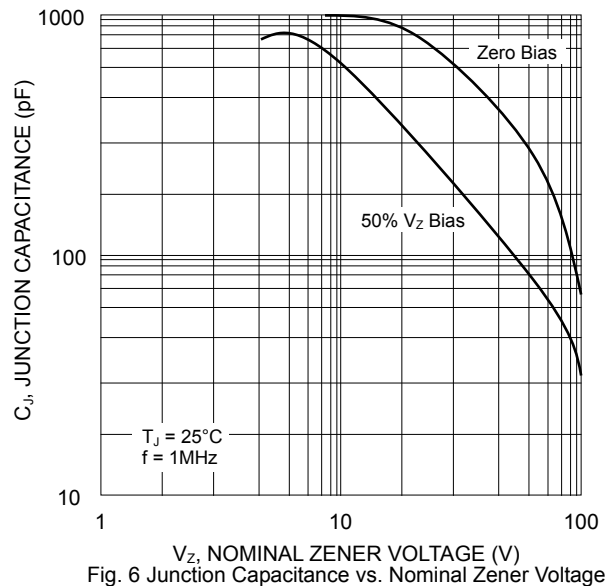

Fig. 6 Junction Capacitance vs. Nominal Zener Voltage

Electrical Characteristics (@T_A=25°C unless otherwise specified) Table 1

Type Number (Note 1)	Nominal Zener Voltage (Note 2)	Test Current	Maximum Zener Impedance (Note 3)			Maximum Leakage Current		Max DC Zener Current
	V _Z @ I _{ZT}	I _{ZT}	Z _{ZT} @ I _{ZT}	Z _{ZK} @ I _{ZK}	I _{ZK}	I _R @ V _R		I _{ZM}
	(V)	(mA)	()	()	(mA)	(μA)	(V)	(mA)
2EZ2.7D5	2.7	180.0	10.0	400	1.00	100	1.0	670
2EZ3.0D5	3.0	160.0	8.0	400	1.00	100	1.0	603
2EZ3.3D5	3.3	145.0	8.0	400	1.00	80	1.0	548
2EZ3.6D5	3.6	139.0	5.0	400	1.00	80	1.0	504
2EZ3.9D5	3.9	128.0	5.0	400	1.00	30	1.0	468
2EZ4.3D5	4.3	116.0	4.5	400	1.00	20	1.0	434
2EZ4.7D5	4.7	106.0	4.5	550	1.00	5.0	1.0	386
2EZ5.1D5	5.1	98.0	3.5	600	1.00	5.0	1.0	356
2EZ5.6D5	5.6	89.5	2.5	500	1.00	5.0	2.0	324
2EZ6.2D5	6.2	80.5	1.5	700	1.00	5.0	3.0	292
2EZ6.8D5	6.8	73.5	2.0	700	1.00	5.0	4.0	266
2EZ7.5D5	7.5	66.5	2.0	700	0.50	5.0	5.0	242
2EZ8.2D5	8.2	61.0	2.3	700	0.50	5.0	6.0	220
2EZ9.1D5	9.1	55.0	2.5	700	0.50	3.0	7.0	200
2EZ10D5	10	50.0	3.5	700	0.25	3.0	7.6	182
2EZ11D5	11	45.5	4.0	700	0.25	1.0	8.4	166
2EZ12D5	12	41.5	4.5	700	0.25	1.0	9.1	152
2EZ13D5	13	38.5	5.0	700	0.25	0.5	9.9	138
2EZ14D5	14	35.7	5.5	700	0.25	0.5	10.6	130
2EZ15D5	15	33.4	7.0	700	0.25	0.5	11.4	122
2EZ16D5	16	31.2	8.0	700	0.25	0.5	12.2	114
2EZ17D5	17	29.4	9.0	750	0.25	0.5	13.0	107
2EZ18D5	18	27.8	10.0	750	0.25	0.5	13.7	100
2EZ19D5	19	26.3	11.0	750	0.25	0.5	14.4	95
2EZ20D5	20	25.0	11.0	750	0.25	0.5	15.2	90
2EZ22D5	22	22.8	12.0	750	0.25	0.5	16.7	82
2EZ24D5	24	20.8	13.0	750	0.25	0.5	18.2	76
2EZ27D5	27	18.5	18.0	750	0.25	0.5	20.6	68
2EZ30D5	30	16.6	20.0	1000	0.25	0.5	22.5	60
2EZ33D5	33	15.1	23.0	1000	0.25	0.5	25.1	55
2EZ36D5	36	13.9	25.0	1000	0.25	0.5	27.4	50
2EZ39D5	39	12.8	30.0	1000	0.25	0.5	29.7	47
2EZ43D5	43	11.6	35.0	1500	0.25	0.5	32.7	43
2EZ47D5	47	10.6	40.0	1500	0.25	0.5	35.8	39
2EZ51D5	51	9.8	48.0	1500	0.25	0.5	38.8	36
2EZ56D5	56	9.0	55.0	2000	0.25	0.5	42.6	32
2EZ62D5	62	8.1	60.0	2000	0.25	0.5	47.1	29
2EZ68D5	68	7.4	75.0	2000	0.25	0.5	51.7	27
2EZ75D5	75	6.7	90.0	2000	0.25	0.5	56.0	24
2EZ82D5	82	6.1	100.0	3000	0.25	0.5	62.2	22

- Note: 1. Type numbers listed have standard tolerance on the nominal zener voltage of ±5%.
 2. Measured under thermal equilibrium and DC (I_{ZT}) test conditions.
 3. The Zener impedance is derived from the 60Hz AC voltage which results when an AC current having an RMS value equal to 10% of the Zener current (I_{ZT} or I_{ZK}) is superimposed on I_{ZT} or I_{ZK}. Zener impedance is measured at two points to insure a sharp knee on the breakdown curve and to eliminate unstable units.

Electrical Characteristics (@T_A=25°C unless otherwise specified) Table 1 (Cont'd)

Type Number (Note 1)	Nominal Zener Voltage (Note 2)	Test Current	Maximum Zener Impedance (Note 3)			Maximum Leakage Current		Max DC Zener Current
	V _Z @ I _{ZT}	I _{ZT}	Z _{ZT} @ I _{ZT}	Z _{ZK} @ I _{ZK}	I _{ZK}	I _R @ V _R		I _{ZM}
	(V)	(mA)	()	()	(mA)	(μA)	(V)	(mA)
2EZ91D5	91	5.5	125.0	3000	0.25	0.5	69.2	20
2EZ100D5	100	5.0	175.0	3000	0.25	0.5	76.0	18
2EZ110D5	110	4.5	250.0	4000	0.25	0.5	83.6	17
2EZ120D5	120	4.2	325.0	4500	0.25	0.5	91.2	15
2EZ130D5	130	3.8	400.0	5000	0.25	0.5	98.8	14
2EZ140D5	140	3.6	500.0	5500	0.25	0.5	106.4	13
2EZ150D5	150	3.3	575.0	6000	0.25	0.5	114.0	12
2EZ160D5	160	3.1	650.0	6500	0.25	0.5	121.6	11
2EZ170D5	170	2.9	675.0	7000	0.25	0.5	130.4	11
2EZ180D5	180	2.8	725.0	7000	0.25	0.5	136.8	10
2EZ190D5	190	2.6	825.0	8000	0.25	0.5	144.8	10
2EZ200D5	200	2.5	900.0	8000	0.25	0.5	152.0	9.0
2EZ220D5	220	2.0	2000.0	8500	0.25	0.5	167.0	8.0
2EZ270D5	270	1.6	2200.0	8500	0.25	0.5	205.0	6.7
2EZ300D5	300	1.5	2200.0	9000	0.25	0.5	228.0	5.9
2EZ330D5	330	1.4	2300.0	9000	0.25	0.5	250.0	5.4

- Note:
1. Type numbers listed have standard tolerance on the nominal zener voltage of ±5%.
 2. Measured under thermal equilibrium and DC (I_{ZT}) test conditions.
 3. The Zener impedance is derived from the 60Hz AC voltage which results when an AC current having an RMS value equal to 10% of the Zener current (I_{ZT} or I_{ZK}) is superimposed on I_{ZT} or I_{ZK}. Zener impedance is measured at two points to insure a sharp knee on the breakdown curve and to eliminate unstable units.

MARKING INFORMATION

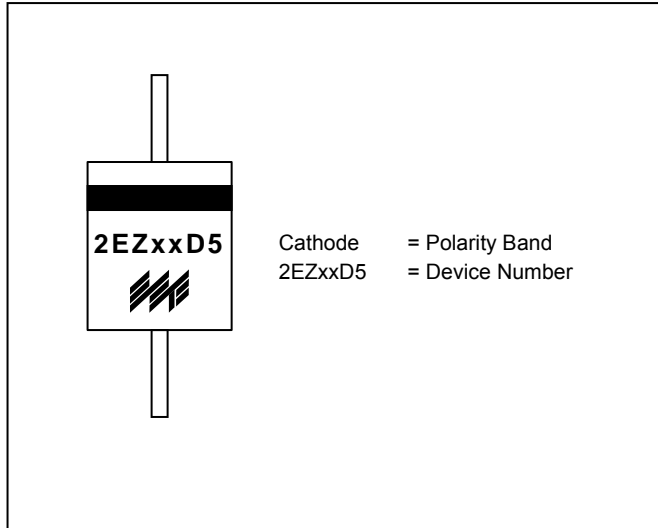

TAPING SPECIFICATIONS

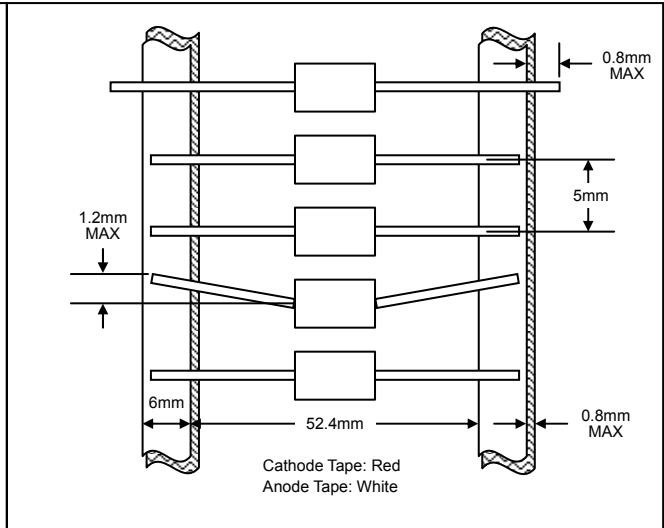

PACKAGING INFORMATION

TAPE & REEL

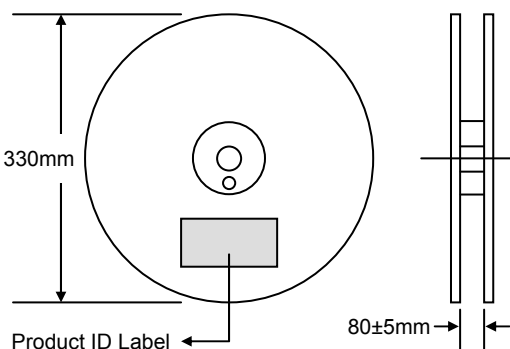

330mm

Product ID Label

80±5mm

TAPE & BOX

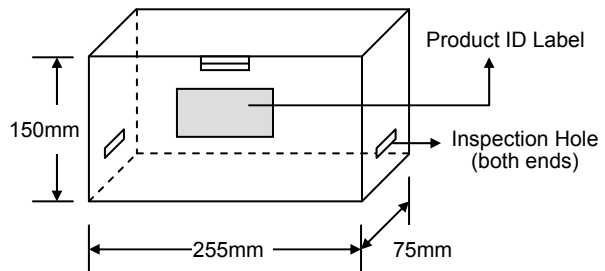

150mm

255mm

75mm

Product ID Label

Inspection Hole (both ends)

BULK

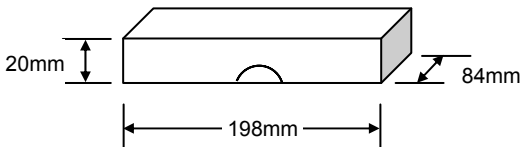

20mm

198mm

84mm

Packaging	Reel Diameter / Box Size (mm)	Quantity (PCS)	Carton Size (mm)	Quantity (PCS)	Approx. Gross Weight (KG)
TAPE & REEL	330	5,000	370 x 370 x 420	25,000	13.0
TAPE & BOX	255 x 75 x 150	5,000	400 x 273 x 415	50,000	21.0
BULK	198 x 84 x 20	1,000	459 x 214 x 256	50,000	19.5

Note: 1. Paper reel, white or gray color. Core material: plastic or metal.
2. Components are packed in accordance with EIA standard RS-296-E.

ORDERING INFORMATION

Product No.	Package Type	Shipping Quantity
2EZxxD5-T3	DO-41	5000/Tape & Reel
2EZxxD5-TB	DO-41	5000/Tape & Box
2EZxxD5	DO-41	1000 Units/Box

1. Products listed in **bold** are WTE **Preferred** Devices.
2. Shipping quantity given is for minimum packing quantity only. For minimum order quantity, please consult the Sales Department.
3. **To order RoHS / Lead Free version (with Lead Free finish), add "-LF" suffix to part number above. For example, 2EZ2.7D5-TB-LF.**

WON-TOP ELECTRONICS and  are registered trademarks of Won-Top Electronics Co., Ltd (WTE). WTE has checked all information carefully and believes it to be correct and accurate. However, WTE cannot assume any responsibility for inaccuracies. Furthermore, this information does not give the purchaser of semiconductor devices any license under patent rights to manufacturer. WTE reserves the right to change any or all information herein without further notice.

WARNING: DO NOT USE IN LIFE SUPPORT EQUIPMENT. WTE power semiconductor products are not authorized for use as critical components in life support devices or systems without the express written approval.

Won-Top Electronics Co., Ltd.
No. 44 Yu Kang North 3rd Road,
Chine Chen Dist., Kaohsiung 806, Taiwan
Phone: 886-7-822-5408 or 886-7-822-5410
Fax: 886-7-822-5417
Email: sales@wontop.com
Internet: <http://www.wontop.com>

We power your everyday.