EF1605FCT THRU EF1660FCT

List

List.....	1
Package outline.....	2
Features.....	2
Mechanical data.....	2
Maximum ratings	2
Rating and characteristic curves.....	3
Pinning information.....	4
Marking.....	4
Tube packing.....	4
Suggested thermal profiles for soldering processes.....	5
High reliability test capabilities.....	6

EF1605FCT THRU EF1660FCT

16.0A Glass Passivated Efficient Fast Rectifiers-50-600V

Features

- Reverse recovery time less than 25ns
- Dual rectifier construction, positive centetap, offers 8.0A half wave and 16.0A full wave rectification.
- High current capability.
- Low reverse leakage current.
- High surge capability.
- Glass passivated chip junction.
- Low forward drop down voltage.
- High reliability.
- Lead-free parts meet RoHS requirements.
- Suffix "-H" indicates Halogen free parts, ex. EF1605FCT-H.

Mechanical data

- Epoxy : UL94-V0 rated flame retardant
- Case : JEDEC ITO-220AB molded plastic body over passivated chip
- Lead : Axial leads, solderable per MIL-STD-202, Method 208 guaranteed
- Polarity: As marked
- Mounting Position : Any
- Weight : Approximated 1.70 gram

Package outline

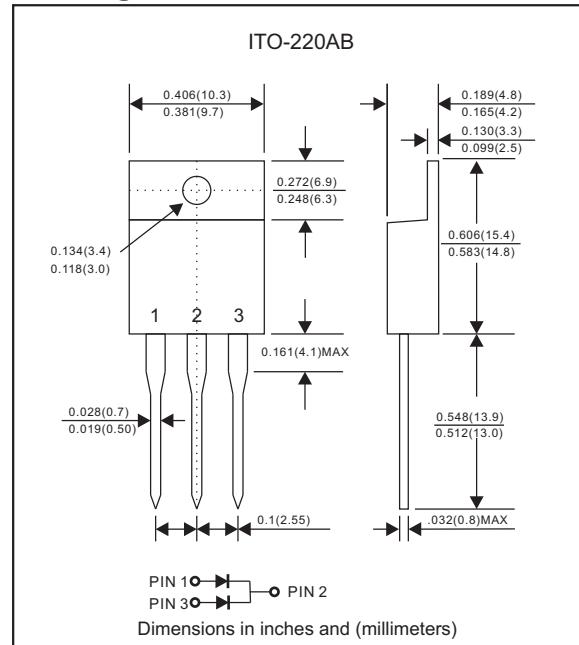

Maximum ratings (AT $T_A=25^{\circ}\text{C}$ unless otherwise noted)

PARAMETER	SYMBOLS	EF1605FCT	EF1610FCT	EF1620FCT	EF1640FCT	EF1660FCT	UNIT
Maximum repetitive peak reverse voltage	V_{RRM}	50	100	200	400	600	V
Maximum RMS voltage	V_{RMS}	35	70	140	280	420	V
Maximum DC blocking voltage	V_{DC}	50	100	200	400	600	V
Maximum average forward rectified current	I_o	16.0					A
Peak forward surge current 8.3ms single half sine-wave(JEDEC method)	I_{FSM}	100					A
Typical diode junction capacitance (Note 1)	C_J	30					pF
Operating junction temperature range	T_J	-55 to +150					$^{\circ}\text{C}$
Storage temperature range	T_{STG}	-65 to +175					$^{\circ}\text{C}$

Electrical characteristics (AT $T_A=25^{\circ}\text{C}$ unless otherwise noted)

PARAMETER	SYMBOLS	EF1605FCT	EF1610FCT	EF1620FCT	EF1640FCT	EF1660FCT	UNIT
Maximum forward voltage per leg at $I_F=8.0A$	V_F	0.98			1.30	1.75	V
Maximum DC reverse current at rated DC blocking voltage per leg	I_R	5.0 250					μA μA
Maximum reverse recovery time per leg (Note 2)	t_{rr}	25					ns

Thermal characteristics

PARAMETER	SYMBOLS	EF1605FCT	EF1610FCT	EF1620FCT	EF1640FCT	EF1660FCT	UNIT
Typical thermal resistance junction to case per leg	$R_{\theta JC}$	2.5					$^{\circ}\text{C}/\text{W}$

Note 1: Measure at 1 MHz and applied reverse voltage of 4.0 V D.C.
 Note 2: Reverse recovery time test condition, $I_F=0.5A$, $I_R=1.0A$, $I_{RR}=0.25A$

Rating and characteristic curves (EF1605FCT THRU EF1660FCT)

FIG.1-TYPICAL FORWARD CURRENT DERATING CURVE

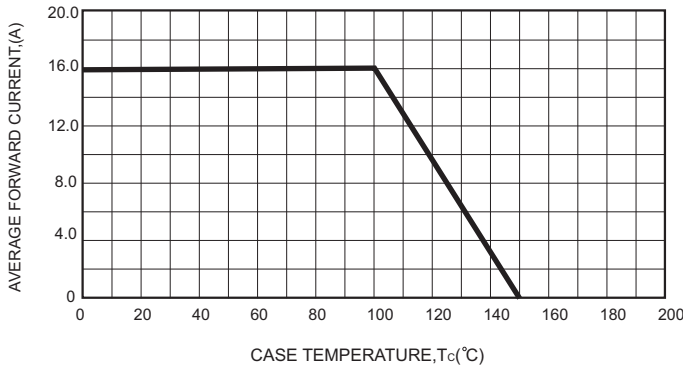

FIG.2-MAXIMUM NON-REPETITIVE FORWARD SURGE CURRENT

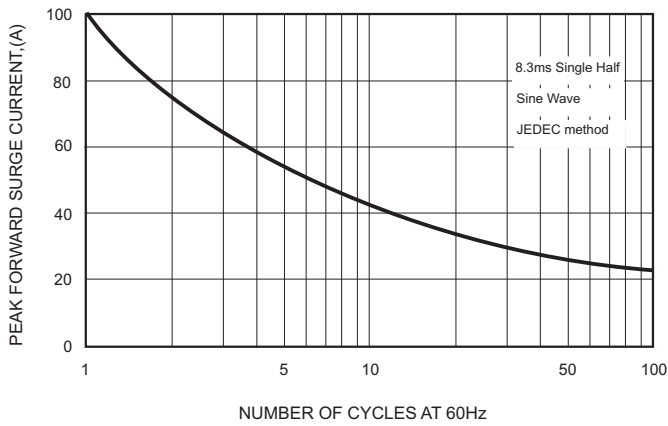

FIG.3-TYPICAL FORWARD CHARACTERISTICS

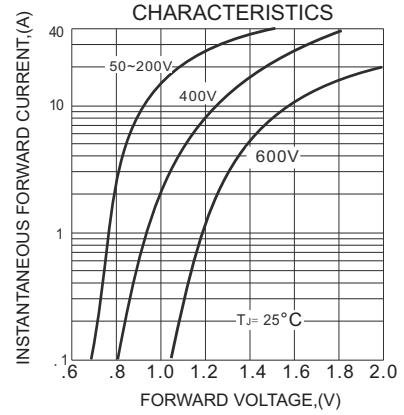

FIG.4 - TYPICAL REVERSE CHARACTERISTICS

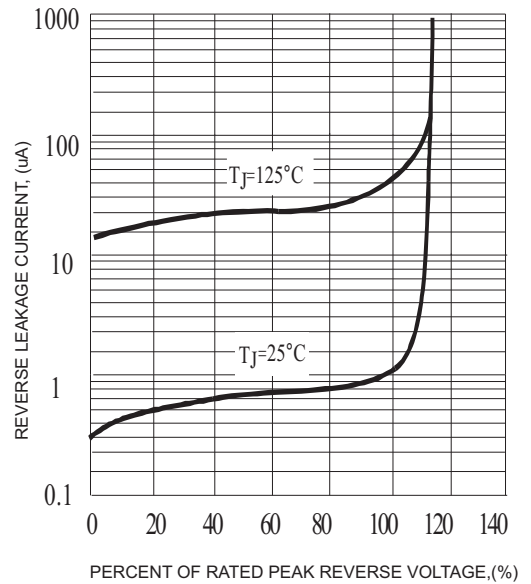
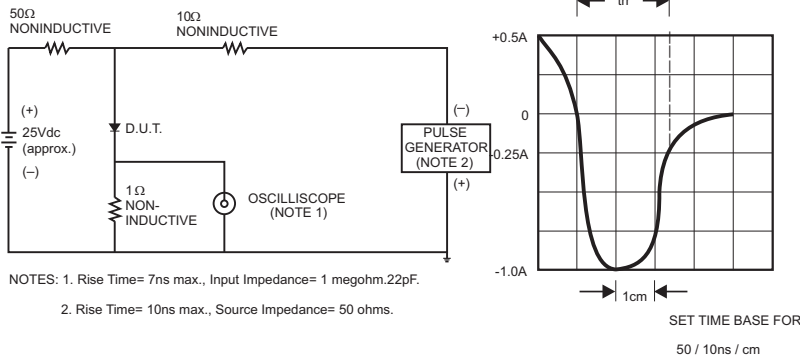

FIG.5- TEST CIRCUIT DIAGRAM AND REVERSE RECOVERY TIME CHARACTERISTICS



NOTES: 1. Rise Time= 7ns max., Input Impedance= 1 megohm.22pF.
2. Rise Time= 10ns max., Source Impedance= 50 ohms.

EF1605FCT THRU EF1660FCT

Pinning information

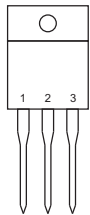
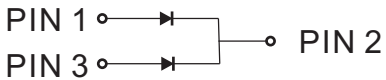
Pin	Simplified outline	Symbol
Pin1 anode Pin2 cathode Pin3 anode		

Marking

Type number	Marking code
EF1605FCT	EF1605FCT
EF1610FCT	EF1610FCT
EF1620FCT	EF1620FCT
EF1640FCT	EF1640FCT
EF1660FCT	EF1660FCT

Tube packing

PACKAGE	TUBE (pcs)	TUBE SIZE (m/m)	BOX (pcs)	INNER BOX (m/m)	CARTON SIZE (m/m)	CARTON (pcs)	APPROX. GROSS WEIGHT (kg)
ITO-220AB	50	525*32*7.0	1000	555*150*40	580*230*175	5,000	15.0

EF1605FCT THRU EF1660FCT

Suggested thermal profiles for soldering processes

1. Lead free temperature profile wave-soldering

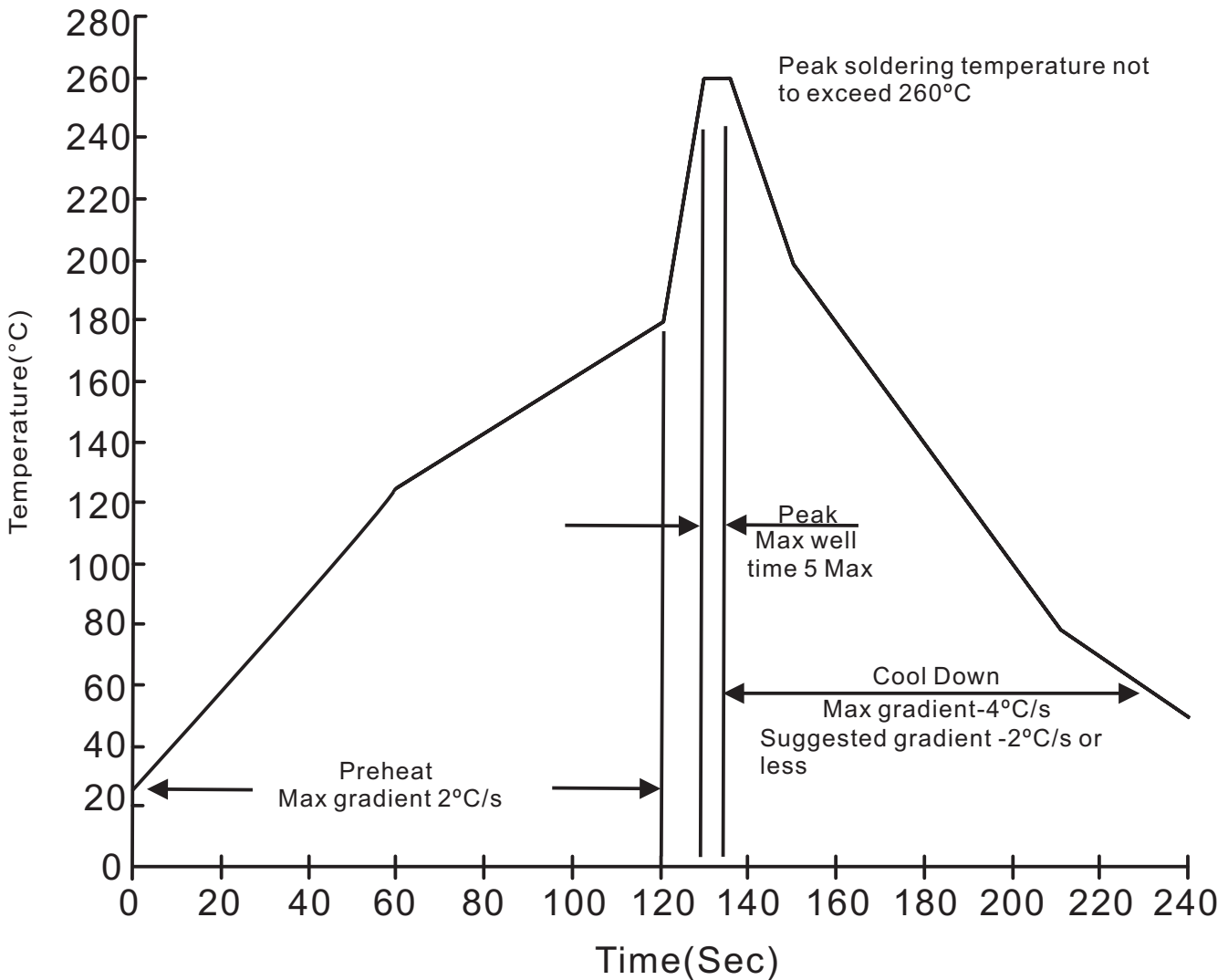

EF1605FCT THRU EF1660FCT

High reliability test capabilities

Item Test	Conditions	Reference
1. Solder Resistance	at $260\pm 5^{\circ}\text{C}$ for $10\pm 2\text{sec}$. immerse body into solder $1/16''\pm 1/32''$	MIL-STD-750D METHOD-2031
2. Solderability	at $245\pm 5^{\circ}\text{C}$ for 5 sec.	MIL-STD-202F METHOD-208
3. High Temperature Reverse Bias	$V_R=80\%$ rate at $T_J=150^{\circ}\text{C}$ for 168 hrs.	MIL-STD-750D METHOD-1038
4. Forward Operation Life	Rated average rectifier current at $T_A=25^{\circ}\text{C}$ for 500hrs.	MIL-STD-750D METHOD-1027
5. Intermittent Operation Life	$T_A = 25^{\circ}\text{C}$, $I_F = I_o$ On state: power on for 5 min. off state: power off for 5 min. on and off for 500 cycles.	MIL-STD-750D METHOD-1036
6. Pressure Cooker	$15P_{SIG}$ at $T_A=121^{\circ}\text{C}$ for 4 hrs.	JESD22-A102
7. Temperature Cycling	-55°C to $+125^{\circ}\text{C}$ dwelled for 30 min. and transferred for 5min. total 10 cycles.	MIL-STD-750D METHOD-1051
8. Forward Surge	8.3ms single half sine-wave , one surge.	MIL-STD-750D METHOD-4066-2
9. Humidity	at $T_A=85^{\circ}\text{C}$, RH=85% for 1000hrs.	MIL-STD-750D METHOD-1021
10. High Temperature Storage Life	at 175°C for 1000 hrs.	MIL-STD-750D METHOD-1031