

Features

- **Low Voltage and Standard Voltage Operation**
 - 5.0 (Vcc = 4.5V to 5.5V)
 - 2.7 (Vcc = 2.7V to 5.5V)
 - 2.5 (Vcc = 2.5V to 5.5V)
 - 1.8 (Vcc = 1.8V to 5.5V)
- **User Selectable Internal Organization**
 - 1K: 128 x 8 or 64 x 16
 - 2K: 256 x 8 or 128 x 16
 - 4K: 512 x 8 or 256 x 16
- **4-Wire Serial Interface**
- **Self-Timed Write Cycle (10 ms max)**
- **High Reliability**
 - Endurance: 1 Million Cycles
 - Data Retention: 100 Years
- **8-Pin PDIP and EIAJ SOIC Packages**

Description

The AT59C11/22/13 provides 1024/2048/4096 bits of serial EEPROM (Electrically Erasable Programmable Read Only Memory) organized as 64/128/256 words of 16 bits each, when the ORG Pin is connected to Vcc and 128/256/512 words of 8 bits each when it is tied to ground. The device is optimized for use in many industrial and commercial applications where low power and low voltage operation are essential. The AT59C11/22/13 is available in space saving 8-pin PDIP and 8-pin EIAJ SOIC packages.

The AT59C11/22/13 is enabled through the Chip Select pin (CS), and accessed via a 4-wire serial interface consisting of Data Input (DI), Data Output (DO), and Clock (CLK). Upon receiving a READ instruction at DI, the address is decoded and the data

(continued)

**4-Wire
Serial CMOS
E²PROMs**

1K (128 x 8 or 64 x 16)

2K (256 x 8 or 128 x 16)

4K (512 x 8 or 256 x 16)

Pin Configurations

Pin Name	Function
CS	Chip Select
CLK	Serial Data Clock
DI	Serial Data Input
DO	Serial Data Output
GND	Ground
Vcc	Power Supply
ORG	Internal Organization
RDY/BUSY	Status Output

8-Pin PDIP

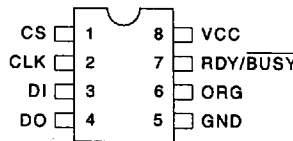

8-Pin SOIC

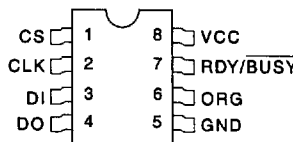



Description (Continued)

is clocked out serially on the data output pin DO, the WRITE cycle is completely self-timed and no separate ERASE cycle is required before WRITE. The WRITE cycle is only enabled when the part is in the ERASE/WRITE ENABLE state. Ready/Busy status can be monitored upon

completion of a programming operation by polling the Ready/Busy pin.

The AT59C11/22/13 is available in 5.0V \pm 10%, 2.7V to 5.5V, 2.5V to 5.5V, and 1.8V to 5.5V versions.

Absolute Maximum Ratings*

Operating Temperature.....	-55°C to +125°C
Storage Temperature.....	-65°C to +150°C
Voltage on Any Pin with Respect to Ground	-1.0V to +7.0V
Maximum Operating Voltage	6.25V
DC Output Current.....	5.0 mA

*NOTICE: Stresses beyond those listed under "Absolute Maximum Ratings" may cause permanent damage to the device. This is a stress rating only and functional operation of the device at these or any other conditions beyond those indicated in the operational sections of this specification is not implied. Exposure to absolute maximum rating conditions for extended periods may affect device reliability.

Block Diagram ⁽¹⁾

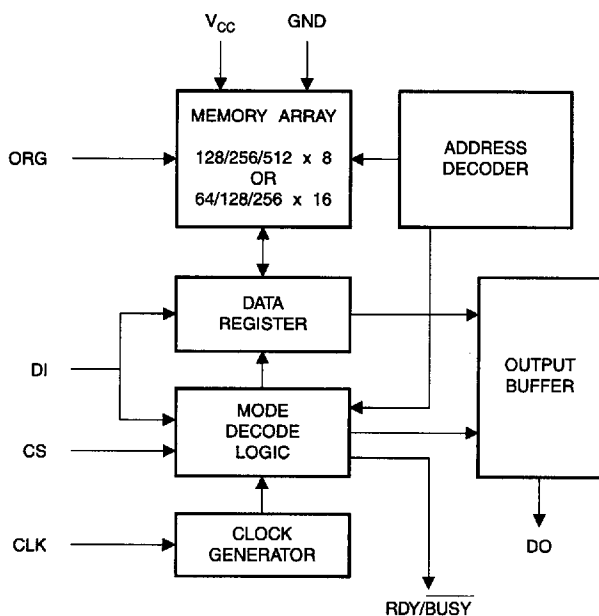

Note: 1. When the ORG pin is connected to VCC, the x 16 organization is selected. When it is connected to ground, the x 8 organization is selected. If the ORG pin is left unconnected, then an internal pullup device will select the x 16 organization. This feature is not available on 1.8V devices.

Pin Capacitance ⁽¹⁾

Applicable over recommended operating range from $T_A = 25^\circ\text{C}$, $f = 1.0\text{ MHz}$, $V_{CC} = +5.0\text{V}$ (unless otherwise noted).

Test Conditions		Max	Units	Conditions
C_{OUT}	Output Capacitance (DO)	5	pF	$V_{OUT} = 0\text{V}$
C_{IN}	Input Capacitance (CS, CLK, DI, RDY/BUSY)	5	pF	$V_{IN} = 0\text{V}$

Note: 1. This parameter is characterized and is not 100% tested.

DC Characteristics

Applicable over recommended operating range from: $T_A = -40^\circ\text{C}$ to $+85^\circ\text{C}$, $V_{CC} = +1.8\text{V}$ to $+5.5\text{V}$, $T_{AC} = 0^\circ\text{C}$ to $+70^\circ\text{C}$, $V_{CC} = +1.8\text{V}$ to $+5.5\text{V}$ (unless otherwise noted).

Symbol	Parameter	Test Condition	Min	Typ	Max	Units
V_{CC1}	Supply Voltage		1.8		5.5	V
V_{CC2}	Supply Voltage		2.5		5.5	V
V_{CC3}	Supply Voltage		2.7		5.5	V
V_{CC4}	Supply Voltage		4.5		5.5	V
I_{CC}	Supply Current	$V_{CC} = 5.0\text{V}$	READ at 1.0 MHz	0.5	2.0	mA
			WRITE at 1.0 MHz	0.5	2.0	mA
I_{SB1}	Standby Current	$V_{CC} = 1.8\text{V}$ CS = 0V	0.0	0.1		μA
I_{SB2}	Standby Current	$V_{CC} = 2.5\text{V}$ CS = 0V	6.0	10.0		μA
I_{SB3}	Standby Current	$V_{CC} = 2.7\text{V}$ CS = 0V	6.0	10.0		μA
I_{SB4}	Standby Current	$V_{CC} = 5.0\text{V}$ CS = 0V	21.0	30.0		μA
I_{IL}	Input Leakage	$V_{IN} = 0\text{V}$ to V_{CC}		0.1	1.0	μA
I_{OL}	Output Leakage	$V_{IN} = 0\text{V}$ to V_{CC}		0.1	1.0	μA
$V_{IL1}^{(1)}$	Input Low Voltage	$4.5\text{V} \leq V_{CC} \leq 5.5\text{V}$	-0.1		0.8	V
$V_{IH1}^{(1)}$	Input High Voltage	$\leq 5.5\text{V}$	2.0		$V_{CC} + 1$	V
$V_{IL2}^{(1)}$	Input Low Voltage	$1.8\text{V} \leq V_{CC} \leq 2.7\text{V}$	0.0		$V_{CC} \times 0.3$	V
$V_{IH2}^{(1)}$	Input High Voltage	$\leq 2.7\text{V}$	$V_{CC} \times 0.7$		$V_{CC} + 1$	V
V_{OL1}	Output Low Voltage	$4.5\text{V} \leq V_{CC} \leq 5.5\text{V}$			0.4	V
V_{OH1}	Output High Voltage	$\leq 5.5\text{V}$	$I_{OL} = 2.1\text{ mA}$ $I_{OH} = 0.4\text{ mA}$	2.4		V
V_{OL2}	Output Low Voltage	$1.8\text{V} \leq V_{CC} \leq 2.7\text{V}$			0.2	V
V_{OH2}	Output High Voltage	$\leq 2.7\text{V}$	$I_{OL} = 0.15\text{ mA}$ $I_{OH} = -0.1\text{ mA}$	$V_{CC} - 0.2$		V

Note: 1. V_{IL} min and V_{IH} max are reference only and are not tested.





AC Characteristics

Applicable over recommended operating range from $T_A = -40^{\circ}\text{C}$ to $+85^{\circ}\text{C}$, $V_{CC} = +1.8\text{V}$ to $+5.5\text{V}$, $CL = 1$ TTL Gate and 100 pF (unless otherwise noted).

Symbol	Parameter	Test Condition	Min	Typ	Max	Units
f _{CLK}	CLK Clock Frequency	$4.5\text{V} \leq V_{CC} \leq 5.5\text{V}$	0		1	MHz
		$2.7\text{V} \leq V_{CC} \leq 5.5\text{V}$	0		1	
		$2.5\text{V} \leq V_{CC} \leq 5.5\text{V}$	0		0.5	
		$1.8\text{V} \leq V_{CC} \leq 5.5\text{V}$	0		0.25	
t _{CKH}	CLK High Time	$4.5\text{V} \leq V_{CC} \leq 5.5\text{V}$	250			ns
		$2.7\text{V} \leq V_{CC} \leq 5.5\text{V}$	250			
		$2.5\text{V} \leq V_{CC} \leq 5.5\text{V}$	500			
		$1.8\text{V} \leq V_{CC} \leq 5.5\text{V}$	1000			
t _{CKL}	CLK Low Time	$4.5\text{V} \leq V_{CC} \leq 5.5\text{V}$	250			ns
		$2.7\text{V} \leq V_{CC} \leq 5.5\text{V}$	250			
		$2.5\text{V} \leq V_{CC} \leq 5.5\text{V}$	500			
		$1.8\text{V} \leq V_{CC} \leq 5.5\text{V}$	1000			
t _{CS}	Minimum CS Low Time	$4.5\text{V} \leq V_{CC} \leq 5.5\text{V}$	250			ns
		$2.7\text{V} \leq V_{CC} \leq 5.5\text{V}$	250			
		$2.5\text{V} \leq V_{CC} \leq 5.5\text{V}$	500			
		$1.8\text{V} \leq V_{CC} \leq 5.5\text{V}$	1000			
t _{CSS}	CS Setup Time	Relative to SK				ns
		$4.5\text{V} \leq V_{CC} \leq 5.5\text{V}$	50			
		$2.7\text{V} \leq V_{CC} \leq 5.5\text{V}$	50			
		$2.5\text{V} \leq V_{CC} \leq 5.5\text{V}$	100			
t _{DIS}	DI Setup Time	Relative to SK				ns
		$4.5\text{V} \leq V_{CC} \leq 5.5\text{V}$	100			
		$2.7\text{V} \leq V_{CC} \leq 5.5\text{V}$	100			
		$2.5\text{V} \leq V_{CC} \leq 5.5\text{V}$	200			
t _{CSH}	CS Hold Time	Relative to SK				ns
		$4.5\text{V} \leq V_{CC} \leq 5.5\text{V}$	0			
		$2.7\text{V} \leq V_{CC} \leq 5.5\text{V}$	100			
		$2.5\text{V} \leq V_{CC} \leq 5.5\text{V}$	200			
t _{DIH}	DI Hold Time	Relative to SK				ns
		$4.5\text{V} \leq V_{CC} \leq 5.5\text{V}$	100			
		$2.7\text{V} \leq V_{CC} \leq 5.5\text{V}$	100			
		$2.5\text{V} \leq V_{CC} \leq 5.5\text{V}$	200			
t _{PD1}	Output Delay to '1'	AC Test				ns
		$4.5\text{V} \leq V_{CC} \leq 5.5\text{V}$			250	
		$2.7\text{V} \leq V_{CC} \leq 5.5\text{V}$			250	
		$2.5\text{V} \leq V_{CC} \leq 5.5\text{V}$			500	
t _{PD0}	Output Delay to '0'	AC Test				ns
		$4.5\text{V} \leq V_{CC} \leq 5.5\text{V}$			250	
		$2.7\text{V} \leq V_{CC} \leq 5.5\text{V}$			250	
		$2.5\text{V} \leq V_{CC} \leq 5.5\text{V}$			500	
t _{ABD}	CS to Status Valid	AC Test				ns
		$4.5\text{V} \leq V_{CC} \leq 5.5\text{V}$			250	
		$2.7\text{V} \leq V_{CC} \leq 5.5\text{V}$			250	
		$2.5\text{V} \leq V_{CC} \leq 5.5\text{V}$			500	
t _{cz}	CS to DO in High Impedance	AC Test				ns
		CS = V _{IL}				
		$4.5\text{V} \leq V_{CC} \leq 5.5\text{V}$			100	
		$2.7\text{V} \leq V_{CC} \leq 5.5\text{V}$			100	
t _{wc}	Write Cycle Time					ms
		$2.5\text{V} \leq V_{CC} \leq 5.5\text{V}$			200	
		$1.8\text{V} \leq V_{CC} \leq 5.5\text{V}$			400	
			0.1		10	

Instruction Set for the AT59C11

Instruction	SB	Op Code	Address		Data		Comments
			x 8	x 16	x 8	x 16	
READ	1	10XX	A ₆ - A ₀	A ₅ - A ₀			Reads data stored in memory, at specified address.
EWEN	1	0011	XXXXXXXX	XXXXXX			Write enable must precede all programming modes.
WRITE	1	X1XX	A ₆ - A ₀	A ₅ - A ₀	D ₇ - D ₀	D ₁₅ - D ₀	Writes memory location A _n - A ₀ .
ERAL	1	0010	XXXXXXXX	XXXXXX			Erases all memory locations. Valid only at V _{CC} = 4.5V to 5.5V.
WRAL	1	0001	XXXXXXXX	XXXXXX	D ₇ - D ₀	D ₁₅ - D ₀	Writes all memory locations. Valid only at V _{CC} = 4.5V to 5.5V.
EWDS	1	0000	XXXXXXXX	XXXXXX			Disables all programming instructions.

2

Instruction Set for the AT59C22

Instruction	SB	Op Code	Address		Data		Comments
			x 8	x 16	x 8	x 16	
READ	1	10XX	A ₇ - A ₀	A ₆ - A ₀			Reads data stored in memory, at specified address.
EWEN	1	0011	XXXXXXXX	XXXXXXXX			Write enable must precede all programming modes.
WRITE	1	X1XX	A ₇ - A ₀	A ₆ - A ₀	D ₇ - D ₀	D ₁₅ - D ₀	Writes memory location A _n - A ₀ .
ERAL	1	0010	XXXXXXXX	XXXXXXXX			Erases all memory locations. Valid only at V _{CC} = 4.5V to 5.5V.
WRAL	1	0001	XXXXXXXX	XXXXXXXX	D ₇ - D ₀	D ₁₅ - D ₀	Writes all memory locations. Valid when V _{CC} = 5.0V ± 10% and Disable Register cleared.
EWDS	1	0000	XXXXXXXX	XXXXXXXX			Disables all programming instructions.





Instruction Set for the AT59C13

Instruction	SB	Op Code	Address		Data		Comments
			x 8	x 16	x 8	x 16	
READ	1	10XX	A ₈ - A ₀	A ₇ - A ₀			Reads data stored in memory, at specified address.
EWEN	1	0011	XXXXXXXX	XXXXXXXX			Write enable must precede all programming modes.
WRITE	1	X1XX	A ₈ - A ₀	A ₇ - A ₀	D ₇ - D ₀	D ₁₅ - D ₀	Writes memory location A _n - A ₀ .
ERAL	1	0010	XXXXXXXX	XXXXXXXX			Erases all memory locations. Valid only at V _{CC} = 4.5V to 5.5V.
WRAL	1	0001	XXXXXXXX	XXXXXXXX	D ₇ - D ₀	D ₁₅ - D ₀	Writes all memory locations. Valid when V _{CC} = 5.0V ± 10% and Disable Register cleared.
EWDS	1	0000	XXXXXXXX	XXXXXXXX			Disables all programming instructions.

Functional Description

The AT59C11/22/13 are accessed via a simple and versatile 4-wire serial communication interface. Device operation is controlled by six instructions issued by the host processor. A valid instruction starts with a rising edge of CS and consists of a Start Bit (logic '1') followed by the appropriate Op Code and the desired memory Address location.

READ (READ): The Read (READ) instruction contains the Address code for the memory location to be read. After the instruction and address are decoded, data from the selected memory location is available at the serial output pin DO. Output data changes are synchronized with the rising edges of serial clock CLK. It should be noted that a dummy bit (logic '0') precedes the 8 or 16 bit data output string.

ERASE/WRITE (EWEN): To assure data integrity, the part automatically goes into the Erase/Write Disable (EWDS) state when power is first applied. An Erase/Write Enable (EWEN) instruction must be executed first before any programming instructions can be carried out. Please note that once in the Erase/Write Enable state, programming remains enabled until an Erase/Write Disable (EWDS) instruction is executed or V_{CC} power is removed from the part.

WRITE (WRITE): The Write (WRITE) instruction contains the 8 or 16 bits of data to be written into the specified memory location. The self-timed programming cycle starts

after the last bit of data is received at serial data input pin DI. The Ready/Busy status of the AT59C11/22/13 can be determined by polling the RDY/BUSY pin. A logic '0' at RDY/BUSY indicates that programming is still in progress. A logic '1' indicates that the memory location at the specified address has been written with the data pattern contained in the instruction and the part is ready for further instructions.

ERASE ALL (ERAL): The Erase All (ERAL) instruction programs every bit in the memory array to the logic '1' state and is primarily used for testing purposes. The Ready/Busy status of the AT59C11/22/13 can be determined by polling the RDY/BUSY pin. The ERAL instruction is valid only at V_{CC} = 5.0V ± 10%.

WRITE ALL (WRAL): The Write All (WRAL) instruction programs all memory locations with the data patterns specified in the instruction. The Ready/Busy status of the AT59C11/22/13 can be determined by polling the RDY/BUSY pin. The WRAL instruction is valid only at V_{CC} = 5.0V ± 10%.

ERASE/WRITE DISABLE (EWDS): To protect against accidental data disturb, the Erase/Write Disable (EWDS) instruction disables all programming modes and should be executed after all programming operations. The operation of the READ instruction is independent of both the EWEN and EWDS instructions and can be executed at any time.

Timing Diagrams

Synchronous Data Timing

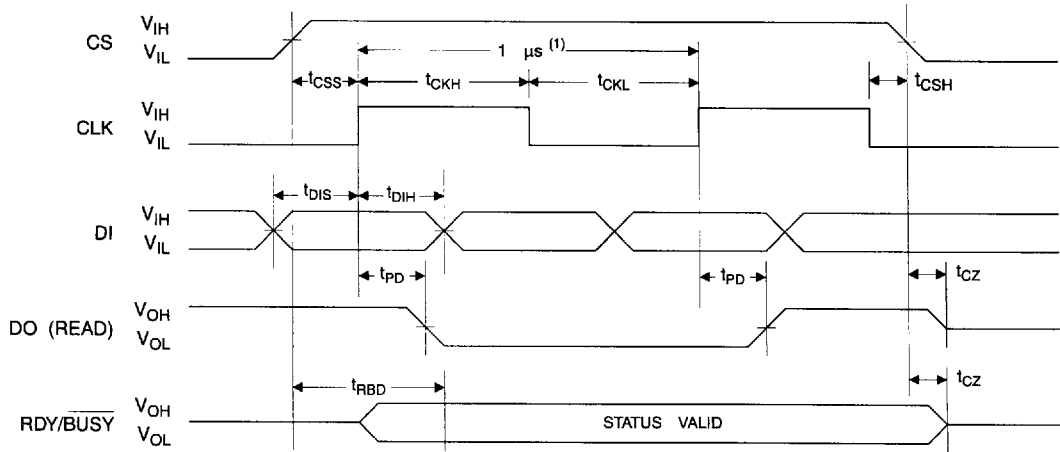

Note: 1. This is the minimum CLK period.

(continued)





Organization Key for Timing Diagrams

I/O	Density 1K		Density 2K		Density 4K	
	x 8	x 16	x 8	x 16	x 8	x 16
A _N	A ₆	A ₅	A ₇	A ₆	A ₈	A ₇
D _N	D ₇	D ₁₅	D ₇	D ₁₅	D ₇	D ₁₅

Timing Diagrams (Continued)

READ Timing

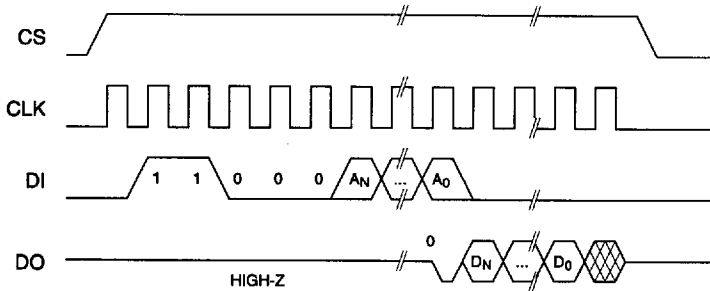

WRITE Timing

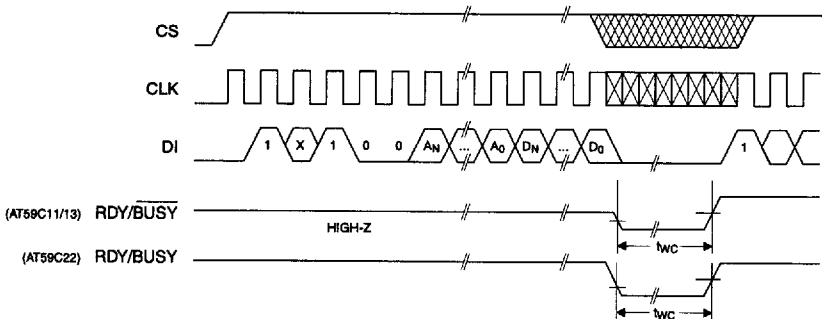

EWEN/EWDS Timing

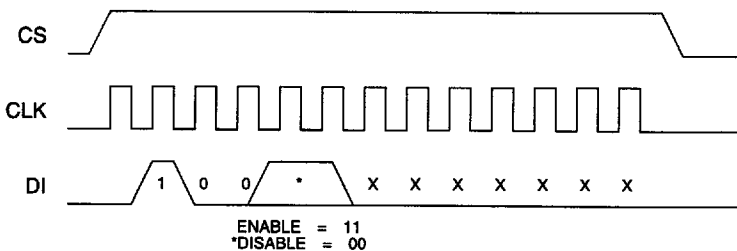

(continued)

Timing Diagrams (Continued)

ERAL Timing

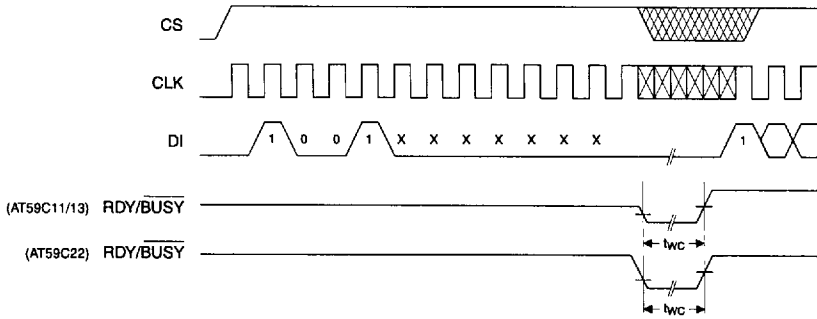

2

WRAL Timing

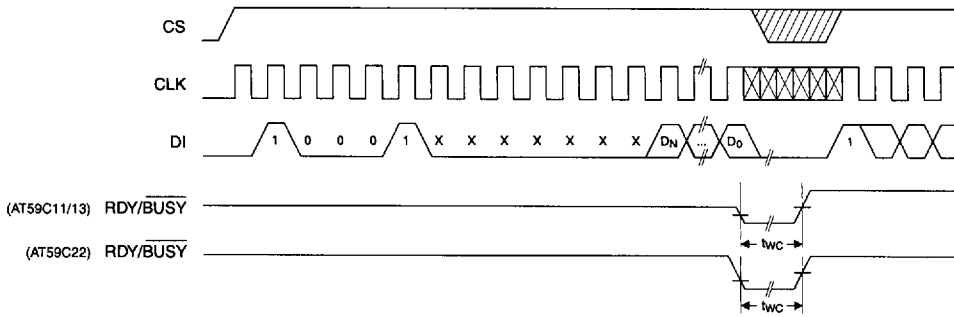



Ordering Information

twc (max) (ms)	icc (max) (μ A)	IsB (max) (μ A)	fMAX (kHz)	Ordering Code	Package	Operation Range
10	2000	30.0	1000	AT59C11-10PC AT59C11W-10SC	8P3 8S2	Commercial (0°C to 70°C)
10	800	10.0	1000	AT59C11-10PC-2.7 AT59C11W-10SC-2.7	8P3 8S2	Commercial (0°C to 70°C)
10	600	10.0	500	AT59C11-10PC-2.5 AT59C11W-10SC-2.5	8P3 8S2	Commercial (0°C to 70°C)
10	80	0.1	250	AT59C11-10PC-1.8 AT59C11W-10SC-1.8	8P3 8S2	Commercial (0°C to 70°C)
10	2000	30.0	1000	AT59C11-10PI AT59C11W-10SI	8P3 8S2	Industrial (-40°C to 85°C)
10	800	10.0	1000	AT59C11-10PI-2.7 AT59C11W-10SI-2.7	8P3 8S2	Industrial (-40°C to 85°C)
10	600	10.0	500	AT59C11-10PI-2.5 AT59C11W-10SI-2.5	8P3 8S2	Industrial (-40°C to 85°C)
10	80	0.1	250	AT59C11-10PI-1.8 AT59C11W-10SI-1.8	8P3 8S2	Industrial (-40°C to 85°C)

Package Type	
8P3	8 Lead, 0.300" Wide, Plastic Dual Inline Package (PDIP)
8S2	8 Lead, 0.200" Wide, Plastic Gull Wing Small Outline (EIAJ SOIC)
Options	
Blank	Standard Device (4.5V to 5.5V)
-2.7	Low Voltage (2.7V to 5.5V)
-2.5	Low Voltage (2.5V to 5.5V)
-1.8	Low Voltage (1.8V to 5.5V)

Ordering Information

twc (max) (ms)	lcc (max) (μ A)	lsb (max) (μ A)	fMAX (kHz)	Ordering Code	Package	Operation Range
10	2000	30.0	1000	AT59C22-10PC AT59C22W-10SC	8P3 8S2	Commercial (0°C to 70°C)
10	800	10.0	1000	AT59C22-10PC-2.7 AT59C22W-10SC-2.7	8P3 8S2	Commercial (0°C to 70°C)
10	600	10.0	500	AT59C22-10PC-2.5 AT59C22W-10SC-2.5	8P3 8S2	Commercial (0°C to 70°C)
10	80	0.1	250	AT59C22-10PC-1.8 AT59C22W-10SC-1.8	8P3 8S2	Commercial (0°C to 70°C)
10	2000	30.0	1000	AT59C22-10PI AT59C22W-10SI	8P3 8S2	Industrial (-40°C to 85°C)
10	800	10.0	1000	AT59C22-10PI-2.7 AT59C22W-10SI-2.7	8P3 8S2	Industrial (-40°C to 85°C)
10	600	10.0	500	AT59C22-10PI-2.5 AT59C22W-10SI-2.5	8P3 8S2	Industrial (-40°C to 85°C)
10	80	0.1	250	AT59C22-10PI-1.8 AT59C22W-10SI-1.8	8P3 8S2	Industrial (-40°C to 85°C)

2

Package Type

8P3	8 Lead, 0.300" Wide, Plastic Dual Inline Package (PDIP)
8S2	8 Lead, 0.200" Wide, Plastic Gull Wing Small Outline (EIAJ SOIC)

Options

Blank	Standard Device (4.5V to 5.5V)
-2.7	Low Voltage (2.7V to 5.5V)
-2.5	Low Voltage (2.5V to 5.5V)
-1.8	Low Voltage (1.8V to 5.5V)





Ordering Information

t _{wc} (max) (ms)	I _{cc} (max) (μ A)	I _{sb} (max) (μ A)	f _{MAX} (kHz)	Ordering Code	Package	Operation Range
10	2000	30.0	1000	AT59C13-10PC AT59C13W-10SC	8P3 8S2	Commercial (0°C to 70°C)
10	800	10.0	1000	AT59C13-10PC-2.7 AT59C13W-10SC-2.7	8P3 8S2	Commercial (0°C to 70°C)
10	600	10.0	500	AT59C13-10PC-2.5 AT59C13W-10SC-2.5	8P3 8S2	Commercial (0°C to 70°C)
10	80	0.1	250	AT59C13-10PC-1.8 AT59C13W-10SC-1.8	8P3 8S2	Commercial (0°C to 70°C)
10	2000	30.0	1000	AT59C13-10PI AT59C13W-10SI	8P3 8S2	Industrial (-40°C to 85°C)
10	800	10.0	1000	AT59C13-10PI-2.7 AT59C13W-10SI-2.7	8P3 8S2	Industrial (-40°C to 85°C)
10	600	10.0	500	AT59C13-10PI-2.5 AT59C13W-10SI-2.5	8P3 8S2	Industrial (-40°C to 85°C)
10	80	0.1	250	AT59C13-10PI-1.8 AT59C13W-10SI-1.8	8P3 8S2	Industrial (-40°C to 85°C)

Package Type

8P3	8 Lead, 0.300" Wide, Plastic Dual Inline Package (PDIP)
8S2	8 Lead, 0.200" Wide, Plastic Gull Wing Small Outline (EIAJ SOIC)

Options

Blank	Standard Device (4.5V to 5.5V)
-2.7	Low Voltage (2.7V to 5.5V)
-2.5	Low Voltage (2.5V to 5.5V)
-1.8	Low Voltage (1.8V to 5.5V)