

1-102155-0 ✓ ACTIVE

[AMP-LATCH](#) | [AMP-LATCH Universal Headers](#)

TE Internal #: 1-102155-0

Ribbon Cable Connectors, Board-to-Board, 50 Position, 2.54 mm [.1 in] Centerline, Vertical, Through Hole - Solder, 2 Row, AMP-LATCH Universal Headers

[View on TE.com >](#)



[Connectors](#) > [PCB Connectors](#) > [Wire-to-Board Connectors](#) > [FFC, FPC & Ribbon Connectors](#) > [Ribbon Cable Connectors](#) >

[AMP-LATCH UNIVERSAL HEADERS](#)



Connector System: **Board-to-Board**

Number of Positions: **50**

Centerline (Pitch): **2.54 mm [.1 in]**

PCB Mount Retention: **With**

PCB Mount Retention Type: **Screw Mount**

[All AMP-LATCH UNIVERSAL HEADERS \(525\)](#)

Features

Product Type Features

Ribbon Cable Connector Header Type	Universal Ejection Pin Headers
Connector Product Type	Connector Assembly
Connector System	Board-to-Board
Connector & Housing Type	Receptacle
Connector & Contact Terminates To	Printed Circuit Board

Configuration Features

Number of Positions	50
PCB Mount Orientation	Vertical
Number of Rows	2

Electrical Characteristics

Insulation Resistance	5000 MΩ
Operating Voltage	250 VAC

Body Features

Daisy Chain	Without
Primary Product Color	Black
Connector Profile	Standard



Contact Features

Mating Square Post Dimension	.64 mm[.025 in]
PCB Contact Termination Area Plating Material Thickness	2.54 μ m[100 μ in]
Contact Type	Pin
	15 μ in
Contact Mating Area Plating Material	Gold, Gold Flash, Gold Flash over Palladium Nickel
Contact Shape & Form	Square
Contact Underplating Material	Nickel
PCB Contact Termination Area Plating Material	Tin-Lead
Contact Base Material	Brass, Phosphor Bronze
Contact Current Rating (Max)	1 A

Termination Features

Round Termination Post & Tail Diameter	.64 mm[.025 in]
Termination Post & Tail Length	3.94 mm[.155 in]
Termination Method to Printed Circuit Board	Through Hole - Solder

Mechanical Attachment

Mating Alignment	With
PCB Mount Alignment	With
Panel Mount Feature	Without
PCB Mount Retention	With
PCB Mount Retention Type	Screw Mount
Mating Alignment Type	Center, Dual Polarizing Bar
Mating Retention	Without
Connector Mounting Type	Board Mount

Housing Features

Housing Material	Thermoplastic
Centerline (Pitch)	2.54 mm[.1 in]

Dimensions

Shrouded End Dimension	3.81 mm[.15 in]
Connector Height	13.94 mm[.55 in]
PCB Thickness (Recommended)	3.18 mm[.125 in]
Row-to-Row Spacing	2.54 mm[.1 in]



Usage Conditions

Housing Temperature Rating	Standard
Operating Temperature Range	-65 – 105 °C[-85 – 221 °F]

Operation/Application

Solder Process Feature	Solder Dipped
Circuit Application	Signal

Industry Standards

UL Flammability Rating	UL 94V-0
------------------------	----------

Packaging Features

Packaging Quantity	30
Packaging Method	Tray

Product Compliance

[For compliance documentation, visit the product page on TE.com>](#)

EU RoHS Directive 2011/65/EU	Not Compliant
EU ELV Directive 2000/53/EC	Compliant with Exemptions
China RoHS 2 Directive MIIT Order No 32, 2016	Restricted Materials Above Threshold
EU REACH Regulation (EC) No. 1907/2006	Current ECHA Candidate List: JUNE 2023 (235) Candidate List Declared Against: JUNE 2023 (235) SVHC > Threshold: Pb (13% in Component Part) Article Safe Usage Statements: Do not eat, drink or smoke when using this product. Wash thoroughly after handling. Recycle if possible and dispose of the article by following all applicable governmental regulations relevant to your geographic location.
Halogen Content	Not Low Halogen - contains Br or Cl > 900 ppm.
Solder Process Capability	Wave solder capable to 265°C

Product Compliance Disclaimer

This information is provided based on reasonable inquiry of our suppliers and represents our current actual knowledge based on the information they provided. This information is subject to change. The part numbers that TE has identified as EU RoHS compliant have a maximum concentration of 0.1% by weight in homogenous materials for lead, hexavalent chromium, mercury, PBB, PBDE, DBP, BBP, DEHP, DIBP, and 0.01% for cadmium, or qualify for an exemption to these limits as defined in the Annexes of Directive 2011/65/EU (RoHS2). Finished electrical and electronic equipment products will be CE marked as required by Directive 2011/65/EU. Components may not be CE marked. Additionally, the part numbers that TE has identified as EU ELV compliant have a maximum concentration of 0.1% by weight in homogenous materials for lead, hexavalent chromium, and mercury, and 0.01% for cadmium, or qualify for an exemption to these limits as defined in the Annexes of Directive 2000/53/EC (ELV). Regarding the REACH Regulation, the information TE provides

on SVHC in articles for this part number is based on the latest European Chemicals Agency (ECHA) 'Guidance on requirements for substances in articles' posted at this URL: <https://echa.europa.eu/guidance-documents/guidance-on-reach>

Compatible Parts



Also in the Series | AMP-LATCH Universal Headers

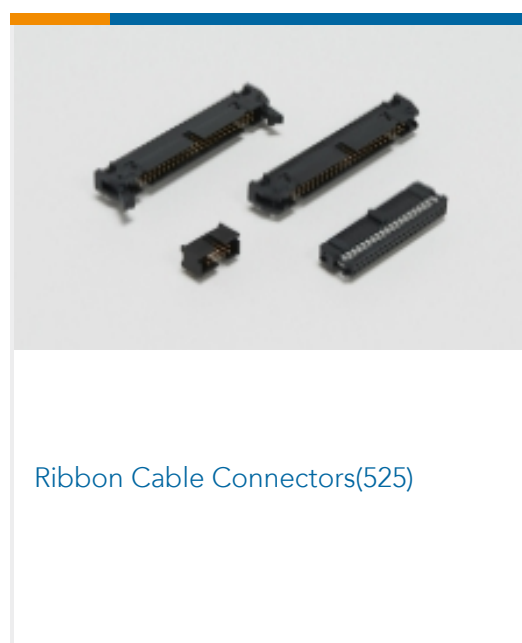

Customers Also Bought

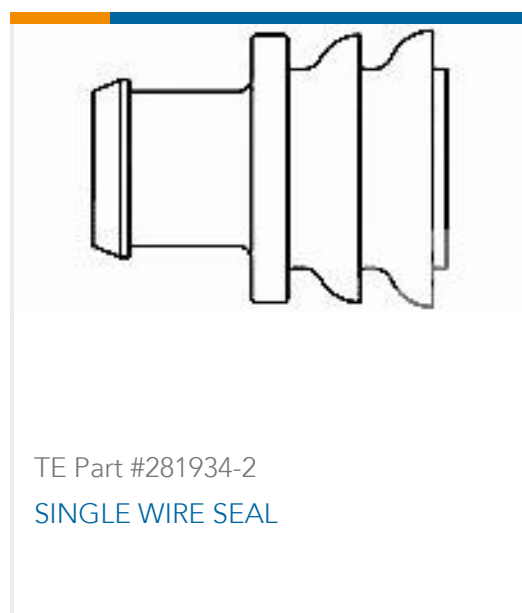

Documents

Product Drawings



050 UNIV HDR SP 4S 15DP STD

English

CAD Files

3D PDF

3D

Customer View Model

[ENG_CVM_CVM_1-102155-0_N.2d_dxf.zip](#)

English

Customer View Model

[ENG_CVM_CVM_1-102155-0_N.3d_igs.zip](#)

English

Customer View Model

[ENG_CVM_CVM_1-102155-0_N.3d_stp.zip](#)

English

By downloading the CAD file I accept and agree to the [Terms and Conditions](#) of use.

Product Specifications

Product Specification

English

Instruction Sheets

Instruction Sheet (U.S.)

English

AMP INSTALLATION PROCEDURES FOR AMP-LATCH UNIVERSAL HEADER ASSEMBLIE

English

Agency Approvals

Agency Approval Document

English