

## NDS352AP

### P-Channel Logic Level Enhancement Mode Field Effect Transistor

#### General Description

These P-Channel logic level enhancement mode power field effect transistors are produced using Nationals proprietary, high cell density, DMOS technology. This very high density process is especially tailored to minimize on-state resistance. These devices are particularly suited for low voltage applications such as notebook computer power management, portable electronics, and other battery powered circuits where fast high-side switching, and low in-line power loss are needed in a very small outline surface mount package.

#### Features

- -0.9 A, -30 V.  $R_{DS(ON)} = 0.5 \Omega @ V_{GS} = -4.5 \text{ V}$   
 $R_{DS(ON)} = 0.3 \Omega @ V_{GS} = -10 \text{ V}$ .
- Industry standard outline SOT-23 surface mount package using proprietary SuperSOT™-3 design for superior thermal and electrical capabilities.
- High density cell design for extremely low  $R_{DS(ON)}$ .
- Exceptional on-resistance and maximum DC current capability.

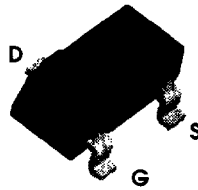

SuperSOT™-3 (SOT-23)

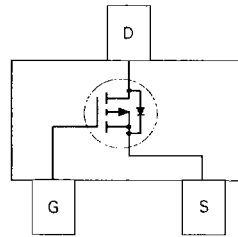

#### Absolute Maximum Ratings $T_A = 25^\circ\text{C}$ unless otherwise noted

| Symbol         | Parameter  |  | NDS352AP   | Units            |
|----------------|--|--|------------|------------------|
| $V_{DS}$       | Drain-Source Voltage                             |  | -30        | V                |
| $V_{GSS}$      | Gate-Source Voltage - Continuous                 |  | $\pm 20$   | V                |
| $I_D$          | Maximum Drain Current - Continuous (Note 1a)     |  | $\pm 0.9$  | A                |
|                | - Pulsed   |  | $\pm 10$   |                  |
| $P_D$          | Maximum Power Dissipation (Note 1a)<br>(Note 1b) |  | 0.5        | W                |
|                |  |  | 0.46       |                  |
| $T_J, T_{STG}$ | Operating and Storage Temperature Range          |  | -55 to 150 | $^\circ\text{C}$ |

#### THERMAL CHARACTERISTICS

|                 |   |  |     |                    |
|-----------------|---|--|-----|--------------------|
| $R_{\theta JA}$ | Thermal Resistance, Junction-to-Ambient (Note 1a) |  | 250 | $^\circ\text{C/W}$ |
| $R_{\theta JC}$ | Thermal Resistance, Junction-to-Case (Note 1)     |  | 75  | $^\circ\text{C/W}$ |

**Electrical Characteristics** ( $T_A = 25^\circ\text{C}$  unless otherwise noted)

| Symbol                                    | Parameter                         | Conditions  | Min  | Typ  | Max  | Units         |               |
|---|-----------------------------------|---|--|------|------|---------------|---------------|
| <b>OFF CHARACTERISTICS</b>                |                                   |   |  |      |      |               |               |
| $BV_{DS}$                                 | Drain-Source Breakdown Voltage    | $V_{GS} = 0\text{ V}, I_D = -250\ \mu\text{A}$  | -30  |      |      | V             |               |
| $I_{DSS}$                                 | Zero Gate Voltage Drain Current   | $V_{DS} = -24\text{ V}, V_{GS} = 0\text{ V}$  |  |      | -1   | $\mu\text{A}$ |               |
|   |                                   |   | $T_J = 125^\circ\text{C}$                  |      |      | -10           | $\mu\text{A}$ |
| $I_{GSSF}$                                | Gate - Body Leakage, Forward      | $V_{GS} = 20\text{ V}, V_{DS} = 0\text{ V}$   |  |      | 100  | nA            |               |
| $I_{GSSR}$                                | Gate - Body Leakage, Reverse      | $V_{GS} = -20\text{ V}, V_{DS} = 0\text{ V}$  |  |      | -100 | nA            |               |
| <b>ON CHARACTERISTICS</b> (Note 2)        |                                   |   |  |      |      |               |               |
| $V_{GS(th)}$                              | Gate Threshold Voltage            | $V_{DS} = V_{GS}, I_D = -250\ \mu\text{A}$  |  | -0.8 | -1.7 | -2.5          | V             |
|   |                                   |   | $T_J = 125^\circ\text{C}$                  | -0.5 | -1.4 | -2.2          |               |
| $R_{DS(on)}$                              | Static Drain-Source On-Resistance | $V_{GS} = -4.5\text{ V}, I_D = -0.9\text{ A}$   |  |      | 0.45 | 0.5           | $\Omega$      |
|   |                                   |   | $T_J = 125^\circ\text{C}$                  |      | 0.65 | 0.7           |               |
|   |                                   |   | $V_{GS} = -10\text{ V}, I_D = -1\text{ A}$ |      | 0.25 | 0.3           |               |
| $I_{D(on)}$                               | On-State Drain Current            | $V_{GS} = -4.5\text{ V}, V_{DS} = -5\text{ V}$  | -2   |      |      | A             |               |
| $g_{FS}$                                  | Forward Transconductance          | $V_{DS} = -5\text{ V}, I_D = -0.9\text{ A}$   |  | 1.9  |      | S             |               |
| <b>DYNAMIC CHARACTERISTICS</b>            |                                   |   |  |      |      |               |               |
| $C_{iss}$                                 | Input Capacitance                 | $V_{DS} = -15\text{ V}, V_{GS} = 0\text{ V},$<br>$f = 1.0\text{ MHz}$                       |  | 135  |      | pF            |               |
| $C_{oss}$                                 | Output Capacitance                |   |  | 88   |      | pF            |               |
| $C_{rss}$                                 | Reverse Transfer Capacitance      |   |  | 40   |      | pF            |               |
| <b>SWITCHING CHARACTERISTICS</b> (Note 2) |                                   |   |  |      |      |               |               |
| $t_{D(on)}$                               | Turn - On Delay Time              | $V_{DD} = -6\text{ V}, I_D = -1\text{ A},$<br>$V_{GS} = -4.5\text{ V}, R_{GEN} = 6\ \Omega$ |  | 5    | 10   | ns            |               |
| $t_r$                                     | Turn - On Rise Time               |   |  | 17   | 30   | ns            |               |
| $t_{D(off)}$                              | Turn - Off Delay Time             |   |  | 35   | 70   | ns            |               |
| $t_f$                                     | Turn - Off Fall Time              |   |  | 30   | 60   | ns            |               |
| $Q_g$                                     | Total Gate Charge                 | $V_{DS} = -10\text{ V}, I_D = -0.9\text{ A},$<br>$V_{GS} = -4.5\text{ V}$                   |  | 2    | 3    | nC            |               |
| $Q_{gs}$                                  | Gate-Source Charge                |   |  | 0.5  |      | nC            |               |
| $Q_{gd}$                                  | Gate-Drain Charge                 |   |  | 1    |      | nC            |               |

## Electrical Characteristics ( $T_A = 25^\circ\text{C}$ unless otherwise noted)

| Symbol  | Parameter   | Conditions                                     | Min | Typ  | Max   | Units |
|---|---|--|-----|------|-------|-------|
| <b>DRAIN-SOURCE DIODE CHARACTERISTICS AND MAXIMUM RATINGS</b> |   |  |     |      |       |       |
| $I_S$   | Maximum Continuous Source Current                 |  |     |      | -0.42 | A     |
| $I_{SM}$  | Maximum Pulsed Drain-Source Diode Forward Current |  |     |      | -10   | A     |
| $V_{SD}$  | Drain-Source Diode Forward Voltage                | $V_{GS} = 0\text{ V}$ , $I_S = -0.42$ (Note 2) |     | -0.8 | -1.2  | V     |

**Notes:**

- $R_{\theta JA}$  is the sum of the junction-to-case and case-to-ambient thermal resistance where the case thermal reference is defined as the solder mounting surface of the drain pins.  $R_{\theta JC}$  is guaranteed by design while  $R_{\theta CA}$  is determined by the user's board design.

$$P_D(t) = \frac{T_J - T_A}{R_{\theta JA}(t)} = \frac{T_J - T_A}{R_{\theta JC} + R_{\theta CA}(t)} = I_D^2(t) \times R_{DS(on)} @ T_J$$

Typical  $R_{\theta JA}$  using the board layouts shown below on 4.5"x5" FR-4 PCB in a still air environment:

- 250°C/W when mounted on a 0.02 in<sup>2</sup> pad of 2oz copper.
- 270°C/W when mounted on a 0.001 in<sup>2</sup> pad of 2oz copper.

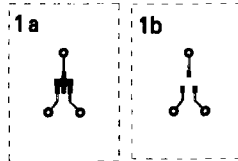

Scale 1: 1 on letter size paper

- Pulse Test: Pulse Width  $\leq 300\mu\text{s}$ , Duty Cycle  $\leq 2.0\%$ .

# Typical Electrical Characteristics

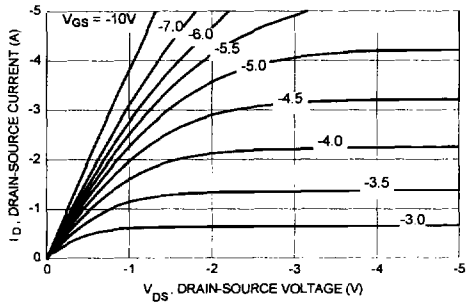

Figure 1. On-Region Characteristics

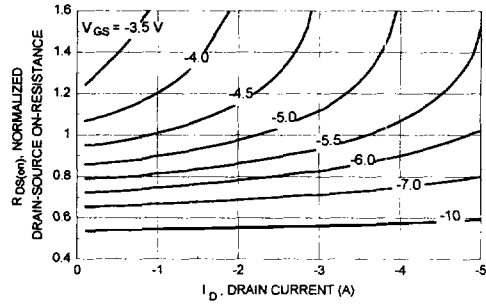

Figure 2. On-Resistance Variation with Drain Current and Gate Voltage

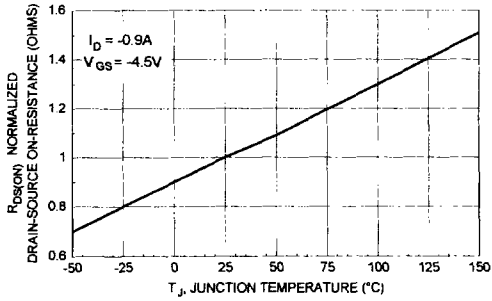

Figure 3. On-Resistance Variation with Temperature

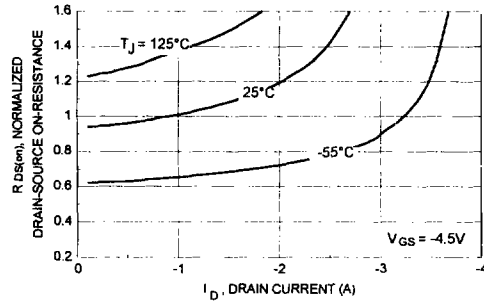

Figure 4. On-Resistance Variation with Drain Current and Temperature

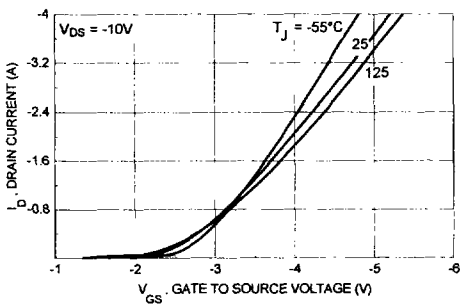

Figure 5. Transfer Characteristics

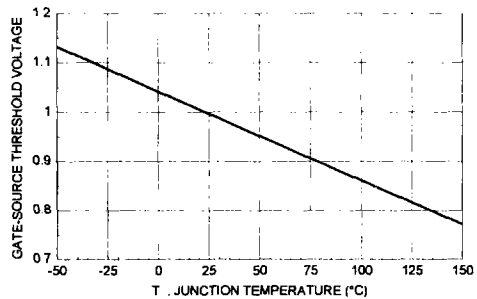

Figure 6. Gate Threshold Variation with Temperature

## Typical Electrical Characteristics (continued)

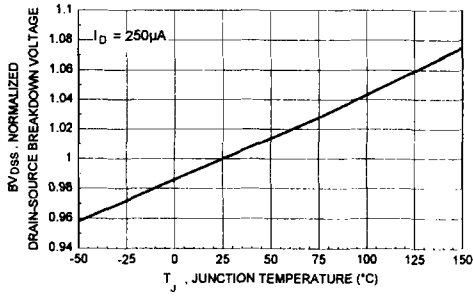

Figure 7. Breakdown Voltage Variation with Temperature

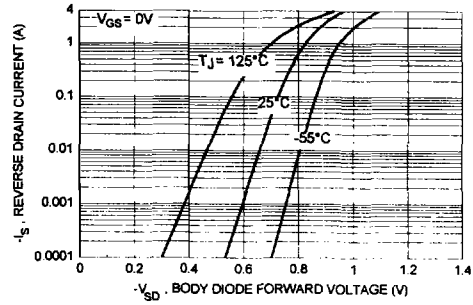

Figure 8. Body Diode Forward Voltage Variation with Source Current and Temperature

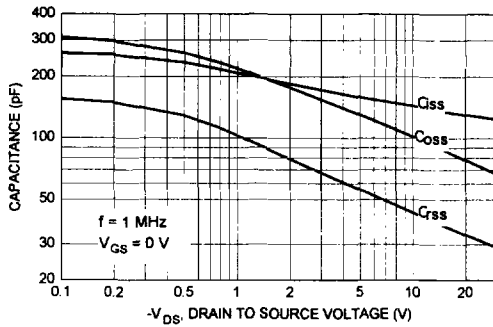

Figure 9. Capacitance Characteristics

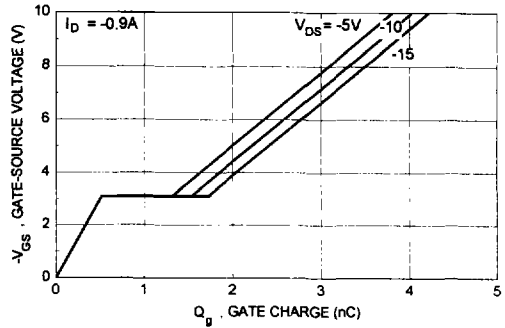

Figure 10. Gate Charge Characteristics

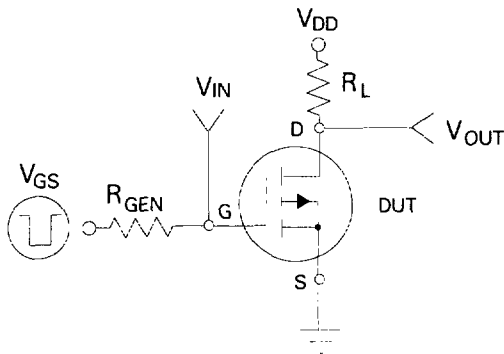

Figure 11. Switching Test Circuit

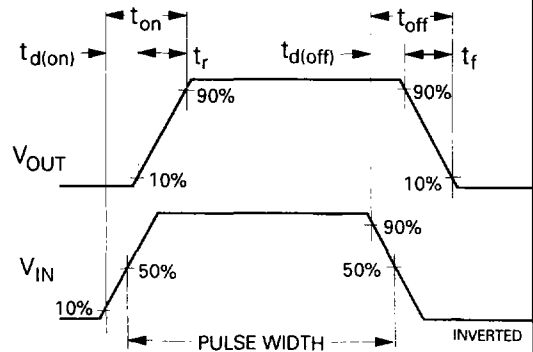

Figure 12. Switching Waveforms

## Typical Electrical Characteristics (continued)

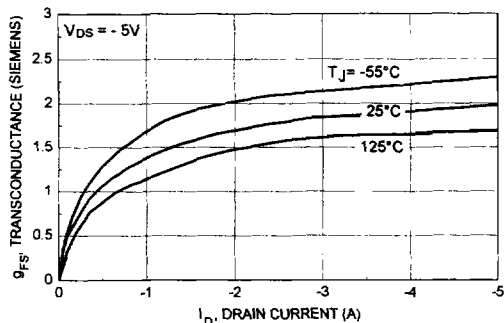

Figure 13. Transconductance Variation with Drain Current and Temperature

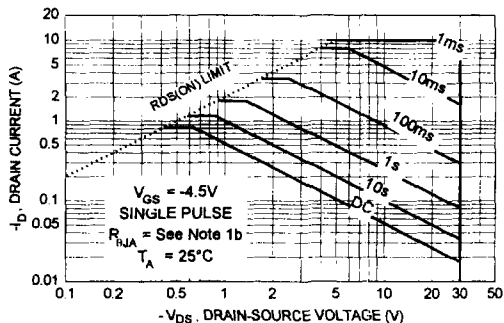

Figure 14. Maximum Safe Operating Area

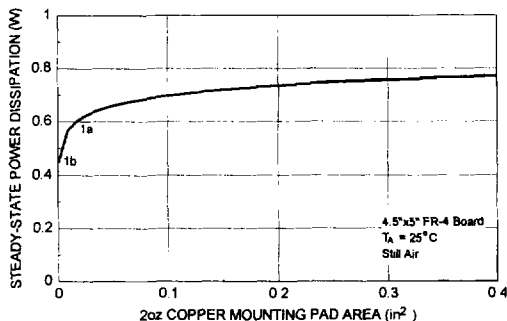

Figure 15. SuperSOT™-3 Maximum Steady-State Power Dissipation versus Copper Mounting Pad Area.

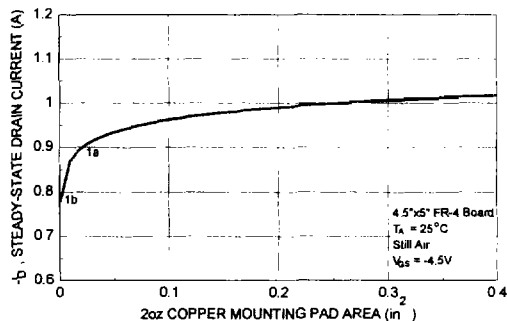

Figure 16. Maximum Steady-State Drain Current versus Copper Mounting Pad Area

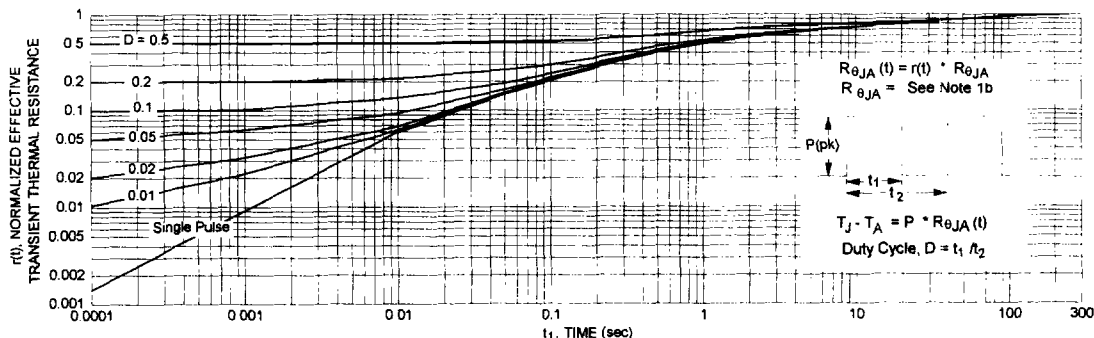

Figure 17. Transient Thermal Response Curve

Note : Characterization performed using the conditions described in note 1b. Transient thermal response will change depending on the circuit board design.