



DESCRIPTION — The SN54LS/74LS604 thru SN54LS/74LS607 are multiplexed latches designed for storing data from two input buses, A and B, and providing the stored data from either the A or B register to the output bus.

Data is loaded by the clock on the positive going transition (low-level to high-level). Control of the active and high impedance states of the outputs is also on the clock pin. The outputs are in the HIGH impedance or OFF state when the clock pin is LOW and the outputs are enabled when the clock pin is HIGH.

The SN54LS/74LS604 and 605 are designed for high speed operation and the SN54LS/74LS606 and 607 are designed to eliminate decoding voltage spikes. The SN54LS/74LS 604 and 606 have 3-state outputs while the SN54LS/74LS605 and 607 are open collector.

BLOCK DIAGRAM

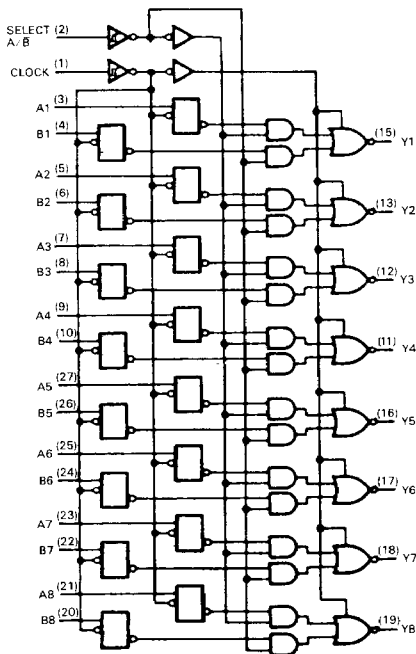

**SN54LS/74LS604
SN54LS/74LS605
SN54LS/74LS606
SN54LS/74LS607**

**OCTAL 2-INPUT
MULTIPLEXED LATCHES
LOW POWER SCHOTTKY**

**CONNECTION DIAGRAM
(TOP VIEW)**

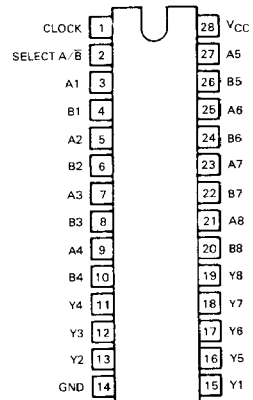

J Suffix — Case 733-02 (Ceramic)
N Suffix — Case 710-02 (Plastic)

FUNCTION TABLE

INPUTS				OUTPUTS
A1-A8	B1-B8	SELECT A/B	CLOCK	Y1-Y8
A data	B data	L	↑	B data
A data	B data	H	↑	A data
X	X	X	L	Z or Off
X	X	L	H	B register stored data
X	X	H	H	A register stored data

H = high level (steady state) L = low level (steady state)
X = irrelevant Z = high-impedance state
Off = H if pull-up resistor is connected to open-collector output
↑ = transition from low to high level

GUARANTEED OPERATING RANGES

SYMBOL	PARAMETER		MIN	TYP	MAX	UNIT
V _{CC}	Supply Voltage	54 74	4.5 4.75	5.0 5.0	5.5 5.25	V
T _A	Operating Ambient Temperature Range	54 74	-55 0	25 25	125 70	°C
I _{OH}	Output Current — High	54 74			-1.0 -2.6	mA
I _{OL}	Output Current — Low	54 74			12 24	mA

DC CHARACTERISTICS OVER OPERATING TEMPERATURE RANGE (unless otherwise specified)

SYMBOL	PARAMETER	LIMITS			UNITS	TEST CONDITIONS
		MIN	TYP	MAX		
V _{IH}	Input HIGH Voltage	2.0			V	Guaranteed Input HIGH Voltage for All Inputs
V _{IL}	Input LOW Voltage	54		0.7	V	Guaranteed Input LOW Voltage for All Inputs
		74		0.8		
V _{IK}	Input Clamp Diode Voltage		-0.65	-1.5	V	V _{CC} = MIN, I _{IN} = -18 mA
V _{OH}	Output HIGH Voltage	54	2.4	3.4	V	V _{CC} = MIN, I _{OH} = MAX, V _{IN} = V _{IH} or V _{IL} per Truth Table
		74	2.4	3.1	V	
V _{OL}	Output LOW Voltage	54,74	0.25	0.4	V	I _{OL} = 12 mA I _{OL} = 24 mA V _{CC} = V _{CC} MIN, V _{IN} = V _{IL} or V _{IH} per Truth Table
		74	0.35	0.5	V	
I _{OZH}	Output Off Current HIGH			20	μA	V _{CC} = MAX, V _O = 2.7 V
I _{OZL}	Output Off Current LOW			-20	μA	V _{CC} = MAX, V _O = 0.4 V
I _{IH}	Input HIGH Current			20	μA	V _{CC} = MAX, V _{IN} = 2.7 V
				-0.1	mA	V _{CC} = MAX, V _{IN} = 7.0 V
I _{IL}	Input LOW Current	A,B		-0.4	mA	V _{CC} = MAX, V _{IN} = 0.4 V
		CK, Select		-0.2	mA	
I _{OS}	Short Circuit Current		-30	-130	mA	V _{CC} = MAX
I _{CC}	Power Supply Current			70	mA	V _{CC} = MAX

AC CHARACTERISTICS: T_A = 25°C

SYMBOL	PARAMETER	LS604			LS606			UNITS	TEST CONDITIONS
		LIMITS			LIMITS				
		MIN	TYP	MAX	MIN	TYP	MAX		
t _{PLH}	Select A/ \bar{B} , Data: A = H, B = L		15	25		36	50	ns	V _{CC} = 5.0 V C _L = 45 pF, R _L = 667 Ω
t _{PHL}	Select A/ \bar{B} , Data: A = L, B = H		31	45		22	35		
t _{PLH}	Select A/ \bar{B} , Data: A = L, B = H		19	30		22	35		
t _{PZH}	Clock to Output		19	30		27	40	ns	
t _{PZL}			27	40		35	50		
t _{PLZ}	Clock to Output		20	30		20	30	ns	
t _{PHZ}			15	25		15	25		

AC SETUP REQUIREMENTS: T_A = 25°C

SYMBOL	PARAMETER	LIMITS			UNITS	CONDITIONS
		MIN	TYP	MAX		
t _W	Clock Pulse Width	20			ns	V _{CC} = 5.0 V
t _s	Setup Time	20			ns	
t _h	Hold Time	0			ns	

GUARANTEED OPERATING RANGES

SYMBOL	PARAMETER		MIN	TYP	MAX	UNIT
V _{CC}	Supply Voltage	54 74	4.5 4.75	5.0 5.0	5.5 5.25	V
T _A	Operating Ambient Temperature Range	54 74	-55 0	25 25	125 70	°C
V _{OH}	Output Voltage — High	54,74			5.5	V
I _{OL}	Output Current — Low	54 74			12 24	mA

DC CHARACTERISTICS OVER OPERATING TEMPERATURE RANGE (unless otherwise specified)

SYMBOL	PARAMETER	LIMITS			UNITS	TEST CONDITIONS
		MIN	TYP	MAX		
V _{IH}	Input HIGH Voltage	2.0			V	Guaranteed Input HIGH Voltage for All Inputs
V _{IL}	Input LOW Voltage	54		0.7	V	Guaranteed Input LOW Voltage for All Inputs
		74		0.8		
V _{IK}	Input Clamp Diode Voltage		-0.65	-1.5	V	V _{CC} = MIN, I _{IN} = -18 mA
I _{OH}	Output HIGH Current	54,74		250	μA	V _{CC} = MIN, V _{OH} = MAX
V _{OL}	Output LOW Voltage	54,74	0.25	0.4	V	I _{OL} = 12 mA V _{CC} = V _{CC} MIN, V _{IN} = V _{IL} or V _{IH} per Truth Table
		74	0.35	0.5	V	
I _{IH}	Input HIGH Current			20	μA	V _{CC} = MAX, V _{IN} = 2.7 V
				0.1	mA	V _{CC} = MAX, V _{IN} = 7.0 V
I _{IL}	Input LOW Current	A, B		-0.4	mA	V _{CC} = MAX, V _{IN} = 0.4 V
		CK, Select		-0.2	mA	
I _{CC}	Power Supply Current			60	mA	V _{CC} = MAX

5

AC CHARACTERISTICS: T_A = 25°C

SYMBOL	PARAMETER	LS605			LS607			UNITS	TEST CONDITIONS
		LIMITS			LIMITS				
		MIN	TYP	MAX	MIN	TYP	MAX		
t _{PLH}	Select A/B, Data: A = H, B = L		28	40		51	70	ns	V _{CC} = 5.0 V C _L = 45 pF, R _L = 667 Ω
t _{PHL}			28	40		21	30		
t _{PLH}	Select A/B, Data: A = L, B = H		39	60		28	40		
t _{PHL}			25	40		28	40		
t _{PLH}	Clock to Output		27	40		30	45		
t _{PHL}			25	40		32	45		

AC SETUP REQUIREMENTS: T_A = 25°C

SYMBOL	PARAMETER	LIMITS			UNITS	CONDITIONS
		MIN	TYP	MAX		
t _W	Clock Pulse Width		20		ns	V _{CC} = 5.0 V
t _s	Setup Time		20		ns	
t _h	Hold Time		0		ns	