

RN2114, 2115, 2116 RN2117, 2118

(RN2114)

SWITCHING, INVERTER CIRCUIT, INTERFACE CIRCUIT
AND DRIVER CIRCUIT APPLICATIONS.

- With Built-in Bias Resistors
- Simplify Circuit Design
- Reduce a Quantity of Parts and Manufacturing Process
- Complementary to RN1114~RN1118

EQUIVALENT CIRCUIT AND BIAS RESISTOR VALUES

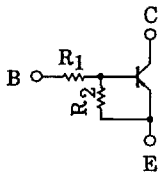

TYPE No.	R ₁ (kΩ)	R ₂ (kΩ)
RN2114	1	10
RN2115	2.2	10
RN2116	4.7	10
RN2117	10	4.7
RN2118	47	10

Unit in mm

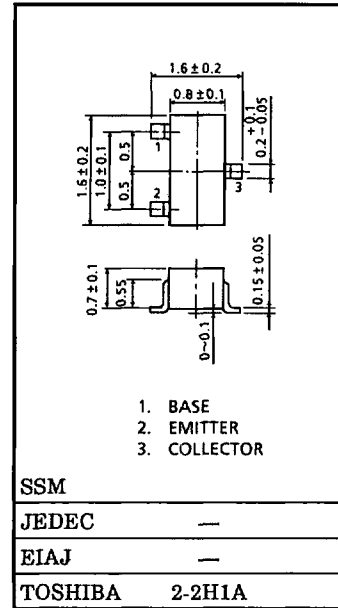

SSM

JEDEC —

EIAJ —

TOSHIBA 2-2H1A

Weight : 2.4mg

MAXIMUM RATINGS (Ta = 25°C)

CHARACTERISTIC		SYMBOL	RATING	UNIT
Collector-Base Voltage	RN2114~2118	V _{CB0}	-50	V
Collector-Emitter Voltage		V _{CE0}	-50	V
Emitter-Base Voltage	RN2114	V _{EB0}	-5	V
	RN2115		-6	
	RN2116		-7	
	RN2117		-15	
	RN2118		-25	
Collector Current	RN2114~2118	I _C	-100	mA
Collector Power Dissipation		P _C	100	mW
Junction Temperature		T _j	150	°C
Storage Temperature Range		T _{stg}	-55~150	°C

RN2114, 2115, 2116
RN2117, 2118

(RN2114)

ELECTRICAL CHARACTERISTICS (Ta = 25°C)

CHARACTERISTIC		SYMBOL	TEST CONDITION	MIN.	TYP.	MAX.	UNIT
Collector Cut-off Current	RN2114~2118	I_{CBO}	$V_{CB} = -50V, I_E = 0$	—	—	-100	nA
	RN2114~2118	I_{CEO}	$V_{CE} = -50V, I_B = 0$	—	—	-500	nA
Emitter Cut-off Current	RN2114	I_{EBO}	$V_{EB} = -5V, I_C = 0$	-0.35	—	-0.65	mA
	RN2115		$V_{EB} = -6V, I_C = 0$	-0.37	—	-0.71	
	RN2116		$V_{EB} = -7V, I_C = 0$	-0.36	—	-0.68	
	RN2117		$V_{EB} = -15V, I_C = 0$	-0.78	—	-1.46	
	RN2118		$V_{EB} = -25V, I_C = 0$	-0.33	—	-0.63	
DC Current Gain	RN2114~16, 18	h_{FE}	$V_{CE} = -5V, I_C = -10mA$	50	—	—	
	RN2117			30	—	—	
Collector-Emitter Saturation Voltage	RN2114~2118	$V_{CE(sat)}$	$I_C = -5mA, I_B = -0.25mA$	—	-0.1	-0.3	V
Input Voltage (ON)	RN2114	$V_{I(ON)}$	$V_{CE} = -0.2V, I_C = -5mA$	-0.5	—	-2.0	V
	RN2115			-0.6	—	-2.5	
	RN2116			-0.7	—	-2.5	
	RN2117			-1.5	—	-3.5	
	RN2118			-2.5	—	-10.0	
Input Voltage (OFF)	RN2114	$V_{I(OFF)}$	$V_{CE} = -5V, I_C = -0.1mA$	-0.3	—	-0.9	V
	RN2115			-0.3	—	-1.0	
	RN2116			-0.3	—	-1.1	
	RN2117			-0.3	—	-3.0	
	RN2118			-0.5	—	-5.7	
Transition Frequency	RN2114~2118	f_T	$V_{CE} = -10V, I_C = -5mA$	—	200	—	MHz
Collector Output Capacitance	RN2114~2118	C_{ob}	$V_{CB} = -10V, I_E = 0, f = 1MHz$	—	3.0	6.0	pF
Input Resistor	RN2114	R_1	—	0.7	1.0	1.3	kΩ
	RN2115			1.54	2.2	2.86	
	RN2116			3.29	4.7	6.11	
	RN2117			7.0	10.0	13.0	
	RN2118			32.9	47.0	61.1	
Resistor Ratio	RN2114	R_1 / R_2	—	—	0.1	—	
	RN2115			—	0.22	—	
	RN2116			—	0.47	—	
	RN2117			—	2.13	—	
	RN2118			—	4.7	—	

RN2114, 2115, 2116 RN2117, 2118

(RN2114)

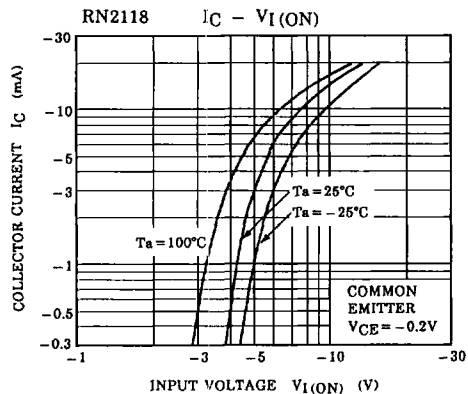
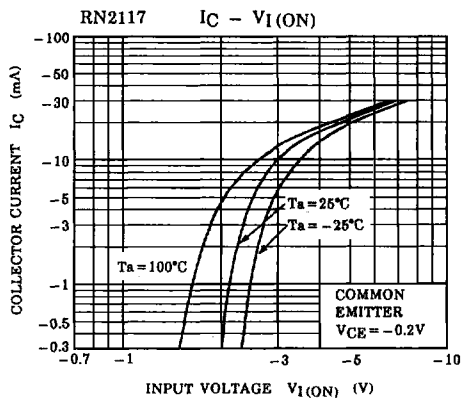
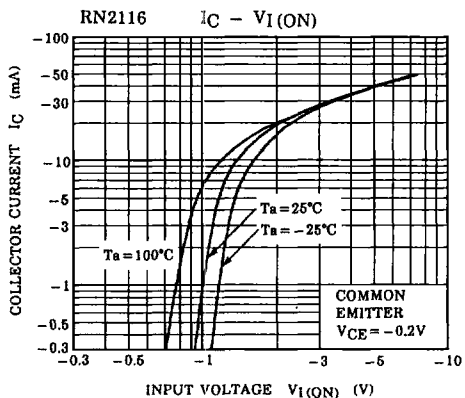
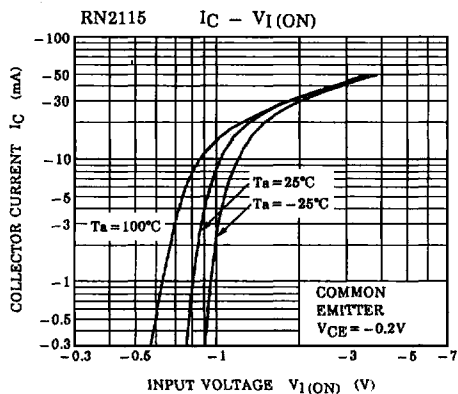
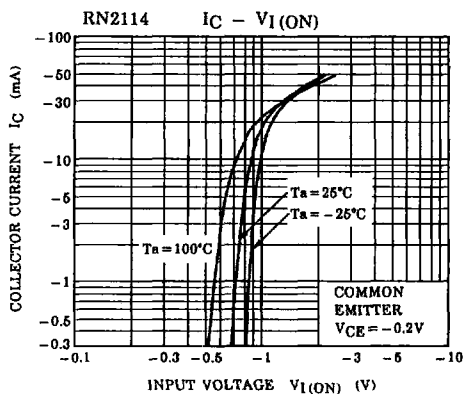

RN2114, 2115, 2116 RN2117, 2118

(RN2114)

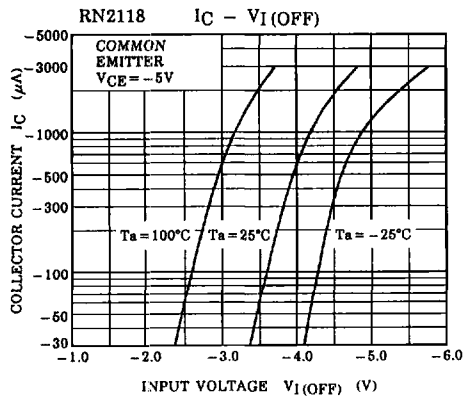
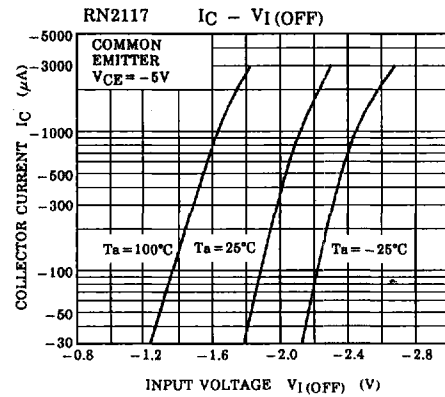
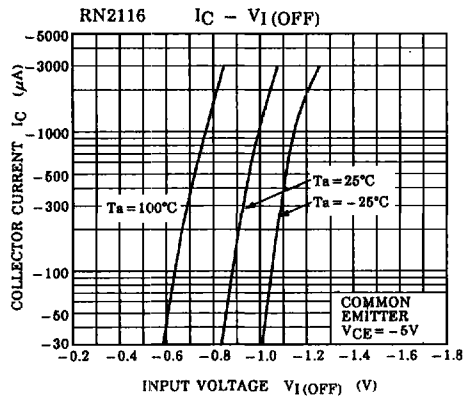
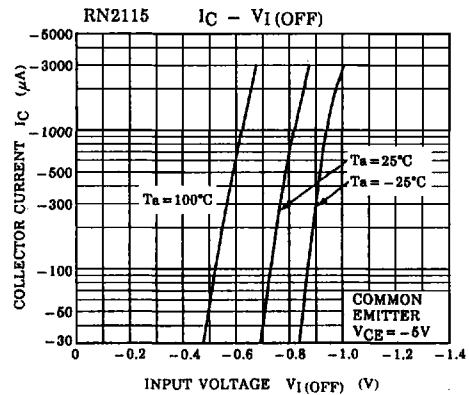
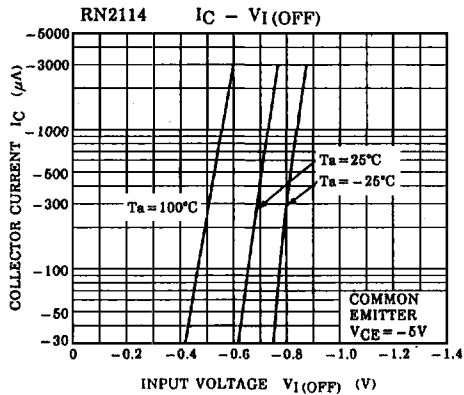

RN2114, 2115, 2116 RN2117, 2118

(RN2114)

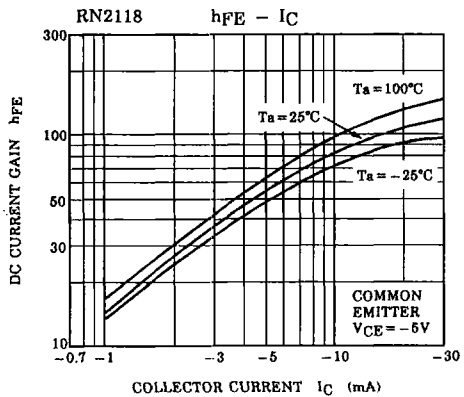
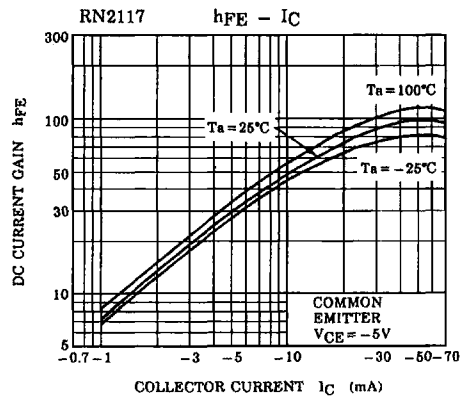
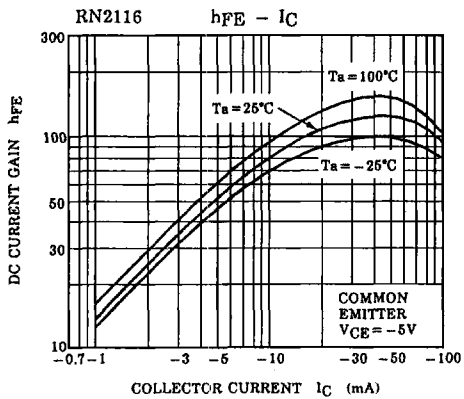
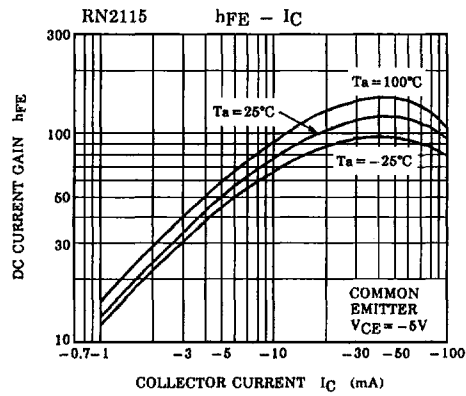
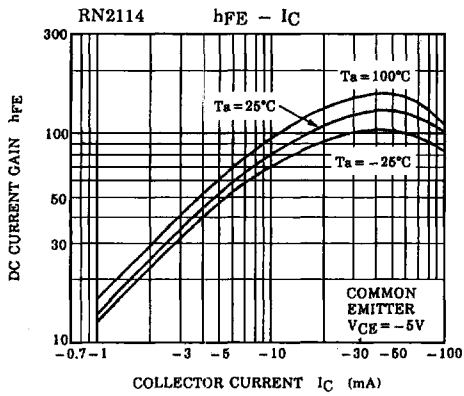

RN2114, 2115, 2116 RN2117, 2118

(RN2114)

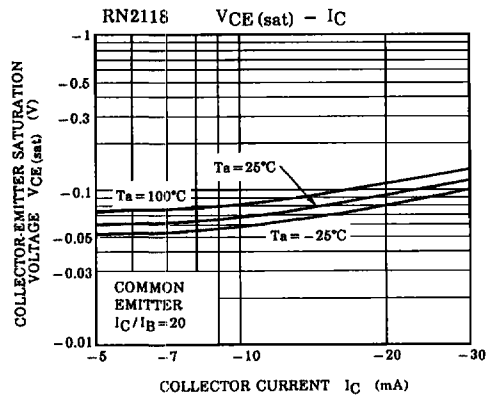
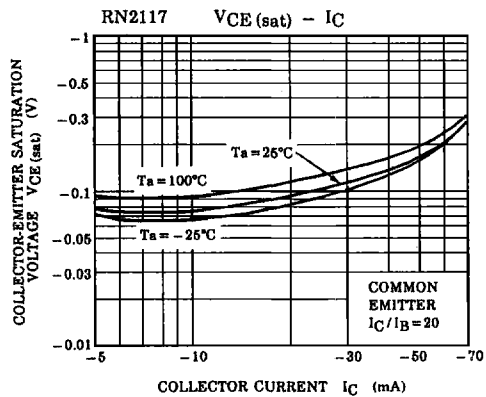
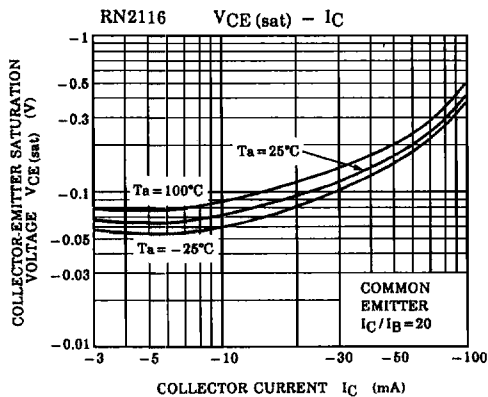
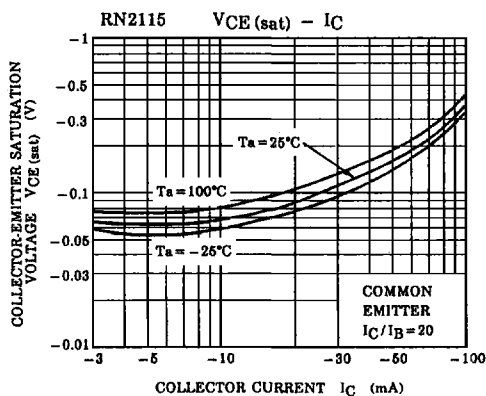
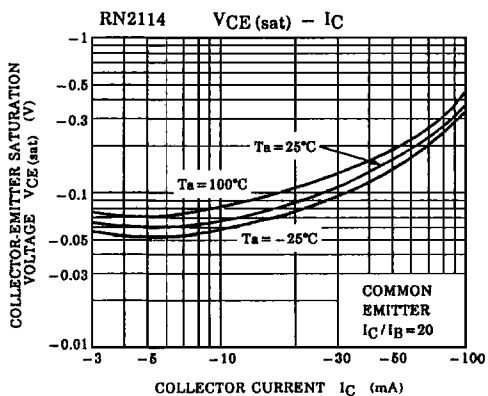

**RN2114, 2115, 2116
RN2117, 2118**

(RN2114)

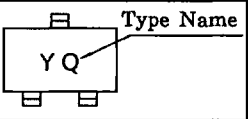
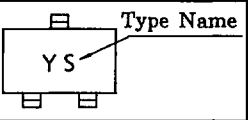
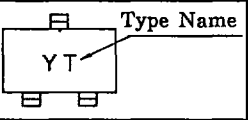
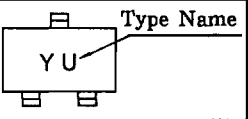
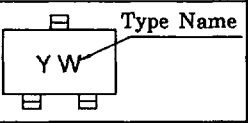
TYPE NAME	MARKING
RN2114	 <p>The diagram shows a rectangular box containing the letters 'YQ'. Above the box is a small square symbol with a horizontal line extending to the right, labeled 'Type Name'. A diagonal line points from the 'Type Name' label to the 'Q' in the box. Below the box are two small square symbols.</p>
RN2115	 <p>The diagram shows a rectangular box containing the letters 'YS'. Above the box is a small square symbol with a horizontal line extending to the right, labeled 'Type Name'. A diagonal line points from the 'Type Name' label to the 'S' in the box. Below the box are two small square symbols.</p>
RN2116	 <p>The diagram shows a rectangular box containing the letters 'YT'. Above the box is a small square symbol with a horizontal line extending to the right, labeled 'Type Name'. A diagonal line points from the 'Type Name' label to the 'T' in the box. Below the box are two small square symbols.</p>
RN2117	 <p>The diagram shows a rectangular box containing the letters 'YU'. Above the box is a small square symbol with a horizontal line extending to the right, labeled 'Type Name'. A diagonal line points from the 'Type Name' label to the 'U' in the box. Below the box are two small square symbols.</p>
RN2118	 <p>The diagram shows a rectangular box containing the letters 'YW'. Above the box is a small square symbol with a horizontal line extending to the right, labeled 'Type Name'. A diagonal line points from the 'Type Name' label to the 'W' in the box. Below the box are two small square symbols.</p>