



## LH0062/LH0062C High Speed FET Operational Amplifier

### General Description

The LH0062/LH0062C is a precision, high speed FET input operational amplifier with more than an order of magnitude improvement in slew rate and bandwidth over conventional FET IC op amps. In addition it features very closely matched input characteristics, very high input impedance, and ultra low input currents with no compromise in noise, common mode rejection ratio or open loop gain. The device has internal unity gain frequency compensation, thus assuring stability in all normal applications. This considerably simplifies its application, since no external components are necessary for operation. However, unlike most internally compensated amplifiers, external frequency compensation may be added for optimum performance. For inverting applications, feed-forward compensation will boost the slew rate to over 120 V/ $\mu$ s and almost double the bandwidth. (See LB-2, LB-14, and LB-17 for discussions of the application of feed-forward techniques). Over-compensation can be used with the amplifier for greater stability when maximum bandwidth is not needed. Further, a single capacitor can be added to reduce the 0.1% settling time to under 1  $\mu$ s. In addition it is free of latch-up and may be simply offset nulled with negligible effect on offset drift or CMRR.

The LH0062 is designed for applications requiring wide bandwidth, high slew rate and fast settling time while at the same time demanding the high input impedance and low input currents characteristic of FET inputs. Thus it is particularly suited for such applications as video amplifiers, sample/hold circuits, high speed integrators, and buffers for A/D conversion and multiplex system. The LH0062 is specified for the full military temperature range of  $-55^{\circ}$  to  $+125^{\circ}$ C while the LH0062C is specified to operate over a  $-25^{\circ}$ C to  $+85^{\circ}$ C temperature range.

### Features

- High slew rate 70 V/ $\mu$ s
- Wide bandwidth 15 MHz
- Settling time (0.1%) 1  $\mu$ s
- Low input offset voltage 2 mV
- Low input offset current 1 pA
- Wide supply range  $\pm 5$ V to  $\pm 20$ V
- Internal 6 dB/octave frequency compensation
- Pin compatible with std IC op amps (TO-5 pkg)

### Schematic Diagram

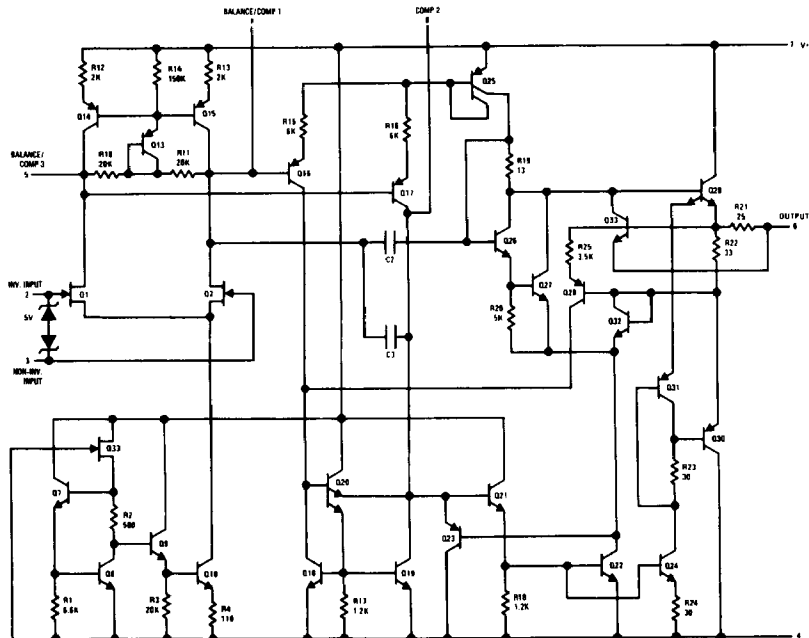

\*Pin Numbers Shown for TO-5 Package

TL/K/6862-1

## Absolute Maximum Ratings

If Military/Aerospace specified devices are required, please contact the National Semiconductor Sales Office/Distributors for availability and specifications. (Note 5)

Supply Voltage	±20V
Power Dissipation (see graph)	500 mW
Input Voltage (Note 1)	±5V
Differential Input Voltage (Note 2)	±30V

Short Circuit Duration	Continuous
Operating Temperature	
LH0062	-55°C to +125°C
LH0062C	-25°C to +85°C
Storage Temperature Range	-65°C to +150°C
Lead Temperature (Soldering, 10 sec.)	260°C
ESD rating to be determined.	

## DC Electrical Characteristics (Note 3)

Parameter	Conditions	Limits						Units
		LH0062			LH0062C			
		Min	Typ	Max	Min	Typ	Max	
Input Offset Voltage	$R_S \leq 100 \text{ k}\Omega$ , $T_A = 25^\circ\text{C}$ , $R_S \leq 100 \text{ k}\Omega$		2	5 7		10	15 20	mV mV
Temperature Coefficient of Input Offset Voltage	$R_S \leq 100 \text{ k}\Omega$		25			25		$\mu\text{V}/^\circ\text{C}$
Offset Voltage Drift with Time			4			5		$\mu\text{V}/\text{week}$
Input Offset Current	$T_A = 25^\circ\text{C}$		0.2	2 2		1	5 0.2	pA nA
Temperature Coefficient of Input Offset Current			Doubles every 10°C			Doubles every 10°C		
Offset Current Drift with Time			0.1			0.1		pA/week
Input Bias Current	$T_A = 25^\circ\text{C}$ (Note 4)		5	10 10		10	65 2	pA nA
Temperature Coefficient of Input Bias Current			Doubles every 10°C			Doubles every 10°C		
Differential Input Resistance			10 <sup>12</sup>			10 <sup>12</sup>		$\Omega$
Common Mode Input Resistance			10 <sup>12</sup>			10 <sup>12</sup>		$\Omega$
Input Capacitance			4			4		pF
Input Voltage Range	$V_S = \pm 15\text{V}$	±10	±12		±10	±12		V
Common Mode Rejection Ratio	$R_S \leq 10 \text{ k}\Omega$ , $V_{IN} = \pm 10\text{V}$	80	90		70	90		dB
Supply Voltage Rejection Ratio	$R_S \leq 10 \text{ k}\Omega$ , $\pm 5\text{V} \leq V_S \leq \pm 15\text{V}$	80	90		70	90		dB
Large Signal Voltage Gain	$R_L = 2 \text{ k}\Omega$ , $V_{OUT} = \pm 10\text{V}$ , $T_A = 25^\circ\text{C}$ , $V_S = \pm 15\text{V}$ $R_L = 2 \text{ k}\Omega$ , $V_{OUT} = \pm 10\text{V}$ , $V_S = \pm 15\text{V}$	50	200		25	160		V/mV V/mV
Output Voltage Swing	$R_L = 2 \text{ k}\Omega$ , $T_A = 25^\circ\text{C}$ , $V_S = \pm 15\text{V}$ $R_L = 2 \text{ k}\Omega$ , $V_S = \pm 15\text{V}$	±12	±13		±12	13		V V
Output Current Swing	$V_{OUT} = \pm 10\text{V}$ , $T_A = 25^\circ\text{C}$	±10	±15		±10	±15		mA
Output Resistance			75			75		$\Omega$
Output Short Circuit Current	$T_A = 25^\circ\text{C}$		25			25		mA
Supply Current	$V_S = \pm 15\text{V}$		5	8		7	12	mA
Power Consumption	$V_S = \pm 15\text{V}$			240			360	mW

## AC Electrical Characteristics ( $T_A = 25^\circ\text{C}$ , $V_S = \pm 15\text{V}$ )

Parameter	Conditions	Limits						Units
		LH0062			LH0062C			
		Min	Typ	Max	Min	Typ	Max	
Slew Rate	Voltage Follower	50	70		50	70		V/ $\mu\text{s}$
Large Signal Bandwidth	Voltage Follower		2			2		MHz
Small Signal Bandwidth			15			15		MHz
Rise Time			25			25		ns
Overshoot			10			15		%
Settling Time (0.1%)	$\Delta V_{IN} = 10\text{V}$		1			1		$\mu\text{s}$
Overload Recovery			0.9			0.9		$\mu\text{s}$
Input Noise Voltage	$R_S = 10\text{ k}\Omega$ , $f_o = 10\text{ Hz}$		150			150		nV/ $\sqrt{\text{Hz}}$
Input Noise Voltage	$R_S = 10\text{ k}\Omega$ , $f_o = 100\text{ Hz}$		55			55		nV/ $\sqrt{\text{Hz}}$
Input Noise Voltage	$R_S = 10\text{ k}\Omega$ , $f_o = 1\text{ kHz}$		35			35		nV/ $\sqrt{\text{Hz}}$
Input Noise Voltage	$R_S = 10\text{ k}\Omega$ , $f_o = 10\text{ kHz}$		30			30		nV/ $\sqrt{\text{Hz}}$
Input Noise Voltage	$\text{BW} = 10\text{ Hz to } 10\text{ kHz}$ , $R_S = 10\text{ k}\Omega$		12			12		$\mu\text{Vrms}$
Input Noise Current	$\text{BW} = 10\text{ Hz to } 10\text{ kHz}$		<0.1			<0.1		pArms

**Note 1:** For supply voltages less than  $\pm 15\text{V}$ , the absolute maximum input voltage is equal to the supply voltage.

**Note 2:** Inputs are protected from excessive voltages by back-to-back diodes. Input currents should be limited to 1 mA.

**Note 3:** Unless otherwise specified, these specifications apply for  $\pm 5\text{V} \leq V_S \leq \pm 20\text{V}$  and  $-55^\circ\text{C} \leq T_A \leq +125^\circ\text{C}$  for the LH0062 and  $-25^\circ\text{C} \leq T_A \leq +85^\circ\text{C}$  for the LH0062C. Typical values are given for  $T_A = 25^\circ\text{C}$ . Power supplies should be bypassed with 0.1  $\mu\text{F}$  ceramic capacitors.

**Note 4:** Input currents are a strong function of temperature. Due to high speed testing they are specified at a junction temperature  $T = 25^\circ\text{C}$ , self heating will cause an increase in current in manual tests.  $25^\circ\text{C}$  spec is guaranteed by testing at  $125^\circ\text{C}$ .

**Note 5:** Refer to RETS0062X for LH0062D and LH0062H military specifications.

## Connection Diagrams

### Metal Can Package

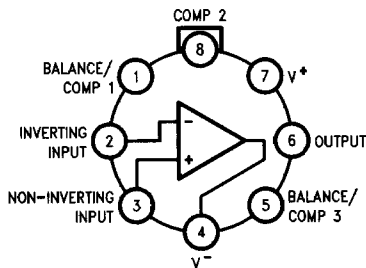

Top View

Order Number LH0062H or LH0062CH  
See NS Package Number H08D

TL/K/6862-2

### Dual-In-Line Package

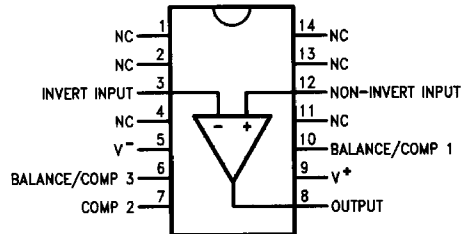

Top View

Order Number LH0062D or LH0062CD  
See NS Package Number D14E

TL/K/6862-3

# Typical Performance Characteristics

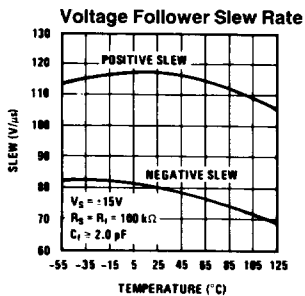
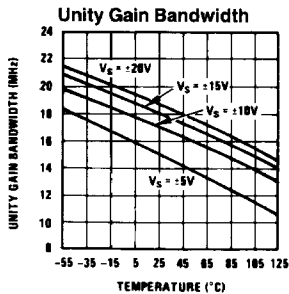
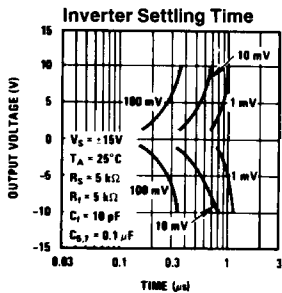
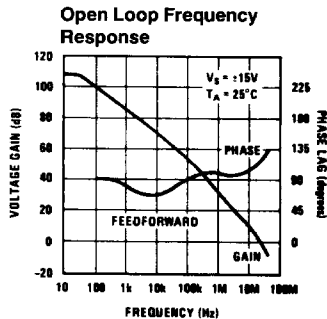
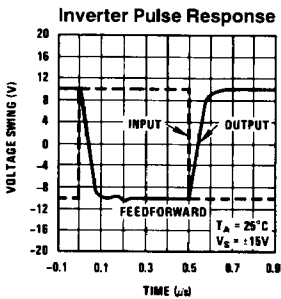
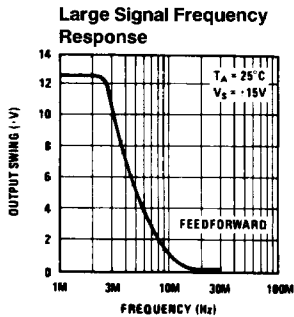
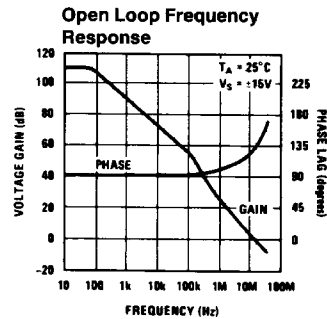
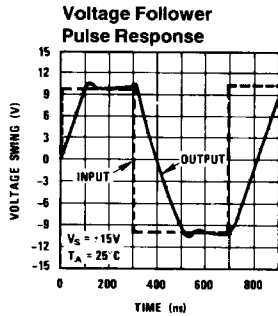
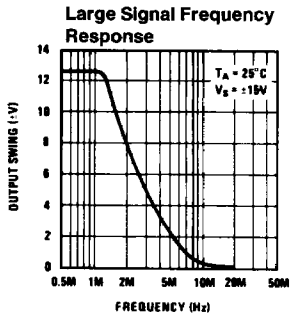
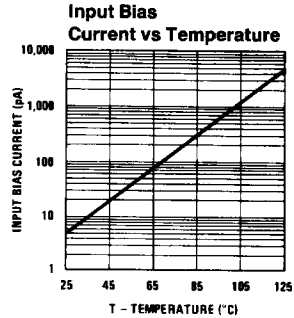
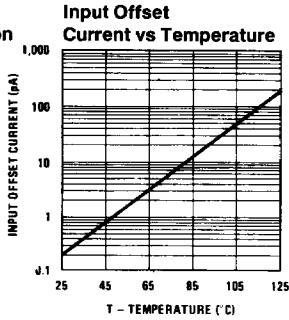
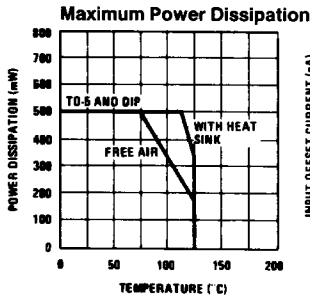

# Typical Performance Characteristics (Continued)

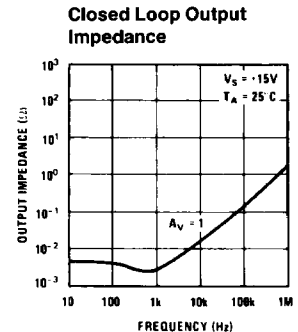
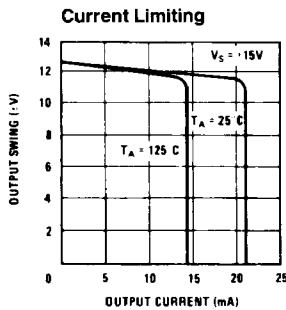
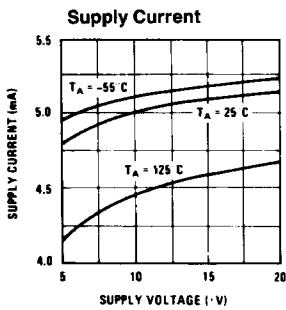
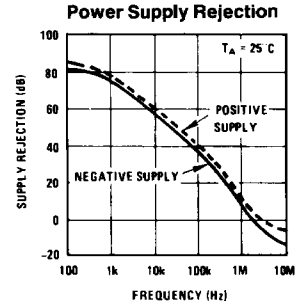
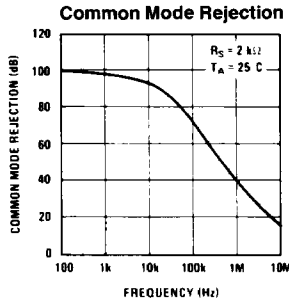
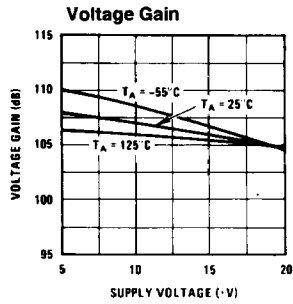
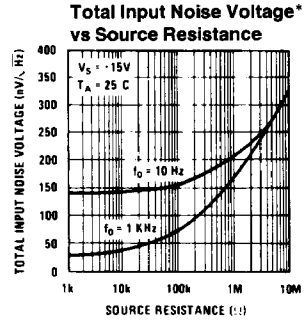
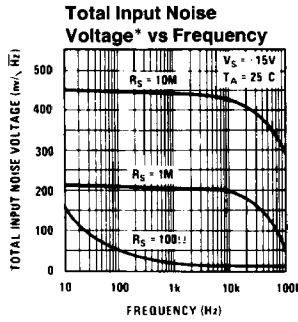
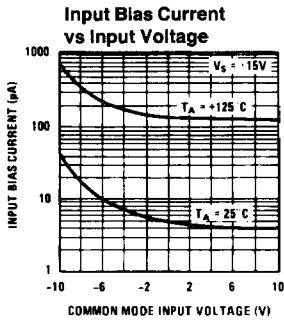

TL/K/6862-5

\*Noise Voltage Includes Contribution from Source Resistance

# Auxiliary Circuits

## Feedforward Compensation for Greater Inverting Slew Rate†

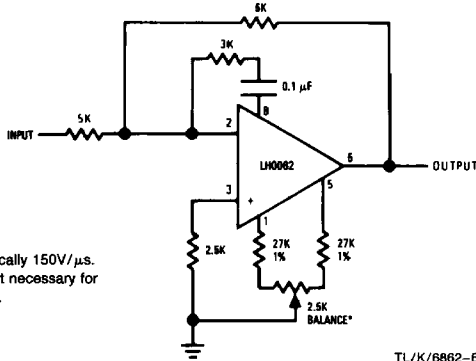

†Slew rate typically 150V/μs.  
\*Balance circuit necessary for increased slew.

TL/K/6862-6

## Offset Balancing

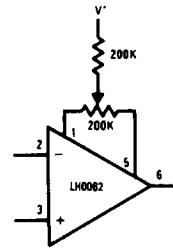

TL/K/6862-7

## Compensation for Minimum Settling† Time

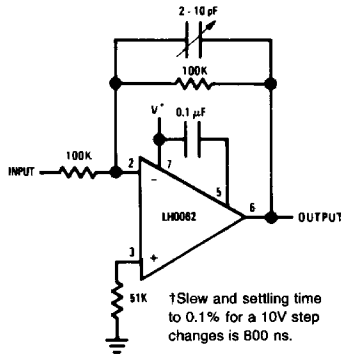

†Slew and settling time to 0.1% for a 10V step changes is 800 ns.

TL/K/6862-8

## Isolating Large Capacitive Loads

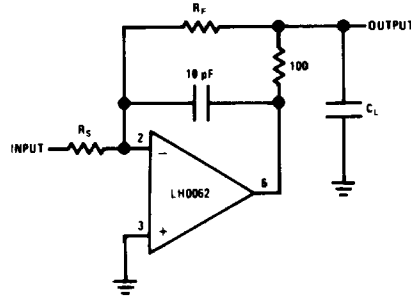

TL/K/6862-9

## Overcompensation

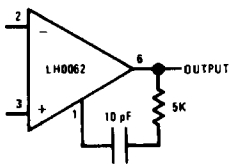

TL/K/6862-10

## Boosting Output Drive to ± 100 mA

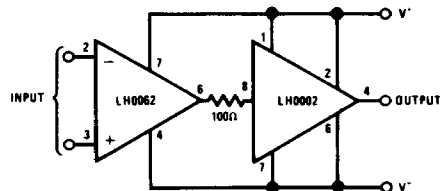

TL/K/6862-11

# Typical Applications\*

## Fast Voltage Follower

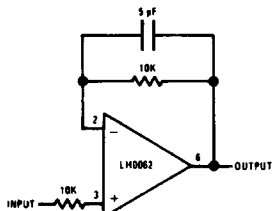

TL/K/6862-12

## Fast Summing Amplifier

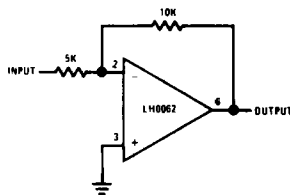

TL/K/6862-13

## Differential Amplifier

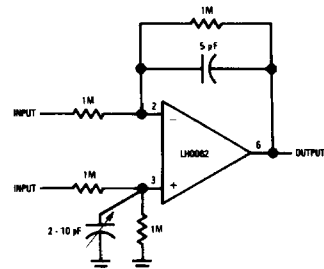

TL/K/6862-14

Typical Applications\* (Continued)

High Speed Subtractor

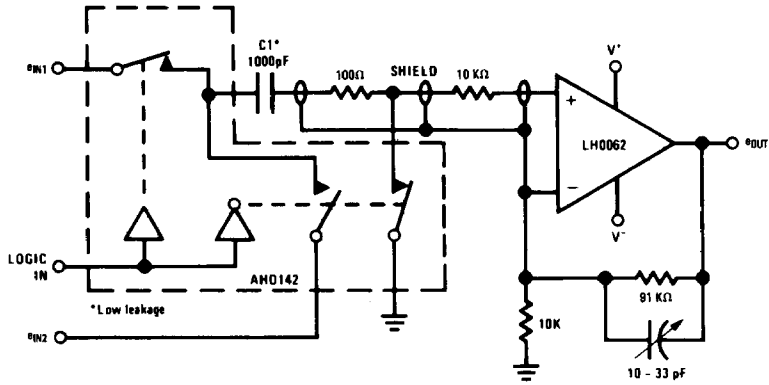

TL/K/6862-15

Fast Precision Voltage Comparator

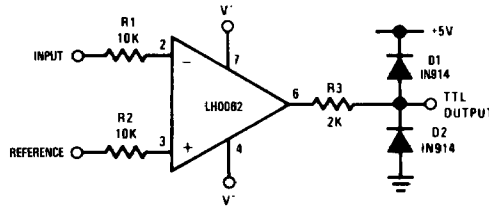

TL/K/6862-16

Wide Range AC Voltmeter

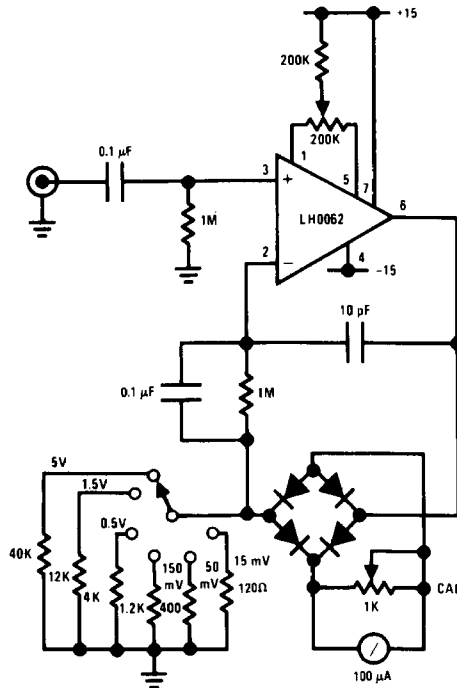

TL/K/6862-17

Typical Applications\* (Continued)

Video DC Restoring Amplifier

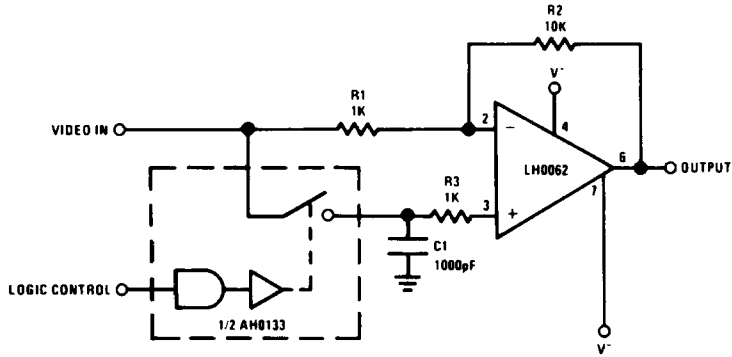

\*Pin numbers shown for TO-5 package

TL/K/6862-18

High Speed Positive Peak Detector

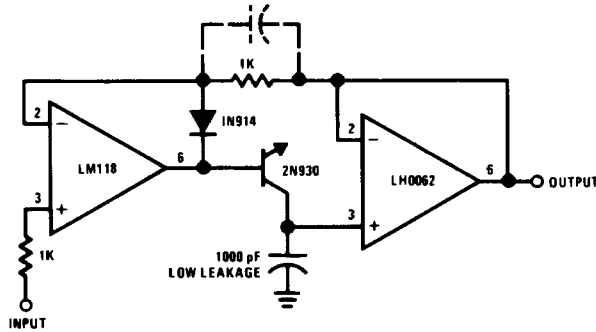

TL/K/6862-19

Precision Integrator

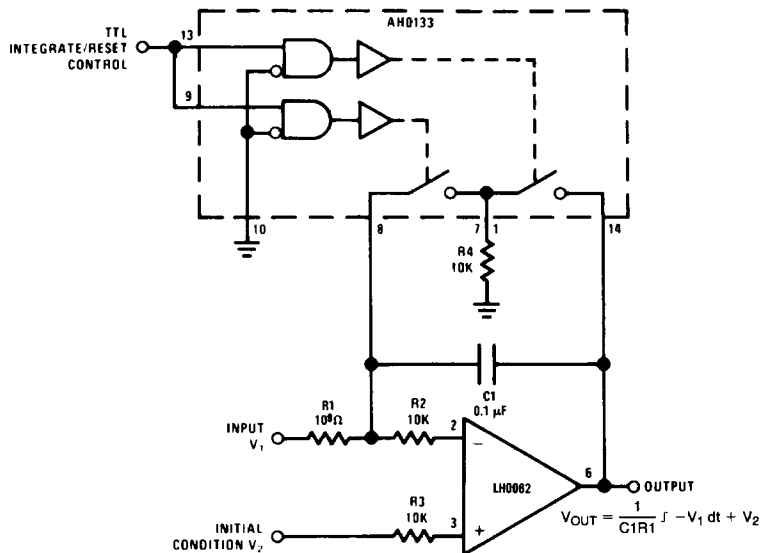

\*Pin numbers shown for TO-5 package

TL/K/6862-20



Typical Applications\* (Continued)

Precision Wide Range Current to Period Converter

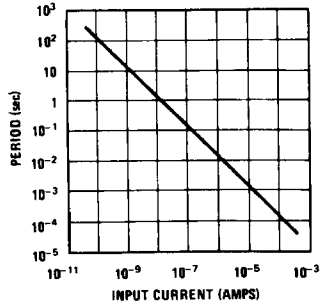

TL/K/6862-21

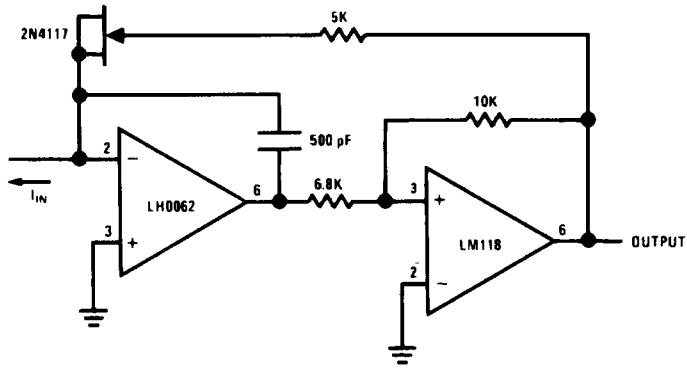

TL/K/6862-22