

INCH-POUND

MIL-M-38510/346C

19 April 2004

SUPERSEDING

MIL-M-38510/346B

12 February 1987

MILITARY SPECIFICATION

MICROCIRCUITS, DIGITAL, BIPOLAR, ADVANCED SCHOTTKY TTL,
TRANSPARENT AND OCTAL D TYPE LATCHES, CASCADABLE, MONOLITHIC SILICON

Reactivated after 19 April 2004 and may be used for either new or existing design acquisition.

This specification is approved for use by all Departments
and Agencies of the Department of Defense.

The requirements for acquiring the product herein shall consist of this specification sheet and MIL-PRF 38535

1. SCOPE

1.1 Scope. This specification covers the detail requirements for monolithic silicon, advanced Schottky TTL, octal transparent and octal D type latches (three state) microcircuits. Two product assurance classes and a choice of case outlines and lead finishes are provided for each type and are reflected in the complete part number. For this product, the requirements of MIL-M-38510 have been superseded by MIL-PRF-38535, (see 6.3).

1.2 Part or Identifying Number (PIN). The PIN is in accordance with MIL-PRF-38535, and as specified herein.

1.2.1 Device types. The device types are as follows:

<u>Device type</u>	<u>Circuit</u>
01	Octal transparent latch with active low enable 3-state outputs
02	Octal transparent latch with active low enable 3-state outputs
03	Octal D-type latch with 3-state inverted outputs
04	Octal D-type latch with 3-state outputs

1.2.2 Device class. The device class is the product assurance level as defined in MIL-PRF-38535.

1.2.3 Case outlines. The case outlines are as designated in MIL-STD-1835 and as follows:

<u>Outline letter</u>	<u>Descriptive designator</u>	<u>Terminals</u>	<u>Package style</u>
R	GDIP1-T20 or CDIP2-T20	20	Dual-in-line
S	GDFP2-F20 or CDFP3-F20	20	Flat pack
2	CQCC1-N20	20	Square leadless chip carrier
X	CQCC2-N20	20	Square leadless chip carrier

Comments, suggestions, or questions on this document should be addressed to: Commander, Defense Supply Center Columbus, ATTN: DSCC-VAS, 3990 East Broad St., Columbus, OH 43216-5000, or emailed to bipolar@dsccl.dla.mil. Since contact information can change, you may want to verify the currency of this address information using the ASSIST Online database at www.dodssp.daps.mil.

1.3 Absolute maximum ratings.

Supply voltage range	-0.5 V dc to +7.0 V dc
Input voltage range	-1.2 V dc at -18 mA to +7.0 V dc
Storage temperature range	-65° to +150°C
Maximum power dissipation, per device (P_D) ^{1/}	
Device type 01	330 mW
Device type 02	385 mW
Device type 03	336 mW
Device type 04	303 mW
Lead temperature (soldering, 10 seconds)	+300°C
Thermal resistance, junction to case (θ_{JC})	(See MIL-STD-1835)
Junction temperature (T_J) ^{2/}	175°C

1.4 Recommended operating conditions.

Supply voltage (V_{CC})	4.5 V dc minimum to 5.5 V dc maximum
Minimum high level input voltage (V_{IH})	2.0 V dc
Maximum low level input voltage (V_{IL})	0.8 V dc
Width of latch enable pulse high $t_{PW(LEH)}$:	
Device types 01 and 02	6.0 ns minimum
Device types 03 and 04	4.0 ns minimum
Setup time data high to latch enable pulse $t_{S(H)}$:	
All device types	2.0 ns minimum
Setup time data low to latch enable pulse $t_{S(L)}$:	
All device types	2.0 ns minimum
Hold time data high to latch enable pulse $t_{H(H)}$:	
Device type 01	4.0 ns minimum
Device types 02, 03, 04	3.0 ns minimum
Hold time data low to high latch enable pulse $t_{H(L)}$:	
Device types 01 and 04	4.0 ns minimum
Device types 02 and 03	3.0 ns minimum
Case operating temperature range (T_C)	-55° to +125°C

2. APPLICABLE DOCUMENTS

2.1 General. The documents listed in this section are specified in sections 3, 4, or 5 of this specification. This section does not include documents cited in other sections of this specification or recommended for additional information or as examples. While every effort has been made to ensure the completeness of this list, document users are cautioned that they must meet all specified requirements of documents cited in sections 3, 4, or 5 of this specification, whether or not they are listed.

^{1/} Must withstand the added P_D due to short-circuit test (e.g., I_{OS}).

^{2/} Maximum junction temperature should not be exceeded except in accordance with allowable short duration burn-in screening condition in accordance with MIL-PRF-38535.

2.2 Government documents.

2.2.1 Specifications and Standards. The following specifications and standards form a part of this specification to the extent specified herein. Unless otherwise specified, the issues of these documents are those cited in the solicitation or contract.

DEPARTMENT OF DEFENSE SPECIFICATIONS

MIL-PRF-38535 - Integrated Circuits (Microcircuits) Manufacturing, General Specification for.

DEPARTMENT OF DEFENSE STANDARDS

MIL-STD-883 - Test Method Standard for Microelectronics.
MIL-STD-1835 - Interface Standard Electronic Component Case Outlines

(Copies of these documents are available online at <http://assist.daps.dla.mil/quicksearch/> or www.dodssp.daps.mil or from the Standardization Document Order Desk, 700 Robbins Avenue, Building 4D, Philadelphia, PA 19111-5094.)

2.3 Order of precedence. In the event of a conflict between the text of this specification and the references cited herein, the text of this document takes precedence. Nothing in this document, however, supersedes applicable laws and regulations unless a specific exemption has been obtained.

3. REQUIREMENTS

3.1 Qualification. Microcircuits furnished under this specification shall be products that are manufactured by a manufacturer authorized by the qualifying activity for listing on the applicable qualified manufacturers list before contract award (see 4.3 and 6.4).

3.2 Item requirements. The individual item requirements shall be in accordance with MIL-PRF-38535 and as specified herein or as modified in the device manufacturer's Quality Management (QM) plan. The modification in the QM plan shall not affect the form, fit, or function as described herein.

3.3 Design, construction, and physical dimensions. The design, construction, and physical dimensions shall be as specified in MIL-PRF-38535 and herein.

3.3.1 Terminal connections. The terminal connections shall be as specified on figure 1.

3.3.2 Logic diagrams. The logic diagrams shall be as specified on figure 2.

3.3.3 Truth tables and logic equations. The truth tables and logic equations shall be as specified on figure 3.

3.3.4 Schematic circuits. The schematic circuits shall be maintained by the manufacturer and made available to the qualifying activity and the preparing activity upon request.

3.3.3 Case outlines. The case outlines shall be as specified in 1.2.3.

3.4 Lead material and finish. The lead material and finish shall be in accordance with MIL-PRF-38535 (see 6.6).

3.5 Electrical performance characteristics. The electrical performance characteristics are as specified in table I, and apply over the full recommended case operating temperature range, unless otherwise specified.

3.6 Electrical test requirements. The electrical test requirements for each device class shall be the subgroups specified in table II. The electrical tests for each subgroup are described in table III.

3.7 Marking. Marking shall be in accordance with MIL-PRF-38535.

3.8 Microcircuit group assignment. The devices covered by this specification shall be in microcircuit group number 10 (see MIL-PRF-38535, appendix A).

4. VERIFICATION

4.1 Sampling and inspection. Sampling and inspection procedures shall be in accordance with MIL-PRF-38535 or as modified in the device manufacturer's Quality Management (QM) plan. The modification in the QM plan shall not effect the form, fit, or function as described herein.

4.2 Screening. Screening shall be in accordance with MIL-PRF-38535 and shall be conducted on all devices prior to qualification and conformance inspection. The following additional criteria shall apply:

- a. The burn-in test duration, test condition, and test temperature, or approved alternatives shall be as specified in the device manufacturer's QM plan in accordance with MIL-PRF-38535. The burn-in test circuit shall be maintained under document control by the device manufacturer's Technology Review Board (TRB) in accordance with MIL-PRF-38535 and shall be made available to the acquiring or preparing activity upon request. The test circuit shall specify the inputs, outputs, biases, and power dissipation, as applicable, in accordance with the intent specified in test method 1015 of MIL-STD-883.
- b. Interim and final electrical test parameters shall be as specified in table II, except interim electrical parameters test prior to burn-in is optional at the discretion of the manufacturer.
- c. Additional screening for space level product shall be as specified in MIL-PRF-38535.

4.3 Qualification inspection. Qualification inspection shall be in accordance with MIL-PRF-38535.

4.4 Technology Conformance inspection (TCI). Technology conformance inspection shall be in accordance with MIL-PRF-38535 and herein for groups A, B, C, and D inspections (see 4.4.1 through 4.4.4).

4.4.1 Group A inspection. Group A inspection shall be in accordance with table III of MIL-PRF-38535 and as follows:

- a. Tests shall be as specified in table II herein.
- b. Subgroups 4, 5, and 6 shall be omitted.

4.4.2 Group B inspection. Group B inspection shall be in accordance with table II of MIL-PRF-38535.

4.4.3 Group C inspection. Group C inspection shall be in accordance with table IV of MIL-PRF-38535 and as follows:

- a. End-point electrical parameters shall be as specified in table II herein.
- b. The steady-state life test duration, test condition, and test temperature, or approved alternatives shall be as specified in the device manufacturer's QM plan in accordance with MIL-PRF-38535. The burn-in test circuit shall be maintained under document control by the device manufacturer's Technology Review Board (TRB) in accordance with MIL-PRF-38535 and shall be made available to the acquiring or preparing activity upon request. The test circuit shall specify the inputs, outputs, biases, and power dissipation, as applicable, in accordance with the intent specified in test method 1005 of MIL-STD-883.

4.4.4 Group D inspection. Group D inspection shall be in accordance with table V of MIL-PRF-38535. End-point electrical parameters shall be as specified in table II herein.

4.5 Methods of inspection. Methods of inspection shall be specified as follows:

4.5.1 Voltage and current. All voltages given are referenced to the microcircuit ground terminal. Currents given are conventional and positive when flowing into the referenced terminal.

TABLE I. Electrical performance characteristics.

Test	Symbol	Conditions $-55^{\circ}\text{C} \leq T_C \leq +125^{\circ}\text{C}$	Device type	Limits		Unit
				Min	Max	
High level output voltage	V_{OH}	$V_{CC} = 4.5\text{ V}$, $V_{IL} = 0.8\text{ V}$, $I_{OH} = -1.0\text{ mA}$, $V_{IH} = 2.0\text{ V}$	All	2.5		V
Low level output voltage	V_{OL}	$V_{CC} = 4.5\text{ V}$, $I_{OH} = 20\text{ mA}$, $V_{IH} = 2.0\text{ V}$, $V_{IL} = 0.8\text{ V}$	All		0.5	V
Input clamp voltage	V_{IC}	$V_{CC} = 4.5\text{ V}$, $I_{IN} = -18\text{ mA}$, $T_C = +25^{\circ}\text{C}$	All		-1.2	V
High level input current	I_{IH1}	$V_{CC} = 5.5\text{ V}$, $V_{IH} = 2.7\text{ V}$	All		20	μA
	I_{IH2}	$V_{CC} = 5.5\text{ V}$, $V_{IH} = 7.0\text{ V}$	All		100	μA
Low level input current	I_{IL}	$V_{CC} = 5.5\text{ V}$, $V_{IL} = 0.5\text{ V}$	All	0.0	-0.6	mA
Short circuit output current <u>1/</u>	I_{OS}	$V_{CC} = 5.5\text{ V}$, $V_{OS} = 0\text{ V}$	All	-60	-150	mA
Output drive current	I_{OD}	$V_{CC} = 4.5\text{ V}$, $V_{OUT} = 2.5\text{ V}$ $V_{IN} = 2.5\text{ V}$	01, 02	35		mA
High level supply current	I_{CCH}	$V_{CC} = 5.5\text{ V}$	01		55	mA
			02		50	
Low level supply current	I_{CCL}	$V_{CC} = 5.5\text{ V}$	01		60	mA
			02		70	
			03		61	
			04		55	
Off-state supply current	I_{CCZ}	$V_{CC} = 5.5\text{ V}$ Outputs disabled	01		60	mA
			02, 03		61	
			04		55	
Off-state output leakage current	I_{OZH}	$V_{CC} = 5.5\text{ V}$, $V_{ZH} = 2.7\text{ V}$	All		50	μA
	I_{OZL}	$V_{CC} = 5.5\text{ V}$, $V_{ZL} = 0.5\text{ V}$	All		-50	μA

See footnotes at end of table.

MIL-M-38510/346C

TABLE I. Electrical performance characteristics - Continued.

Test	Symbol	Conditions -55°C ≤ T _C ≤ +125°C	Device type	Limits		Unit
				Min	Max	
Propagation delay time low to high level		V _{CC} = 5.0 V, C _L = 50 pF ± 10%, See figure 4				
D to Q	t _{PLH1}		01	3.0	8.5	ns
			04	3.0	9.0	
D to \bar{Q}	t _{PLH1}		02	4.0	12.0	ns
			03	3.0	10.5	
LE to Q	t _{PLH2}		01	5.0	15.0	ns
			04	5.0	13.5	
LE to \bar{Q}	t _{PLH2}		02	4.0	14.0	ns
			03	4.0	11.0	
Propagation delay time high to low level						
D to Q	t _{PHL1}		01	2.0	7.0	ns
			04	2.0	7.0	
D to \bar{Q}	t _{PHL1}		02	3.0	9.0	ns
			03	2.0	7.5	
LE to Q	t _{PHL2}		01	3.0	8.5	ns
			04	3.0	7.5	
LE to \bar{Q}	t _{PHL2}		02	3.0	9.0	ns
			03	2.5	7.5	
Propagation delay time low level to off-state						
\bar{OE} to Q	t _{PLZ1}		01	1.5	7.0	ns
			04	1.5	5.5	
\bar{OE} to \bar{Q}	t _{PLZ1}		02	1.5	7.5	ns
			03	1.5	5.5	
Propagation delay time high level to off-state						
\bar{OE} to Q	t _{PHZ1}		01	1.5	10.0	ns
			04	1.5	7.0	
\bar{OE} to \bar{Q}	t _{PHZ1}		02	1.5	8.5	ns
			03	1.5	7.0	

See footnotes at end of table.

MIL-M-38510/346C

TABLE I. Electrical performance characteristics - Continued.

Test	Symbol	Conditions -55°C ≤ T _C ≤ +125°C	Device type	Limits		Unit
				Min	Max	
Propagation delay time off-state to low level		V _{CC} = 5.0 V, C _L = 50 pF ± 10%, See figure 4				
\overline{OE} to Q	t _{PZL1}		01	2.0	10.0	ns
			04	2.0	10.0	
\overline{OE} to \overline{Q}	t _{PZL1}		02	2.0	9.0	ns
			03	2.5	10.0	
Propagation delay time off-state to high level						
\overline{OE} to Q	t _{PZH1}		01	2.0	15.0	ns
			04	2.0	10.0	
\overline{OE} to \overline{Q}	t _{PZH1}	02	2.0	12.5	ns	
		03	2.0	9.5		

1/ Not more than one output should be shorted at a time.

TABLE II. Electrical test requirements.

MIL-PRF-38535 test requirements	Subgroups (see table III)	
	Class S devices	Class B devices
Interim electrical parameters	1	1
Final electrical test parameters	1*, 2, 3, 7, 9, 10, 11	1*, 2, 3, 7, 9
Group A test requirements	1, 2, 3, 7, 8, 9, 10, 11	1, 2, 3, 7, 8, 9, 10, 11
Group B electrical test parameters when using the method 5005 QCI option	1, 2, 3, 7, 8, 9, 10, 11	N/A
Group C end-point electrical parameters	1, 2, 3, 7, 8, 9, 10, 11	1, 2, 3
Group D end-point electrical parameters	1, 2, 3	1, 2, 3

*PDA applies to subgroup 1.

Terminal number	Device 01	Device 02	Device 03	Device 04
	Cases R, S, X, 2	Cases R, S, X, 2	Cases R, S, X, 2	Cases R, S, X, 2
1	\overline{OE}	\overline{OE}	\overline{OE}	\overline{OE}
2	Q0	$\overline{Q} 0$	D0	D0
3	D0	D0	D1	D1
4	D1	D1	D2	D2
5	Q1	$\overline{Q} 1$	D3	D3
6	Q2	$\overline{Q} 2$	D4	D4
7	D2	D2	D5	D5
8	D3	D3	D6	D6
9	Q3	$\overline{Q} 3$	D7	D7
10	GND	GND	GND	GND
11	LE	LE	LE	LE
12	Q4	$\overline{Q} 4$	$\overline{Q} 7$	Q7
13	D4	D4	$\overline{Q} 6$	Q6
14	D5	D5	$\overline{Q} 5$	Q5
15	Q5	$\overline{Q} 5$	$\overline{Q} 4$	Q4
16	Q6	$\overline{Q} 6$	$\overline{Q} 3$	Q3
17	D6	D6	$\overline{Q} 2$	Q2
18	D7	D7	$\overline{Q} 1$	Q1
19	Q7	$\overline{Q} 7$	$\overline{Q} 0$	Q0
20	V _{CC}	V _{CC}	V _{CC}	V _{CC}

FIGURE 1. Terminal connections.

DEVICE TYPE 01

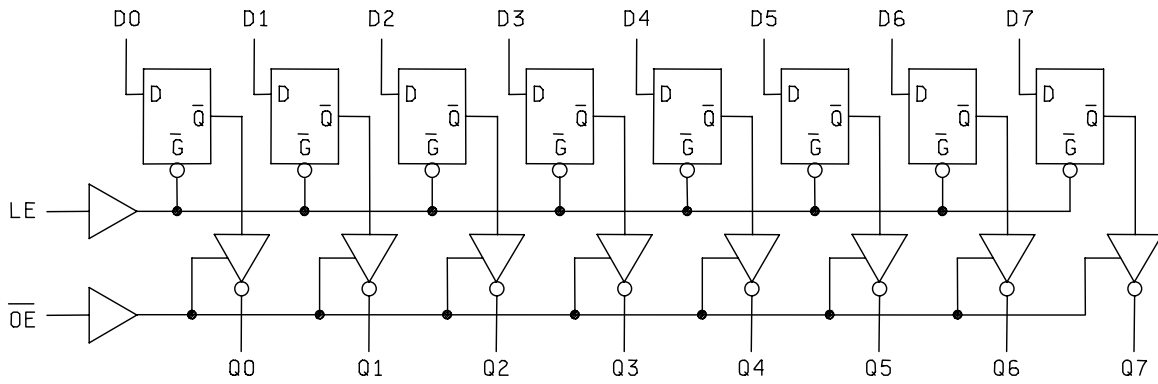

DEVICE TYPE 02

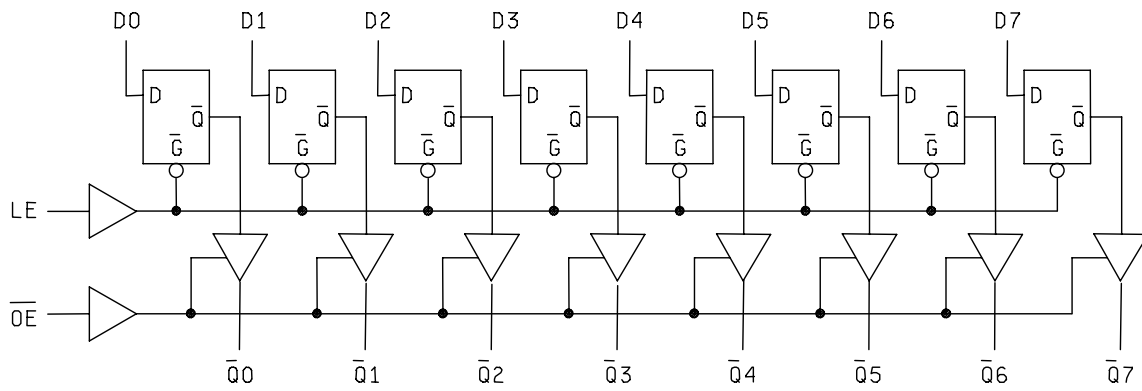
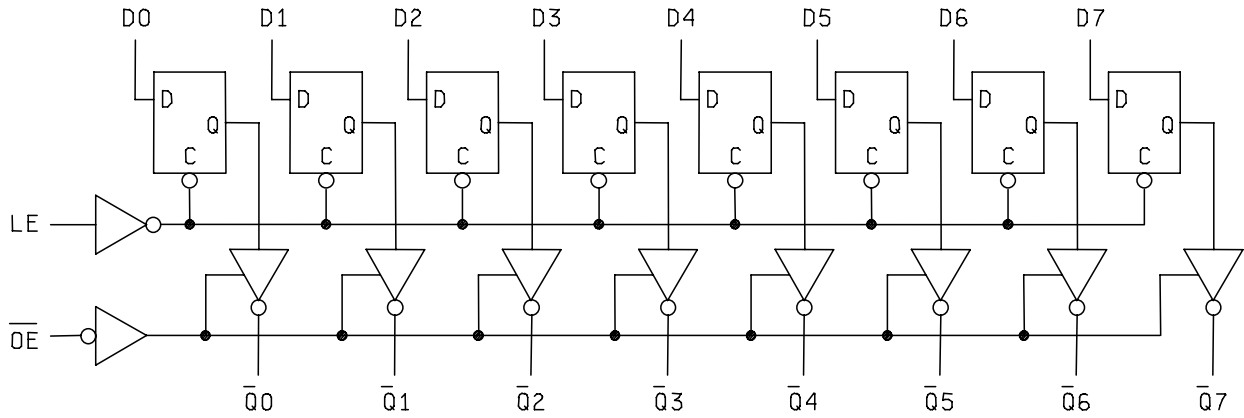

FIGURE 2. Logic diagrams.

DEVICE TYPE 03



DEVICE TYPE 04

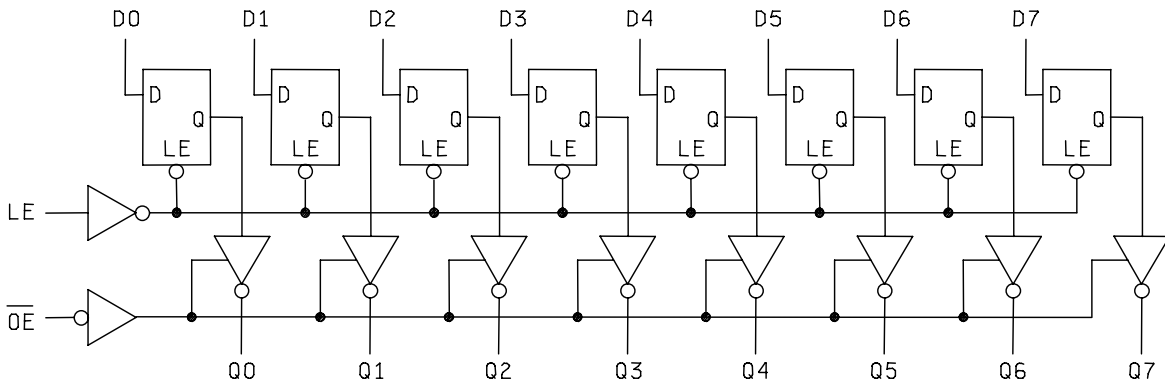

FIGURE 2. Logic diagrams - Continued.

Device type 01 and 04

Inputs				Outputs	
\overline{OE}	Dn	LE		Qn	
		t	t+1	t	t+1
H	X	X	X	Z	Z
L	H	H	H	H	H
L	L	H	H	L	L
L	H	H	L	H	H
L	L	H	L	L	L
L	X	L	L	Q0	Q0
L	H	L	H	Q0	H
L	L	L	H	Q0	L

Device type 02

Inputs				Outputs	
\overline{OE}	Dn	LE		$\overline{Q}n$	
		t	t+1	t	t+1
H	X	X	X	Z	Z
L	H	H	H	L	L
L	L	H	H	H	H
L	H	H	L	L	L
L	L	H	L	H	H
L	X	L	L	Q0	Q0
L	H	L	H	Q0	L
L	L	L	H	Q0	H

H = HIGH voltage level
 L = LOW voltage level
 X = Immaterial
 Z = High impedance
 Q0 = Output prior to last H to L transition of LE

FIGURE 3. Truth tables.

Device type 03

Inputs			Internal	Output	Function
\overline{OE}	LE	D	Q	0	
H	X	X	X	Z	High Z
H	H	L	H	Z	High Z
H	H	H	L	Z	High Z
H	L	X	NC	Z	Latched
L	H	L	H	H	Transparent
L	H	H	L	L	Transparent
L	L	X	NC	NC	Latched

H = HIGH voltage level
 L = LOW voltage level
 X = Immaterial
 Z = High impedance
 NC = No change

FIGURE 3. Truth tables - Continued.

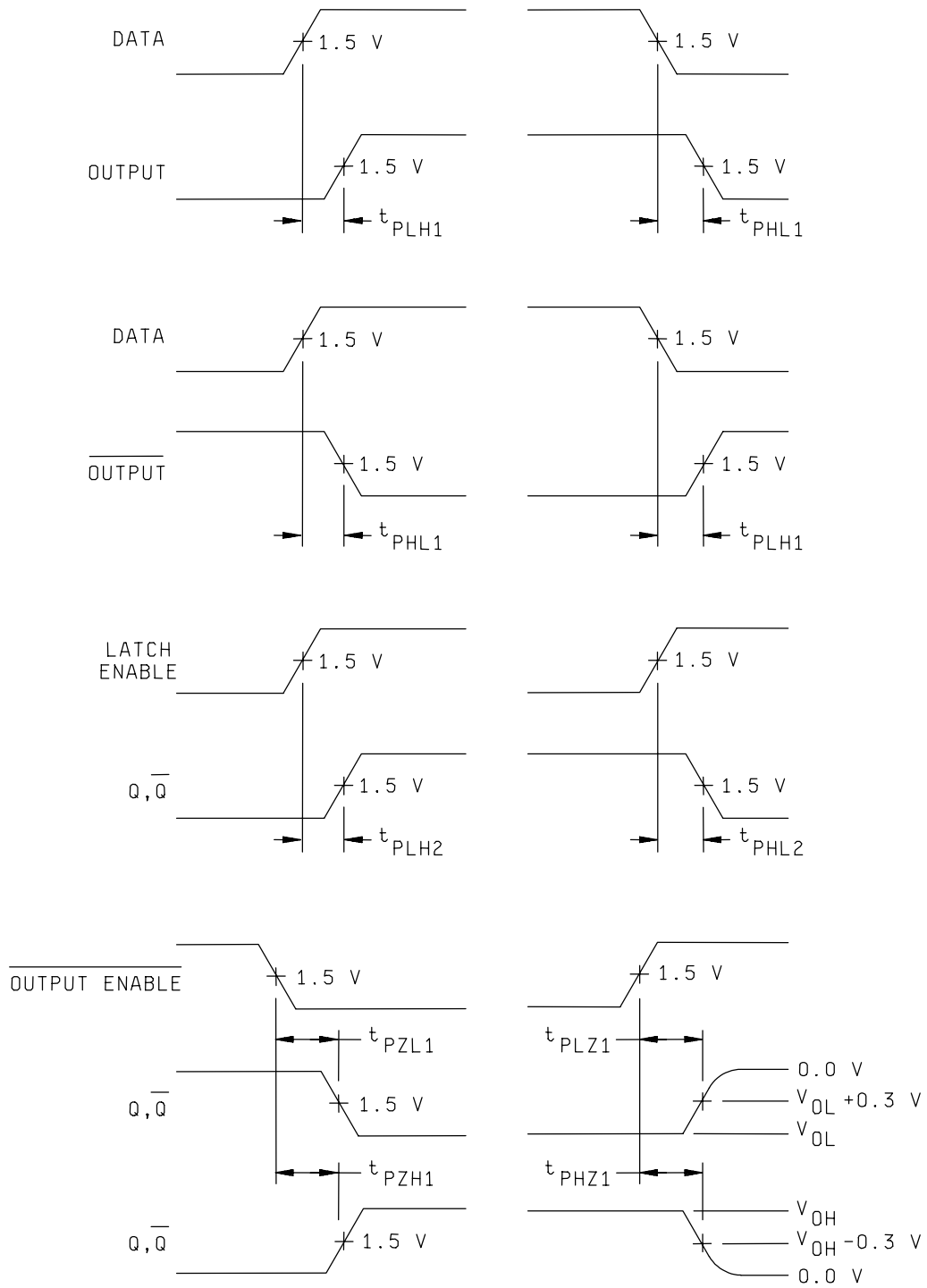
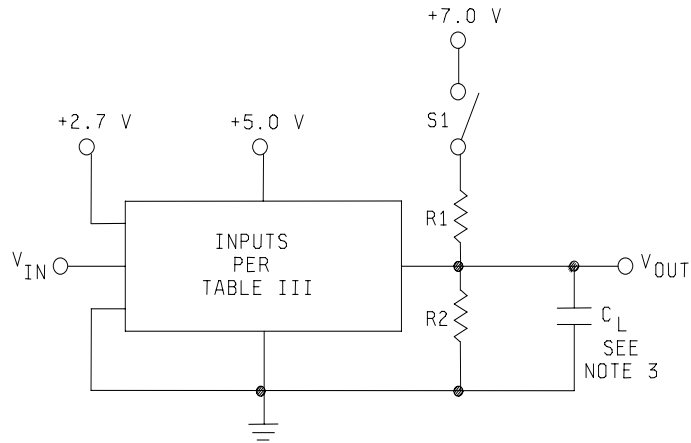
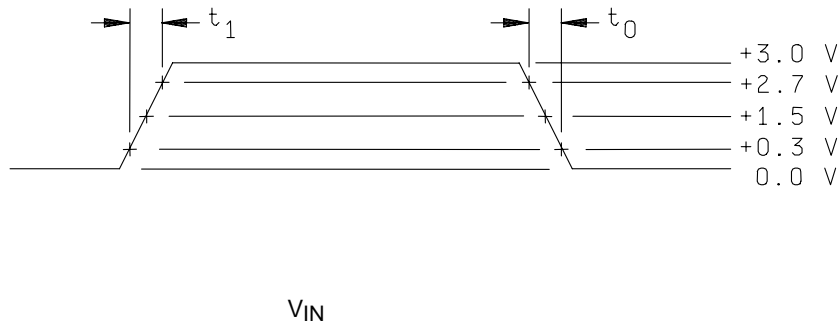

FIGURE 4. Switching time waveforms.



TEST TYPE	S1
t_{PLH}	OPEN
t_{PHL}	OPEN
t_{PHZ}	OPEN
t_{PZH}	OPEN
t_{PLZ}	CLOSED
t_{PZL}	CLOSED



NOTES:

1. Input has the following characteristics: $t_1 = t_0 \leq 2.5$ ns, $PRR \leq 1$ MHz, $Z_{OUT} \cong 50\Omega$.
2. Inputs not under test are at ground.
3. $C_L = 50$ pF $\pm 10\%$ including scope, probe, wiring, and stray capacitance without package in test fixture.
4. R_1 and $R_2 = 499\Omega \pm 5\%$.
5. Voltage measurements are to be made with respect to network ground terminal.

FIGURE 4. Switching time test circuits - Continued.

TABLE III. Group A inspection for device type 01.
Terminal conditions (pins not designated may be high ≥ 2.0 V; low ≤ 0.8 V; or open).

Subgroup	Symbol	MIL-STD-883 method	Cases R.S.X.2 Test no.	1	2	3	4	5	6	7	8	9	10	11	12	13	14	15	16	17	18	19	20	Measured terminal	Test limits		Unit			
				OE	Q0	D0	D1	Q1	Q2	D2	D3	Q3	GND	LE	Q4	D4	D5	Q5	Q6	D6	D7	Q7	V _{CC}		Min	Max				
1 T _c = 25°C	V _{OH}	3006	1	0.8 V	-1 mA	2.0 V	2.0 V	2.0 V	-1 mA															Q0	2.5		V			
			2	"	"	"	"	"	"	"	"	"	"	"	"	"	"	"	"	"	"	"	"	"	Q1	"	"	"		
			3	"	"	"	"	"	"	"	"	"	"	"	"	"	"	"	"	"	"	"	"	"	"	Q2	"	"	"	
			4	"	"	"	"	"	"	"	"	"	"	"	"	"	"	"	"	"	"	"	"	"	"	Q3	"	"	"	
			5	"	"	"	"	"	"	"	"	"	"	"	"	"	"	"	"	"	"	"	"	"	"	Q4	"	"	"	
			6	"	"	"	"	"	"	"	"	"	"	"	"	"	"	"	"	"	"	"	"	"	"	"	Q5	"	"	"
			7	"	"	"	"	"	"	"	"	"	"	"	"	"	"	"	"	"	"	"	"	"	"	"	Q6	"	"	"
			8	"	"	"	"	"	"	"	"	"	"	"	"	"	"	"	"	"	"	"	"	"	"	"	Q7	"	"	"
	V _{OL}	3007	9	"	20 mA	0.8 V	0.8 V	20 mA	20 mA																G0		0.5	"		
			10	"	"	"	"	"	"	"	"	"	"	"	"	"	"	"	"	"	"	"	"	"	"	Q1	"	"	"	
			11	"	"	"	"	"	"	"	"	"	"	"	"	"	"	"	"	"	"	"	"	"	"	Q2	"	"	"	
			12	"	"	"	"	"	"	"	"	"	"	"	"	"	"	"	"	"	"	"	"	"	"	Q3	"	"	"	
			13	"	"	"	"	"	"	"	"	"	"	"	"	"	"	"	"	"	"	"	"	"	"	Q4	"	"	"	
			14	"	"	"	"	"	"	"	"	"	"	"	"	"	"	"	"	"	"	"	"	"	"	"	Q5	"	"	"
			15	"	"	"	"	"	"	"	"	"	"	"	"	"	"	"	"	"	"	"	"	"	"	"	Q6	"	"	"
	V _{IC}		16	"	"	"	"	"	"	"	"	"	"	"	"	"	"	"	"	"	"	"	"	"	"	Q7	"	"	"	
			17	"	-18 mA	"	"	"	"	"	"	"	"	"	"	"	"	"	"	"	"	"	"	"	"	OE	"	-1.2	"	
18			"	"	-18 mA	"	"	"	"	"	"	"	"	"	"	"	"	"	"	"	"	"	"	"	OE	"	"	"		
I _{H1}	3010	19	"	"	"	-18 mA	"	"	"	"	"	"	"	"	"	"	"	"	"	"	"	"	"	"	D0	"	"	"		
		20	"	"	"	"	"	"	"	"	"	"	"	"	"	"	"	"	"	"	"	"	"	"	D1	"	"	"		
		21	"	"	"	"	"	"	"	"	"	"	"	"	"	"	"	"	"	"	"	"	"	"	"	D2	"	"	"	
		22	"	"	"	"	"	"	"	"	"	"	"	"	"	"	"	"	"	"	"	"	"	"	"	"	D3	"	"	"
		23	"	"	"	"	"	"	"	"	"	"	"	"	"	"	"	"	"	"	"	"	"	"	"	"	LE	"	"	"
		24	"	"	"	"	"	"	"	"	"	"	"	"	"	"	"	"	"	"	"	"	"	"	"	"	D4	"	"	"
		25	"	"	"	"	"	"	"	"	"	"	"	"	"	"	"	"	"	"	"	"	"	"	"	"	D5	"	"	"
		26	"	"	"	"	"	"	"	"	"	"	"	"	"	"	"	"	"	"	"	"	"	"	"	"	D6	"	"	"
		27	"	"	"	"	"	"	"	"	"	"	"	"	"	"	"	"	"	"	"	"	"	"	"	"	D7	"	"	"
		28	"	"	"	"	"	"	"	"	"	"	"	"	"	"	"	"	"	"	"	"	"	"	"	"	OE	"	20	μA
I _{H2}		29	"	"	"	"	2.7 V	"	"	"	"	"	"	"	"	"	"	"	"	"	"	"	"	"	D0	"	"	"		
		30	"	"	"	"	"	2.7 V	"	"	"	"	"	"	"	"	"	"	"	"	"	"	"	"	D1	"	"	"		
		31	"	"	"	"	"	"	"	"	"	"	"	"	"	"	"	"	"	"	"	"	"	"	"	D2	"	"	"	
		32	"	"	"	"	"	"	"	"	"	"	"	"	"	"	"	"	"	"	"	"	"	"	"	D3	"	"	"	
		33	"	"	"	"	"	"	"	"	"	"	"	"	"	"	"	"	"	"	"	"	"	"	"	"	LE	"	"	"
		34	"	"	"	"	"	"	"	"	"	"	"	"	"	"	"	"	"	"	"	"	"	"	"	"	D4	"	"	"
		35	"	"	"	"	"	"	"	"	"	"	"	"	"	"	"	"	"	"	"	"	"	"	"	"	D5	"	"	"
		36	"	"	"	"	"	"	"	"	"	"	"	"	"	"	"	"	"	"	"	"	"	"	"	"	D6	"	"	"
		37	"	"	"	"	"	"	"	"	"	"	"	"	"	"	"	"	"	"	"	"	"	"	"	D7	"	"	"	
		38	"	"	"	"	"	"	"	"	"	"	"	"	"	"	"	"	"	"	"	"	"	"	"	OE	"	100	"	
		39	"	"	"	"	"	"	"	"	"	"	"	"	"	"	"	"	"	"	"	"	"	"	"	D0	"	"	"	
		40	"	"	"	"	"	"	"	"	"	"	"	"	"	"	"	"	"	"	"	"	"	"	"	D1	"	"	"	
		41	"	"	"	"	"	"	"	"	"	"	"	"	"	"	"	"	"	"	"	"	"	"	"	"	D2	"	"	"
		42	"	"	"	"	"	"	"	"	"	"	"	"	"	"	"	"	"	"	"	"	"	"	"	"	D3	"	"	"
		43	"	"	"	"	"	"	"	"	"	"	"	"	"	"	"	"	"	"	"	"	"	"	"	"	LE	"	"	"
44	"	"	"	"	"	"	"	"	"	"	"	"	"	"	"	"	"	"	"	"	"	"	"	"	"	D4	"	"	"	
45	"	"	"	"	"	"	"	"	"	"	"	"	"	"	"	"	"	"	"	"	"	"	"	"	"	D5	"	"	"	
46	"	"	"	"	"	"	"	"	"	"	"	"	"	"	"	"	"	"	"	"	"	"	"	"	"	D6	"	"	"	
																									"	D7	"	"	"	
																									"	D7	"	"	"	

See footnotes at end of device type 01.

TABLE III. Group A inspection for device type 01.
Terminal conditions (pins not designated may be high ≥ 2.0 V; low ≤ 0.8 V; or open).

Subgroup	Symbol	MIL-STD-883 R.S.X.2 method	Cases Test no.	Terminal conditions (pins not designated may be high ≥ 2.0 V; low ≤ 0.8 V; or open).																Measured terminal	Test limits		Unit																	
				1	2	3	4	5	6	7	8	9	10	11	12	13	14	15	16		17	18		19	20	Min	Max													
1	I_{IL}	3009	47	0.5 V																					OE	4/	4/	mA												
			48	0.5 V																																				
			49	0.5 V																																				
			50	0.5 V																																				
			51	0.5 V																																				
			52	0.5 V																																				
			53	0.5 V																																				
			54	0.5 V																																				
			55	0.5 V																																				
2	I_{OZH}	3011	57	2.0 V	2.4 V	0.0 V																																		
			58	0.0 V																																				
			59	0.0 V	2.4 V																																			
			60	0.0 V																																				
			61	0.0 V	2.4 V																																			
			62	0.0 V																																				
			63	0.0 V																																				
			64	0.0 V																																				
			65	0.5 V	5.5 V																																			
			66	0.5 V																																				
			67	0.5 V	5.5 V																																			
			68	0.5 V																																				
			69	0.5 V																																				
70	0.5 V																																							
71	0.5 V																																							
3	I_{OS}	3011	72	0.0 V	0.0 V	4.5 V																																		
			73	0.0 V																																				
			74	4.5 V																																				
			75	0.0 V	4.5 V																																			
			76	0.0 V	4.5 V	0.0 V																																		
			77	0.0 V																																				
			78	0.0 V																																				
			79	0.0 V																																				
			80	2.5 V	0.0 V																																			
			81	2.5 V																																				
			82	2.5 V																																				
			83	2.5 V																																				
84	2.5 V																																							
85	2.5 V																																							
86	2.5 V																																							
87	2.5 V																																							
88	2.5 V																																							
89	0.0 V																																							
90	5.5 V																																							
91	5.5 V																																							

2 Same tests, terminal conditions, and limits as subgroup 1, except $T_C = +125^\circ\text{C}$ and V_{IC} tests are omitted.
3 Same tests, terminal conditions, and limits as subgroup 1, except $T_C = -55^\circ\text{C}$ and V_{IC} tests are omitted.

See footnotes at end of device type 01.

TABLE III. Group A inspection for device type 01.
Terminal conditions (pins not designated may be high ≥ 2.0 V; low ≤ 0.8 V; or open).

Subgroup	Symbol	MIL-STD-883 R.S.X.2 Test no.	Cases	1	2	3	4	5	6	7	8	9	10	11	12	13	14	15	16	17	18	19	20	Test limits		Unit												
																								Measured terminal	Min		Max											
7	Tc = 25°C	3014	92	OE	L	B	A	H	L	H	A	H	GND	LE	L	B	A	H	L	H	L	B	A	H	3/	All												
				B	H	A	B	L	A	B	L	A	B	A	B	A	B	A	B	A	B	A	B	A	B	A	B	L	outputs									
				"	"	A	B	"	A	B	"	"	"	"	"	"	"	"	"	"	"	"	"	"	"	"	"	"	"	"	"	"						
				"	"	"	B	A	"	B	A	"	"	"	"	"	"	"	"	"	"	"	"	"	"	"	"	"	"	"	"	"	"					
				"	"	"	L	B	A	H	L	A	H	A	H	A	A	L	B	A	H	L	A	H	L	B	A	H	"	"	"	"	"	"				
				"	"	"	H	A	B	A	L	H	L	A	B	A	A	L	B	A	H	L	A	H	L	B	A	H	"	"	"	"	"	"	"			
				"	"	"	L	B	A	H	L	A	H	A	H	A	A	L	B	A	H	L	A	H	L	B	A	H	"	"	"	"	"	"	"	"		
				"	"	"	"	"	B	A	"	"	"	"	"	"	"	"	"	"	"	"	"	"	"	"	"	"	"	"	"	"	"	"	"	"	"	
				"	"	"	"	"	A	B	"	"	"	"	"	"	"	"	"	"	"	"	"	"	"	"	"	"	"	"	"	"	"	"	"	"	"	"
				"	"	"	"	"	"	"	"	"	"	"	"	"	"	"	"	"	"	"	"	"	"	"	"	"	"	"	"	"	"	"	"	"	"	"
8	Same tests, terminal conditions, and limits as for subgroup 7, except Tc = +125°C and Tc = -55°C.	3003 Fig. 4	101	0.0 V	OUT	IN							GND	2.7 V									5.0 V	D0 to Q0	3.0	7.0	ns											
				102	"	"	IN	OUT																		D1 to Q1	"	"	"	"	"							
				103	"	"						OUT	IN	OUT														D2 to Q2	"	"	"	"	"	"				
				104	"	"												OUT	IN									D3 to Q3	"	"	"	"	"	"	"			
				105	"	"																OUT	IN	OUT					D4 to Q4	"	"	"	"	"	"	"		
				106	"	"																							D5 to Q5	"	"	"	"	"	"	"		
				107	"	"																	OUT	IN	OUT					D6 to Q6	"	"	"	"	"	"	"	
				108	"	"																							D7 to Q7	"	"	"	"	"	"	"	"	
				109	"	"	OUT	IN																		OUT				D0 to Q0	2.0	5.0						
				110	"	"				IN	OUT																		D1 to Q1	"	"	"	"	"	"	"	"	
				111	"	"						OUT	IN																	D2 to Q2	"	"	"	"	"	"	"	"
				112	"	"																								D3 to Q3	"	"	"	"	"	"	"	"
				113	"	"													OUT	IN										D4 to Q4	"	"	"	"	"	"	"	"
				114	"	"																								D5 to Q5	"	"	"	"	"	"	"	"
115	"	"																								D6 to Q6	"	"	"	"	"	"	"	"				
116	"	"																								D7 to Q7	"	"	"	"	"	"	"	"				
117	"	"	OUT	2.7 V	OUT	2.7 V	OUT	2.7 V	OUT	2.7 V	OUT	2.7 V	IN													LE to Q0	5.0	11.5										
118	"	"																								LE to Q1	"	"	"	"	"	"	"	"				
119	"	"																								LE to Q2	"	"	"	"	"	"	"	"				
120	"	"																								LE to Q3	"	"	"	"	"	"	"	"				
121	"	"													OUT	2.7 V										LE to Q4	"	"	"	"	"	"	"	"				
122	"	"																								LE to Q5	"	"	"	"	"	"	"	"				
123	"	"																								LE to Q6	"	"	"	"	"	"	"	"				
124	"	"																								LE to Q7	"	"	"	"	"	"	"	"				
125	"	"																		OUT	2.7 V	OUT				LE to Q0	3.0	7.0										
126	"	"																								LE to Q1	"	"	"	"	"	"	"	"				
127	"	"																								LE to Q2	"	"	"	"	"	"	"	"				
128	"	"																								LE to Q3	"	"	"	"	"	"	"	"				
129	"	"													OUT	0.0 V										LE to Q4	"	"	"	"	"	"	"	"				
130	"	"																								LE to Q5	"	"	"	"	"	"	"	"				
131	"	"																								LE to Q6	"	"	"	"	"	"	"	"				
132	"	"																								LE to Q7	"	"	"	"	"	"	"	"				
133	"	"	IN	OUT	2.7 V	2.7 V	OUT	2.7 V	OUT	2.7 V	OUT	2.7 V	2.7 V													OE to Q0	1.5	6.5										
134	"	"																								OE to Q1	"	"	"	"	"	"	"	"				
135	"	"																								OE to Q2	"	"	"	"	"	"	"	"				
136	"	"																								OE to Q3	"	"	"	"	"	"	"	"				
137	"	"																								OE to Q4	"	"	"	"	"	"	"	"				
138	"	"																								OE to Q5	"	"	"	"	"	"	"	"				
139	"	"																								OE to Q6	"	"	"	"	"	"	"	"				
140	"	"																								OE to Q7	"	"	"	"	"	"	"	"				

See footnotes at end of device type 01.

TABLE III. Group A inspection for device type 01.
Terminal conditions (pins not designated may be high ≥ 2.0 V; low ≤ 0.8 V; or open).

Subgroup	Symbol	MIL-STD-883 method	Cases R.S.X.2 Test no.	1	2	3	4	5	6	7	8	9	10	11	12	13	14	15	16	17	18	19	20	Measured terminal	Test limits		Unit			
				OE	Q0	D0	D1	Q1	Q2	D2	D3	Q3	GND	LE	Q4	D4	D5	Q5	Q6	D6	D7	Q7	V _{cc}		Min	Max				
9	T _c = 25°C	3003 Fig. 4	141	IN	OUT	0.0 V	0.0 V	OUT	0.0 V	OUT	0.0 V	0.0 V	OUT	GND	2.7 V									5.0 V	OE to Q0	1.5	6.5	ns		
			142	"	"	"	0.0 V	OUT							"	"								"	OE to Q1	"	"	"		
			143	"	"	"									"	"									"	OE to Q2	"	"	"	
			144	"	"	"									"	"									"	OE to Q3	"	"	"	
			145	"	"	"									"	"	OUT	0.0 V							"	OE to Q4	"	"	"	
			146	"	"	"									"	"			0.0 V	OUT					"	OE to Q5	"	"	"	
			147	"	"	"									"	"				OUT	0.0 V				"	OE to Q6	"	"	"	
			148	"	"	"									"	"								0.0 V	OUT	"	OE to Q7	"	"	"
			149	"	"	"	OUT	2.7 V							"	"									"	OE to Q0	2.0	11.0	"	
			150	"	"	"				2.7 V	OUT				"	"									"	OE to Q1	"	"	"	
			151	"	"	"					OUT	2.7 V			"	"									"	OE to Q2	"	"	"	
			152	"	"	"							2.7 V	OUT		"	"								"	OE to Q3	"	"	"	
			153	"	"	"										"	"	OUT	2.7 V						"	OE to Q4	"	"	"	
			154	"	"	"										"	"			2.7 V	OUT				"	OE to Q5	"	"	"	
155	"	"	"										"	"				OUT	2.7 V			"	OE to Q6	"	"	"				
156	"	"	"										"	"								"	OE to Q7	"	"	"				
157	"	"	"	OUT	0.0 V							"	"									2.7 V	OUT	"	OE to Q7	"	"	"		
158	"	"	"				0.0 V	OUT				"	"										5.0 V	OE to Q0	"	7.5	"			
159	"	"	"						OUT	0.0 V		"	"										"	OE to Q1	"	"	"			
160	"	"	"								0.0 V	OUT	"	"									"	OE to Q2	"	"	"			
161	"	"	"										"	"	OUT	0.0 V						"	OE to Q3	"	"	"				
162	"	"	"										"	"			0.0 V	OUT				"	OE to Q4	"	"	"				
163	"	"	"										"	"					OUT	0.0 V		"	OE to Q5	"	"	"				
164	"	"	"										"	"						OUT	0.0 V		"	OE to Q6	"	"	"			
164	"	"	"										"	"							0.0 V	OUT	"	OE to Q7	"	"	"			
10	Same tests as subgroup 9, except T _c = +125°C and use limits from table I.																													
11	Same tests as subgroup 10, except T _c = -55°C and use limits from table I.																													

- 1/ A ≥ 2.5 V, B ≤ 0.5 V.
- 2/ H ≥ 1.5 V, L ≤ 1.5 V.
- 3/ Perform subgroup 7 sequence at V_{cc} = 4.5 V and repeat at V_{cc} = 5.5 V.
- 4/ I_L limits (mA) min/max values for circuit shown:

Parameter	Circuits			
	A	B	C	D
I _L	-0.25/-60	-0.03/-60	-0.03/-60	0.0/-30

TABLE III. Group A inspection for device type 02.
Terminal conditions (pins not designated may be high ≥ 2.0 V; low ≤ 0.8 V; or open).

Subgroup	Symbol	MIL-STD-883 R.S.X.2 method	Cases Test.no.	Terminal conditions (pins not designated may be high ≥ 2.0 V; low ≤ 0.8 V; or open).																	Measured terminal	Test limits		Unit										
				1	2	3	4	5	6	7	8	9	10	11	12	13	14	15	16	17		18	19		20	Min	Max							
1	V_{OH}	3006	1	0.8 V	OE	Q 0	-1 mA	0.8 V	D0	D1	Q 1	Q 2	D2	D3	Q 3	GND	LE	Q 4	D4	D5	Q 5	Q 6	D6	D7	Q 7	4.5 V	Q 0	2.5		V				
			2	"	"	"	"	"	"	"	"	"	"	"	"	"	"	"	"	"	"	"	"	"	"	"	"	"	Q 1	"	"	"		
			3	"	"	"	"	"	"	"	"	"	"	"	"	"	"	"	"	"	"	"	"	"	"	"	"	"	"	Q 2	"	"	"	
			4	"	"	"	"	"	"	"	"	"	"	"	"	"	"	"	"	"	"	"	"	"	"	"	"	"	"	"	Q 3	"	"	"
			5	"	"	"	"	"	"	"	"	"	"	"	"	"	"	"	"	"	"	"	"	"	"	"	"	"	"	"	Q 4	"	"	"
			6	"	"	"	"	"	"	"	"	"	"	"	"	"	"	"	"	"	"	"	"	"	"	"	"	"	"	"	Q 5	"	"	"
			7	"	"	"	"	"	"	"	"	"	"	"	"	"	"	"	"	"	"	"	"	"	"	"	"	"	"	"	Q 6	"	"	"
			8	"	"	"	"	"	"	"	"	"	"	"	"	"	"	"	"	"	"	"	"	"	"	"	"	"	"	"	Q 7	"	"	"
			9	"	"	"	"	"	"	"	"	"	"	"	"	"	"	"	"	"	"	"	"	"	"	"	"	"	"	"	Q 0	"	"	"
			10	"	"	"	"	"	"	"	"	"	"	"	"	"	"	"	"	"	"	"	"	"	"	"	"	"	"	"	Q 1	"	"	"
			11	"	"	"	"	"	"	"	"	"	"	"	"	"	"	"	"	"	"	"	"	"	"	"	"	"	"	"	Q 2	"	"	"
			12	"	"	"	"	"	"	"	"	"	"	"	"	"	"	"	"	"	"	"	"	"	"	"	"	"	"	"	Q 3	"	"	"
			13	"	"	"	"	"	"	"	"	"	"	"	"	"	"	"	"	"	"	"	"	"	"	"	"	"	"	"	Q 4	"	"	"
			14	"	"	"	"	"	"	"	"	"	"	"	"	"	"	"	"	"	"	"	"	"	"	"	"	"	"	"	Q 5	"	"	"
			15	"	"	"	"	"	"	"	"	"	"	"	"	"	"	"	"	"	"	"	"	"	"	"	"	"	"	"	Q 6	"	"	"
			16	"	"	"	"	"	"	"	"	"	"	"	"	"	"	"	"	"	"	"	"	"	"	"	"	"	"	"	Q 7	"	"	"
				V_{OL}	3007	9	"	"	"	"	"	"	"	"	"	"	"	"	"	"	"	"	"	"	"	"	"	"	"	"	"	Q 0	"	"
10	"	"				"	"	"	"	"	"	"	"	"	"	"	"	"	"	"	"	"	"	"	"	"	"	"	Q 1	"	"	"		
11	"	"				"	"	"	"	"	"	"	"	"	"	"	"	"	"	"	"	"	"	"	"	"	"	"	"	Q 2	"	"	"	
12	"	"				"	"	"	"	"	"	"	"	"	"	"	"	"	"	"	"	"	"	"	"	"	"	"	"	Q 3	"	"	"	
13	"	"				"	"	"	"	"	"	"	"	"	"	"	"	"	"	"	"	"	"	"	"	"	"	"	"	Q 4	"	"	"	
14	"	"				"	"	"	"	"	"	"	"	"	"	"	"	"	"	"	"	"	"	"	"	"	"	"	"	Q 5	"	"	"	
15	"	"				"	"	"	"	"	"	"	"	"	"	"	"	"	"	"	"	"	"	"	"	"	"	"	"	Q 6	"	"	"	
16	"	"				"	"	"	"	"	"	"	"	"	"	"	"	"	"	"	"	"	"	"	"	"	"	"	"	Q 7	"	"	"	
17	"	"				"	"	"	"	"	"	"	"	"	"	"	"	"	"	"	"	"	"	"	"	"	"	"	"	"	Q 0	"	"	"
18	"	"				"	"	"	"	"	"	"	"	"	"	"	"	"	"	"	"	"	"	"	"	"	"	"	"	"	Q 1	"	"	"
19	"	"				"	"	"	"	"	"	"	"	"	"	"	"	"	"	"	"	"	"	"	"	"	"	"	"	"	Q 2	"	"	"
	V_{IC}	3010	17	-18 mA	"	"	"	"	"	"	"	"	"	"	"	"	"	"	"	"	"	"	"	"	"	"	"	"	Q 7	"	"	"		
			18	"	"	"	"	"	"	"	"	"	"	"	"	"	"	"	"	"	"	"	"	"	"	"	"	"	OE	"	"	"		
			19	"	"	"	"	"	"	"	"	"	"	"	"	"	"	"	"	"	"	"	"	"	"	"	"	"	"	D0	"	"	"	
			20	"	"	"	"	"	"	"	"	"	"	"	"	"	"	"	"	"	"	"	"	"	"	"	"	"	"	D1	"	"	"	
			21	"	"	"	"	"	"	"	"	"	"	"	"	"	"	"	"	"	"	"	"	"	"	"	"	"	"	"	D2	"	"	"
			22	"	"	"	"	"	"	"	"	"	"	"	"	"	"	"	"	"	"	"	"	"	"	"	"	"	"	"	D3	"	"	"
			23	"	"	"	"	"	"	"	"	"	"	"	"	"	"	"	"	"	"	"	"	"	"	"	"	"	"	"	LE	"	"	"
			24	"	"	"	"	"	"	"	"	"	"	"	"	"	"	"	"	"	"	"	"	"	"	"	"	"	"	"	D4	"	"	"
			25	"	"	"	"	"	"	"	"	"	"	"	"	"	"	"	"	"	"	"	"	"	"	"	"	"	"	"	D5	"	"	"
			26	"	"	"	"	"	"	"	"	"	"	"	"	"	"	"	"	"	"	"	"	"	"	"	"	"	"	"	D6	"	"	"
	I_{H1}	3010	27	2.7 V	"	"	"	"	"	"	"	"	"	"	"	"	"	"	"	"	"	"	"	"	"	"	"	"	D7	"	"	"		
			28	"	"	"	"	"	"	"	"	"	"	"	"	"	"	"	"	"	"	"	"	"	"	"	"	"	OE	"	"	"		
			29	"	"	"	"	"	"	"	"	"	"	"	"	"	"	"	"	"	"	"	"	"	"	"	"	"	"	D0	"	"	"	
			30	"	"	"	"	"	"	"	"	"	"	"	"	"	"	"	"	"	"	"	"	"	"	"	"	"	"	D1	"	"	"	
			31	"	"	"	"	"	"	"	"	"	"	"	"	"	"	"	"	"	"	"	"	"	"	"	"	"	"	D2	"	"	"	
			32	"	"	"	"	"	"	"	"	"	"	"	"	"	"	"	"	"	"	"	"	"	"	"	"	"	"	D3	"	"	"	
			33	"	"	"	"	"	"	"	"	"	"	"	"	"	"	"	"	"	"	"	"	"	"	"	"	"	"	LE	"	"	"	
			34	"	"	"	"	"	"	"	"	"	"	"	"	"	"	"	"	"	"	"	"	"	"	"	"	"	"	D4	"	"	"	
			35	"	"	"	"	"	"	"	"	"	"	"	"	"	"	"	"	"	"	"	"	"	"	"	"	"	"	D5	"	"	"	
			36	"	"	"	"	"	"	"	"	"	"	"	"	"	"	"	"	"	"	"	"	"	"	"	"	"	"	"	D6	"	"	"
			37	"	"	"	"	"	"	"	"	"	"	"	"	"	"	"	"	"	"	"	"	"	"	"	"	"	"	"	D7	"	"	"
				I_{H2}	3010	37	7.0 V	"	"	"	"	"	"	"	"	"	"	"	"	"	"	"	"	"	"	"	"	"	"	"	"	OE	"	"
38	"	"				"	"	"	"	"	"	"	"	"	"	"	"	"	"	"	"	"	"	"	"	"	"	"	D0	"	"	"		
39	"	"				"	"	"	"	"	"	"	"	"	"	"	"	"	"	"	"	"	"	"	"	"	"	"	"	D1	"	"	"	
40	"	"				"	"	"	"	"	"	"	"	"	"	"	"	"	"	"	"	"	"	"	"	"	"	"	"	D2	"	"	"	
41	"	"				"	"	"	"	"	"	"	"	"	"	"	"	"	"	"	"	"	"	"	"	"	"	"	"	D3	"	"	"	
42	"	"				"	"	"	"	"	"	"	"	"	"	"	"	"	"	"	"	"	"	"	"	"	"	"	"	LE	"	"	"	
43	"	"				"	"	"	"	"	"	"	"	"	"	"	"	"	"	"	"	"	"	"	"	"	"	"	"	D4	"	"	"	
44	"	"				"	"	"	"	"	"	"	"	"	"	"	"	"	"	"	"	"	"	"	"	"	"	"	"	D5	"	"	"	
45	"	"	"	"	"	"	"	"	"	"	"	"	"	"	"	"	"	"	"	"	"	"	"	"	"	"	D6	"	"	"				
46	"	"	"	"	"	"	"	"	"	"	"	"	"	"	"	"	"	"	"	"	"	"	"	"	"	"	"	D7	"	"	"			

See footnotes at end of device type 02.

TABLE III. Group A inspection for device type 02.
Terminal conditions (pins not designated may be high $\geq 2.0\text{ V}$; low $\leq 0.8\text{ V}$; or open).

Subgroup	Symbol	MIL-STD-883 R.S.X.2 method	Cases Test.no.	Terminal conditions (pins not designated may be high $\geq 2.0\text{ V}$; low $\leq 0.8\text{ V}$; or open)																Measured terminal	Test limits		Unit														
				1	2	3	4	5	6	7	8	9	10	11	12	13	14	15	16		17	18		19	20	Min	Max										
1	I_{IL}	3009	47	OE	Q 0	D0	D1	Q 1	Q 2	D2	D3	Q 3	GND	LE	Q 4	D4	D5	Q 5	Q 6	D6	D7	Q 7	V _{CC}	OE	4/	4/	mA										
			48	0.5 V									0.5 V																								
Tc = 25°C		"	49			0.5 V																															
			50						0.5 V																												
			51									0.5 V																									
			52												0.5 V																						
			53															0.5 V																			
			54															0.5 V																			
			55																0.5 V																		
			56																				0.5 V														
			57			2.0 V	2.4 V	5.5 V								5.5 V								0.5 V													
			58			"			5.5 V	2.4 V																	50										
			59			"					2.4 V	5.5 V																									
			60			"							5.5 V	2.4 V																							
			61			"									2.4 V	5.5 V																					
62			"													5.5 V		2.4 V																			
63			"																2.4 V	5.5 V																	
64			"																		5.5 V	2.4 V															
65			"	0.5 V	0.0 V																																
66			"				0.0 V	0.5 V																													
67			"						0.5 V	0.0 V																											
68			"								0.0 V	0.5 V																									
69			"										0.5 V	0.0 V																							
70			"													0.0 V		0.5 V																			
71			"																																		
72			"																																		
73		3011	0.0 V	0.0 V	0.0 V																0.0 V		0.5 V														
74		"					0.0 V	0.0 V																													
75		"							0.0 V	0.0 V																											
76		"									0.0 V	0.0 V																									
77		"											0.0 V	0.0 V																							
78		"																																			
79		"														0.0 V		0.0 V																			
80		"																		0.0 V	0.0 V																

See footnotes at end of device type 02.

TABLE III. Group A inspection for device type 02.
Terminal conditions (pins not designated may be high ≥ 2.0 V; low ≤ 0.8 V; or open).

Subgroup	Symbol	MIL-STD-883 method	Cases R,S,X,2 Test no.	Terminal conditions																	Test limits		Unit									
				1	2	3	4	5	6	7	8	9	10	11	12	13	14	15	16	17	18	19		20	Min	Max						
1 $T_c = 25^\circ\text{C}$	I_{OO}		81	0.0 V	$\bar{Q} 0$	D0	D1	$\bar{Q} 1$	$\bar{Q} 2$	D2	D3	$\bar{Q} 3$	GND	LE	$\bar{Q} 4$	D4	D5	$\bar{Q} 5$	D6	D7	$\bar{Q} 7$	V_{CC}	35		mA							
				5.5 V				5.5 V						5.5 V																		
								2.5 V																								
												2.5 V																				
																					2.5 V											
2			82																													
3			83																													
7 $T_c = 25^\circ\text{C}$	Functional tests 1/ 2/ 3/	3014	92	L	L	A	B	H	L	A	B	A	GND	A	L	A	B	L	A	B	H	A	L	All outputs								
				H	H	A	B	A	L	A		A	H	B	A		B	A	B	H	A	B	A									
8			101	0.0 V	OUT	IN							GND	2.7 V									5.0 V	D0 to $\bar{Q} 0$								
9 $T_c = 25^\circ\text{C}$	t_{PH1}	3003 Fig. 4	102	0.0 V	OUT	IN							GND	2.7 V									5.0 V	D0 to $\bar{Q} 0$								

See footnotes at end of device type 02.

TABLE III. Group A inspection for device type 02.
Terminal conditions (pins not designated may be high ≥ 2.0 V; low ≤ 0.8 V; or open).

Subgroup	Symbol	MIL-STD-883 R.S.X.2 method	Cases Test no.	1	2	3	4	5	6	7	8	9	10	11	12	13	14	15	16	17	18	19	20	Measured terminal	Test limits		Unit		
				OE	\overline{Q} 0	D0	D1	\overline{Q} 1	\overline{Q} 2	D2	D3	\overline{Q} 3	GND	LE	\overline{Q} 4	D4	D5	\overline{Q} 5	\overline{Q} 6	D6	D7	\overline{Q} 7	V _{CC}		Min	Max			
9	t _{PLH2}	3003 Fig. 4	117	0.0 V	OUT	0.0 V		OUT					GND	IN									5.0 V	LE to \overline{Q} 0	5.0	11.0	ns		
			118	"			0.0 V							"	"									"	LE to \overline{Q} 1	"	"	"	
			119	"				0.0 V		OUT				"	"									"	LE to \overline{Q} 2	"	"	"	
			120	"							OUT		0.0 V		"	"								"	LE to \overline{Q} 3	"	"	"	
			121	"										"	"	OUT	0.0 V							"	LE to \overline{Q} 4	"	"	"	
			122	"										"	"		OUT	0.0 V		OUT				"	LE to \overline{Q} 5	"	"	"	
			123	"										"	"						OUT	0.0 V		"	LE to \overline{Q} 6	"	"	"	
			124	"											"	"						OUT	0.0 V		LE to \overline{Q} 7	3.0	7.0	"	
			125	"					2.7 V		OUT				"	"									"	LE to \overline{Q} 0	"	"	"
			126	"						2.7 V		OUT			"	"									"	LE to \overline{Q} 1	"	"	"
			127	"									2.7 V		"	"									"	LE to \overline{Q} 2	"	"	"
			128	"										2.7 V	OUT	"	"								"	LE to \overline{Q} 3	"	"	"
			129	"												"	OUT	2.7 V							"	LE to \overline{Q} 4	"	"	"
130	"												"				2.7 V	OUT				"	LE to \overline{Q} 5	"	"	"			
131	"												"					OUT	2.7 V			"	LE to \overline{Q} 6	"	"	"			
132	"												"								2.7 V	OUT	LE to \overline{Q} 7	"	"	"			
133	"					0.0 V						"	"									"	\overline{OE} to \overline{Q} 0	1.5	6.5	"			
134	"						0.0 V	OUT				"	"									"	\overline{OE} to \overline{Q} 1	"	"	"			
135	"							OUT		0.0 V		"	"									"	\overline{OE} to \overline{Q} 2	"	"	"			
136	"										0.0 V	OUT	"	"								"	\overline{OE} to \overline{Q} 3	"	"	"			
137	"												"	OUT	0.0 V							"	\overline{OE} to \overline{Q} 4	"	"	"			
138	"												"				0.0 V	OUT				"	\overline{OE} to \overline{Q} 5	"	"	"			
139	"												"						OUT	0.0 V		"	\overline{OE} to \overline{Q} 6	"	"	"			
140	"												"								0.0 V	OUT	\overline{OE} to \overline{Q} 7	"	"	"			
141	"												"	IN	OUT	2.7 V						"	\overline{OE} to \overline{Q} 0	"	5.5	"			
142	"												"									"	\overline{OE} to \overline{Q} 1	"	"	"			
143	"												"									"	\overline{OE} to \overline{Q} 2	"	"	"			
144	"												"									"	\overline{OE} to \overline{Q} 3	"	"	"			
145	"												"		OUT	2.7 V						"	\overline{OE} to \overline{Q} 4	"	"	"			
146	"												"				2.7 V	OUT				"	\overline{OE} to \overline{Q} 5	"	"	"			
147	"												"						OUT	2.7 V		"	\overline{OE} to \overline{Q} 6	"	"	"			
148	"												"								2.7 V	OUT	\overline{OE} to \overline{Q} 7	"	"	"			

See footnotes at end of device type 02.

TABLE III. Group A inspection for device type 02.
Terminal conditions (pins not designated may be high ≥ 2.0 V; low ≤ 0.8 V; or open).

Subgroup	Symbol	MIL-STD-883 R.S.X.2 method	Cases Test no.	1	2	3	4	5	6	7	8	9	10	11	12	13	14	15	16	17	18	19	20	Measured terminal	Test limits		Unit				
				OE	IN	OUT	OUT	OUT	OUT	OUT	OUT	OUT	OUT	OUT	OUT	OUT	OUT	OUT	OUT	OUT	OUT	OUT	OUT		OUT	OUT		Min	Max		
9	t_{pZH}	3003 Fig. 4	149	OE	IN	OUT	OUT	0.0 V	OUT	OUT	0.0 V	OUT	GND	LE	2.7 V	Q 4	D4	D5	Q 5	Q 6	D6	D7	Q 7	V _{cc}	5.0 V	OE to Q 0	2.0	10.0	ns		
			150	"	"	"	0.0 V	OUT	"	"	"	"	"	"	"	"	"	"	"	"	"	"	"	"	"	"	OE to Q 1	"	"	"	
			151	"	"	"	"	"	"	"	OUT	"	"	"	"	"	"	"	"	"	"	"	"	"	"	"	OE to Q 2	"	"	"	
			152	"	"	"	"	"	"	"	"	0.0 V	"	OUT	"	"	"	"	"	"	"	"	"	"	"	"	"	OE to Q 3	"	"	"
			153	"	"	"	"	"	"	"	"	"	"	"	"	"	OUT	0.0 V	"	"	"	"	"	"	"	"	"	OE to Q 4	"	"	"
			154	"	"	"	"	"	"	"	"	"	"	"	"	"	"	"	0.0 V	"	OUT	"	"	"	"	"	"	OE to Q 5	"	"	"
			155	"	"	"	"	"	"	"	"	"	"	"	"	"	"	"	"	"	"	OUT	0.0 V	"	"	"	"	OE to Q 6	"	"	"
			156	"	"	"	"	"	"	"	"	"	"	"	"	"	"	"	"	"	"	"	"	0.0 V	OUT	"	"	OE to Q 7	"	"	"
			157	t_{pZL1}	"	"	IN	OUT	2.7 V	"	"	"	"	"	"	"	"	"	"	"	"	"	"	"	"	"	"	OE to Q 0	"	6.5	"
			158	"	"	"	"	"	"	2.7 V	OUT	"	"	"	"	"	"	"	"	"	"	"	"	"	"	"	"	OE to Q 1	"	"	"
			159	"	"	"	"	"	"	"	"	OUT	2.7 V	"	"	"	"	"	"	"	"	"	"	"	"	"	"	OE to Q 2	"	"	"
			160	"	"	"	"	"	"	"	"	"	"	2.7 V	OUT	"	"	"	"	"	"	"	"	"	"	"	"	OE to Q 3	"	"	"
			161	"	"	"	"	"	"	"	"	"	"	"	"	"	"	OUT	2.7 V	"	"	"	"	"	"	"	"	OE to Q 4	"	"	"
			162	"	"	"	"	"	"	"	"	"	"	"	"	"	"	"	"	2.7 V	"	OUT	"	"	"	"	"	OE to Q 5	"	"	"
163	"	"	"	"	"	"	"	"	"	"	"	"	"	"	"	"	"	"	"	OUT	2.7 V	"	"	"	OE to Q 6	"	"	"			
164	"	"	"	"	"	"	"	"	"	"	"	"	"	"	"	"	"	"	"	"	2.7 V	OUT	"	"	OE to Q 7	"	"	"			
10	Same tests as subgroup 9, except T _c = +125°C and use limits from table I.																														
11	Same tests as subgroup 10, except T _c = -55°C and use limits from table I.																														

- 1/ A ≥ 2.5 V, B ≤ 0.5 V.
- 2/ H ≥ 1.5 V, L ≤ 1.5 V.
- 3/ Perform subgroup 7 sequence at V_{cc} = 4.5 V and repeat at V_{cc} = 5.5 V.
- 4/ I_L limits (mA) min/max values for circuit shown:

Parameter	Circuits		
	A	B	C
I _L	-0.25/-0.60	-0.03/-0.60	-0.03/-0.60

TABLE III. Group A inspection for device type 03.
Terminal conditions (pins not designated may be high ≥ 2.0 V; low ≤ 0.8 V; or open).

Subgroup	Symbol	MIL-STD-883 method	Cases R.S.X.2 Test.no.	1	2	3	4	5	6	7	8	9	10	11	12	13	14	15	16	17	18	19	20	Measured terminal	Test limits		Unit				
				OE	D0	D1	D2	D3	D4	D5	D6	D7	GND	LE	Q 7	Q 6	Q 5	Q 4	Q 3	Q 2	Q 1	Q 0	V _{cc}		Min	Max					
1	V _{OH}	3006	1	0.8 V								0.8 V	GND	2.0 V	-1 mA		Q 5	Q 4	Q 3	Q 2	Q 1	Q 0	4.5 V	Q 7	2.5		V				
			2	"							0.8 V	D6	0.8 V	"	"	-1 mA									Q 6	"		"			
			3	"							0.8 V	D5	0.8 V	"	"	-1 mA										Q 5	"		"		
			4	"							0.8 V	D4	0.8 V	"	"	-1 mA										Q 4	"		"		
			5	"						0.8 V	D3	0.8 V	"	"	"	"	-1 mA									Q 3	"		"		
			6	"					0.8 V	D2	0.8 V			"	"	"	"									Q 2	"		"		
			7	"					0.8 V	D1	0.8 V			"	"	"	"									Q 1	"		"		
			8	"					0.8 V	D0	0.8 V			"	"	"	"									Q 0	"		"		
			9	"										2.0 V	"	"	20 mA										Q 7	0.5		"	
			10	"										2.0 V	"	"	20 mA										Q 6	"		"	
			11	"										2.0 V	"	"	"										Q 5	"		"	
			12	"										2.0 V	"	"	"										Q 4	"		"	
			13	"										2.0 V	"	"	"										Q 3	"		"	
			14	"										2.0 V	"	"	"										Q 2	"		"	
			15	"										2.0 V	"	"	"										Q 1	"		"	
			16	"										2.0 V	"	"	"										Q 0	"		"	
V _{OL}	V _{OL}	3007	17	-18 mA									"	"	"									OE	-1.2		"				
			18											"	"	"									D0	"		"			
			19											"	"	"										D1	"		"		
			20											"	"	"										D2	"		"		
			21											"	"	"											D3	"		"	
			22											"	"	"											D4	"		"	
			23											"	"	"											D5	"		"	
			24											"	"	"											D6	"		"	
			25											"	"	"											D7	"		"	
			26											"	"	"											LE	"		"	
I _{H1}	I _{H1}	3010	27	2.7 V									"	"	-18 mA									OE	20		"	μA			
			28											"	"	"									D0	"		"	"		
			29											"	"	"										D1	"		"	"	
			30											"	"	"										D2	"		"	"	
			31											"	"	"											D3	"		"	"
			32											"	"	"											D4	"		"	"
			33											"	"	"											D5	"		"	"
			34											"	"	"											D6	"		"	"
			35											"	"	"											D7	"		"	"
			36											"	"	"											LE	"		"	"
I _{H2}	I _{H2}	3010	37	7.0 V									"	"	2.7 V									OE	100		"	"			
			38											"	"	"									D0	"		"	"		
			39											"	"	"										D1	"		"	"	
			40											"	"	"										D2	"		"	"	
			41											"	"	"											D3	"		"	"
			42											"	"	"											D4	"		"	"
			43											"	"	"											D5	"		"	"
			44											"	"	"											D6	"		"	"
			45											"	"	"											D7	"		"	"
			46											"	"	"											LE	"		"	"

See footnotes at end of device type 03.

TABLE III. Group A inspection for device type 03.
Terminal conditions (pins not designated may be high ≥ 2.0 V; low ≤ 0.8 V; or open).

Subgroup	Symbol	MIL-STD-883 method	Cases R,S,X,2 Test no.	1	2	3	4	5	6	7	8	9	10	11	12	13	14	15	16	17	18	19	20	Test limits		Unit				
				OE	D0	D1	D2	D3	D4	D5	D6	D7	GND	LE	Q 7	Q 6	Q 5	Q 4	Q 3	Q 2	Q 1	Q 0	V _{CC}	Measured terminal	Min		Max			
7 T _c = 25°C	Functional tests 3/	3014	83	B	A	B	A	B	A	B	A	B	A	B	A	H	L	H	L	H	L	H	L	H	L	All outputs				
			84	"	B	A	B	A	B	A	B	A	B	A	B	A	L	H	L	H	L	H	L	H	L	"				
			85	"	B	A	B	A	B	A	B	A	B	A	B	A	L	H	L	H	L	H	L	H	L	"				
			86	"	A	B	A	B	A	B	A	B	A	B	A	B	B	L	H	L	H	L	H	L	H	L	"			
			87	"	A	B	A	B	A	B	A	B	A	B	A	B	A	L	H	L	H	L	H	L	H	L	"			
			88	"	B	A	B	A	B	A	B	A	B	A	B	A	L	H	L	H	L	H	L	H	L	"				
			89	"	A	B	A	B	A	B	A	B	A	B	A	B	"	H	L	H	L	H	L	H	L	"				
			90	"	A	B	A	B	A	B	A	B	A	B	A	B	B	L	H	L	H	L	H	L	H	L	"			
			91	"	B	A	B	A	B	A	B	A	B	A	B	A	B	H	L	H	L	H	L	H	L	"				
			92	0.0 V	IN											GND	2.7 V										D0 to Q 0	3.5	8.5	ns
			9 T _c = 25°C	t _{PH1}	3003 Fig. 4	93	"		IN								"	"						OUT				D1 to Q 1	"	"
94	"						IN								"	"					OUT					D2 to Q 2	"	"	"	
95	"							IN							"	"				OUT						D3 to Q 3	"	"	"	
96	"									IN					"	"				OUT						D4 to Q 4	"	"	"	
97	"									IN					"	"				OUT						D5 to Q 5	"	"	"	
98	"										IN				"	"				OUT						D6 to Q 6	"	"	"	
99	"												IN		"	"				OUT						D7 to Q 7	"	"	"	
100	"	IN													"	"							OUT				D0 to Q 0	2.5	6.5	"
101	"					IN									"	"							OUT				D1 to Q 1	"	"	"
102	"						IN								"	"					OUT						D2 to Q 2	"	"	"
103	"							IN							"	"					OUT						D3 to Q 3	"	"	"
104	"								IN						"	"					OUT						D4 to Q 4	"	"	"
105	"									IN					"	"					OUT						D5 to Q 5	"	"	"
106	"										IN				"	"					OUT						D6 to Q 6	"	"	"
107	"												IN		"	"					OUT						D7 to Q 7	"	"	"
108	"	0.0 V										"	IN								OUT				LE to Q 0	4.5	9.5	"		
109	"		0.0 V									"	"						OUT						LE to Q 1	"	"	"		
110	"			0.0 V								"	"						OUT						LE to Q 2	"	"	"		
111	"				0.0 V							"	"						OUT						LE to Q 3	"	"	"		
112	"					0.0 V						"	"						OUT						LE to Q 4	"	"	"		
113	"						0.0 V					"	"						OUT						LE to Q 5	"	"	"		
114	"							0.0 V				"	"						OUT						LE to Q 6	"	"	"		
115	"								0.0 V			"	"						OUT						LE to Q 7	"	"	"		

See footnotes at end of device type 03.

TABLE III. Group A inspection for device type 03.
Terminal conditions (pins not designated may be high ≥ 2.0 V; low ≤ 0.8 V; or open).

Subgroup	Symbol	MIL-STD-883 R.S.X.2 method	Cases Test no.	1	2	3	4	5	6	7	8	9	10	11	12	13	14	15	16	17	18	19	20	Measured terminal	Test limits		Unit		
				OE	D0	D1	D2	D3	D4	D5	D6	D7	GND	LE	Q 7	Q 6	Q 5	Q 4	Q 3	Q 2	Q 1	Q 0	V _{cc}		Min	Max			
9	t_{PHL2}	3003 Fig. 4	116	0.0 V	2.7 V																			LE to Q 0	3.0	7.0	ns		
			117	"		2.7 V																			LE to Q 1	"	"	"	
			118	"			2.7 V																			LE to Q 2	"	"	"
			119	"				2.7 V																		LE to Q 3	"	"	"
			120	"					2.7 V																	LE to Q 4	"	"	"
			121	"						2.7 V																LE to Q 5	"	"	"
			122	"							2.7 V															LE to Q 6	"	"	"
			123	"								2.7 V														LE to Q 7	"	"	"
			124	"		IN	0.0 V								2.7 V											OE to Q 0	1.5	5.5	"
			125	"		"		0.0 V																		OE to Q 1	"	"	"
			126	"		"			0.0 V																	OE to Q 2	"	"	"
			127	"		"				0.0 V																OE to Q 3	"	"	"
			128	"		"					0.0 V															OE to Q 4	"	"	"
			129	"		"						0.0 V														OE to Q 5	"	"	"
			130	"		"							0.0 V													OE to Q 6	"	"	"
			131	"		"									0.0 V											OE to Q 7	"	"	"
			132	"		"		2.7 V																		OE to Q 0	1.5	5.5	"
133	"		"			2.7 V																	OE to Q 1	"	"	"			
134	"		"				2.7 V																OE to Q 2	"	"	"			
135	"		"					2.7 V															OE to Q 3	"	"	"			
136	"		"						2.7 V														OE to Q 4	"	"	"			
137	"		"							2.7 V													OE to Q 5	"	"	"			
138	"		"								2.7 V												OE to Q 6	"	"	"			
139	"		"									2.7 V											OE to Q 7	"	"	"			
140	"		"		0.0 V																		OE to Q 0	2.0	7.5	"			
141	"		"			0.0 V																	OE to Q 1	"	"	"			
142	"		"				0.0 V																OE to Q 2	"	"	"			
143	"		"					0.0 V															OE to Q 3	"	"	"			
144	"		"						0.0 V														OE to Q 4	"	"	"			
145	"		"							0.0 V													OE to Q 5	"	"	"			
146	"		"								0.0 V												OE to Q 6	"	"	"			
147	"		"									0.0 V											OE to Q 7	"	"	"			

See footnotes at end of device type 03.

TABLE III. Group A inspection for device type 03.
Terminal conditions (pins not designated may be high ≥ 2.0 V; low ≤ 0.8 V; or open).

Subgroup	Symbol	MIL-STD-883 R.S.X.2 method	Cases Test no.	1	2	3	4	5	6	7	8	9	10	11	12	13	14	15	16	17	18	19	20	Measured terminal	Test limits		Unit	
				OE	D0	D1	D2	D3	D4	D5	D6	D7	GND	LE	\bar{Q} 7	\bar{Q} 6	\bar{Q} 5	\bar{Q} 4	\bar{Q} 3	\bar{Q} 2	\bar{Q} 1	\bar{Q} 0	V _{CC}		Min	Max		
9	t_{PZL1}	3003	148	IN	2.7 V								GND	2.7 V								OUT	5.0 V	OE to \bar{Q} 0	3.0	8.5	ns	
T _c = 25°C		Fig. 4	149	"		2.7 V							"	"							OUT	"	OE to \bar{Q} 1	"	"	"	"	
			150	"		2.7 V							"	"							OUT	"	OE to \bar{Q} 2	"	"	"	"	
			151	"		2.7 V							"	"					OUT			"	OE to \bar{Q} 3	"	"	"	"	
			152	"					2.7 V				"	"					OUT				"	OE to \bar{Q} 4	"	"	"	"
			153	"							2.7 V		"	"				OUT					"	OE to \bar{Q} 5	"	"	"	"
10	Same tests as subgroup 9, except T _c = +125°C and use limits from table I.		154	"							2.7 V		"	"	OUT								"	OE to \bar{Q} 6	"	"	"	"
11	Same tests as subgroup 10, except T _c = -55°C and use limits from table I.																											

1/ Perform function sequence at V_{CC} = 4.5 V and repeat at V_{CC} = 5.5 V.
 2/ I_{IL} limits (mA) min/max values for circuit shown:

Parameter	Circuit A	Circuit B	Circuit C
I _{IL}	-.25/-60	-.03/-60	-.03/-60

3/ A = 2.5 V, B = 0.5 V or GND, H ≥ 2.5 V, L ≤ 0.5 V.

TABLE III. Group A inspection for device type 04.
Terminal conditions (pins not designated may be high ≥ 2.0 V; low ≤ 0.8 V; or open).

Subgroup	Symbol	MIL-STD- method	Cases R.S.X.2 Test.no.	1	2	3	4	5	6	7	8	9	10	11	12	13	14	15	16	17	18	19	20	Measured terminal	Test limits		Unit					
																									Min	Max						
1	I_{IL}	3009	47	0.5 V									GND											5.5 V	OE	2/	2/	mA				
			48	0.5 V																						D0	"	"	"	"		
			49		0.5 V																						D1	"	"	"	"	
			50			0.5 V																					D2	"	"	"	"	
			51				0.5 V																				D3	"	"	"	"	
			52					0.5 V																			D4	"	"	"	"	
			53						0.5 V																		D5	"	"	"	"	
			54							0.5 V																	D6	"	"	"	"	
			55								0.5 V																D7	"	"	"	"	
			56									0.5 V															LE	"	"	"	"	"
			57	3011		0.0 V								5.5 V			0.5 V										O7	-60	-150		mA	
			58			"								5.5 V			5.5 V	0.0 V									O6	"	"	"	"	
			59			"							5.5 V				"	"									O5	"	"	"	"	
			60			"					5.5 V						"	"		0.0 V							O4	"	"	"	"	
			61			"						5.5 V					"	"				0.0 V						O3	"	"	"	"
			62			"											"	"					0.0 V					O2	"	"	"	"
			63			"								5.5 V			"	"										O1	"	"	"	"
			64			"	5.5 V										"	"										O0	"	"	"	"
			65			2.0 V								0.0 V			2.7 V											O7	"	"	50	μ A
			66			"								0.0 V			"	"										O6	"	"	"	"
			67			"							0.0 V				"	"										O5	"	"	"	"
			68			"					0.0 V						"	"										O4	"	"	"	"
69			"						0.0 V					"	"										O3	"	"	"	"			
70			"											"	"										O2	"	"	"	"			
71			"											"	"										O1	"	"	"	"			
72			"	0.0 V										"	"										O0	"	"	"	"			
73			"								5.5 V			"	"										O7	"	"	-50	"			
74			"								5.5 V			"	"										O6	"	"	"	"			
75			"							5.5 V				"	"										O5	"	"	"	"			
76			"						5.5 V					"	"										O4	"	"	"	"			
77			"											"	"										O3	"	"	"	"			
78			"											"	"										O2	"	"	"	"			
79			"								5.5 V			"	"										O1	"	"	"	"			
80			"	5.5 V										"	"										O0	"	"	"	"			
81	3005		0.0 V	0.0 V	0.0 V	0.0 V	0.0 V	0.0 V	0.0 V	0.0 V	0.0 V	0.0 V	0.0 V	"	"										V _{CC}	"	"	55	mA			
82	3005		5.5 V	0.0 V	0.0 V	0.0 V	0.0 V	0.0 V	0.0 V	0.0 V	0.0 V	0.0 V	0.0 V	"	"										"	"	"	55	mA			
2	Same tests, terminal conditions, and limits as subgroup 1, except $T_C = +125^\circ\text{C}$ and V_{IC} tests are omitted.																															
3	Same tests, terminal conditions, and limits as subgroup 1, except $T_C = -55^\circ\text{C}$ and V_{IC} tests are omitted.																															
7	Functional tests 3/	3014	83	B	B	A	B	A	B	A	B	A	GND	A	H	L	H	L	H	L	H	L	H	L	1/	All outputs	"	"				
			84	"	A	B	A	B	A	B	A	B	A	B	"	A	L	H	L	H	L	H	L	H	L	"	"	"	"			
			85	"	A	B	A	B	A	B	A	B	A	B	"	B	L	H	L	H	L	H	L	H	L	"	"	"	"			
			86	"	B	A	B	A	B	A	B	A	B	A	"	B	L	H	L	H	L	H	L	H	L	"	"	"	"			
			87	"	B	A	B	A	B	A	B	A	B	A	"	A	L	H	L	H	L	H	L	H	L	"	"	"	"			
			88	"	A	B	A	B	A	B	A	B	A	B	"	A	L	H	L	H	L	H	L	H	L	"	"	"	"			
			89	"	B	A	B	A	B	A	B	A	B	A	"	"	L	H	L	H	L	H	L	H	L	"	"	"	"			
			90	"	B	A	B	A	B	A	B	A	B	A	"	B	L	H	L	H	L	H	L	H	L	"	"	"	"			
			91	"	A	B	A	B	A	B	A	B	A	B	"	B	L	H	L	H	L	H	L	H	L	"	"	"	"			
			8	Same tests, terminal conditions, and limits as for subgroup 7, except $T_C = +125^\circ\text{C}$ and $T_C = -55^\circ\text{C}$.																												

See footnotes at end of device type 04.

TABLE III. Group A inspection for device type 04.
Terminal conditions (pins not designated may be high ≥ 2.0 V; low ≤ 0.8 V; or open).

Subgroup	Symbol	MIL-STD-883 R.S.X.2 Test no.	Cases	1	2	3	4	5	6	7	8	9	10	11	12	13	14	15	16	17	18	19	20	Test limits		Unit											
																								Measured terminal	Min		Max										
9	t_{PH1}	3003 Fig. 4	92	OE	IN	IN							GND	2.7 V										5.0 V	3.0	7.0	ns										
				93																																	
				94																																	
				95			IN															OUT															
				96																																	
				97																																	
				98																																	
				99												IN																					
				100				IN																													
				101					IN																												
				102						IN																											
				103							IN																										
				104								IN																									
				105									IN																								
				106										IN																							
				107											IN																						
				108												IN																					
				109													IN																				
				110																																	
111																																					
112																																					
113																																					
114																																					
115																																					
116																																					
117																																					
118																																					
119																																					
120																																					
121																																					
122																																					
123																																					
124																																					
125																																					
126																																					
127																																					
128																																					
129																																					
130																																					
131																																					
132																																					
133																																					
134																																					
135																																					
136																																					
137																																					
138																																					
139																																					

See footnotes at end of device type 04.

TABLE III. Group A inspection for device type 04.
Terminal conditions (pins not designated may be high ≥ 2.0 V; low ≤ 0.8 V; or open).

Subgroup	Symbol	MIL-STD-883 R.S.X.2 method	Cases Test no.	1	2	3	4	5	6	7	8	9	10	11	12	13	14	15	16	17	18	19	20	Measured terminal	Test limits		Unit		
				OE	D0	D1	D2	D3	D4	D5	D6	D7	GND	LE	Q7	Q6	Q5	Q4	Q3	Q2	Q1	Q0	V _{CC}		Min	Max			
9	T _c = 25°C	3003	140	IN	2.7 V																			OE to Q0	2.0	8.0	ns		
			141	"		2.7 V																			OE to Q1	"	"	"	
			142	"			2.7 V																			OE to Q2	"	"	"
			143	"						2.7 V																OE to Q3	"	"	"
			144	"							2.7 V															OE to Q4	"	"	"
			145	"								2.7 V														OE to Q5	"	"	"
			146	"									2.7 V													OE to Q6	"	"	"
			147	"											2.7 V											OE to Q7	"	"	"
			148	t _{pZL1}	"						0.0 V															OE to Q0	"	8.5	"
			149	"	"							0.0 V														OE to Q1	"	"	"
			150	"	"								0.0 V													OE to Q2	"	"	"
			151	"	"									0.0 V												OE to Q3	"	"	"
			152	"	"										0.0 V											OE to Q4	"	"	"
			153	"	"											0.0 V										OE to Q5	"	"	"
			154	"	"												0.0 V									OE to Q6	"	"	"
155	"	"													0.0 V								OE to Q7	"	"	"			
10	Same tests as subgroup 9, except T _c = +125°C and use limits from table I.																												
11	Same tests as subgroup 10, except T _c = -55°C and use limits from table I.																												

1/ Perform function sequence at V_{CC} = 4.5 V and repeat at V_{CC} = 5.5 V.

2/ I_{IL} limits (mA) min/max values for circuit shown:

Parameter	Circuits		
	A	B	C
I _{IL}	-0.25/- .60	-0.03/- .60	-0.03/- .60

3/ A ≥ 2.5 V, B ≤ 0.5 V or GND, H ≥ 1.5 V, L ≤ 1.5 V.

5. PACKAGING

5.1 Packaging requirements. For acquisition purposes, the packaging requirements shall be as specified in the contract or order (see 6.2). When actual packaging of materiel is to be performed by DoD or in-house contractor personnel, these personnel need to contact the responsible packaging activity to ascertain packaging requirements. Packaging requirements are maintained by the Inventory Control Point's packaging activity within the Military Service or Defense Agency, or within the military service's system command. Packaging data retrieval is available from the managing Military Department's or Defense Agency's automated packaging files, CD-ROM products, or by contacting the responsible packaging activity.

6. NOTES

6.1 Intended use. Microcircuits conforming to this specification are intended for original equipment design applications and logistic support of existing equipment.

6.2 Acquisition requirements. Acquisition documents should specify the following:

- a. Title, number, and date of the specification.
- b. PIN and compliance identifier, if applicable (see 1.2).
- c. Requirements for delivery of one copy of the conformance inspection data pertinent to the device inspection lot to be supplied with each shipment by the device manufacturer, if applicable.
- d. Requirements for certificate of compliance, if applicable.
- e. Requirements for notification of change of product or process to contracting activity in addition to notification to the qualifying activity, if applicable.
- f. Requirements for failure analysis (including required test condition of method 5003 of MIL-STD-883), corrective action, and reporting of results, if applicable.
- g. Requirements for product assurance options.
- h. Requirements for special carriers, lead lengths, or lead forming, if applicable. These requirements should not affect the part number. Unless otherwise specified, these requirements will not apply to direct purchase by or direct shipment to the Government.
- i. Requirements for "JAN" marking.
- j. Packaging requirements (see 5.1).

6.3 Superseding information. The requirements of MIL-M-38510 have been superseded to take advantage of the available Qualified Manufacturer Listing (QML) system provided by MIL-PRF-38535. Previous references to MIL-M-38510 in this document have been replaced by appropriate references to MIL-PRF-38535. All technical requirements now consist of this specification and MIL-PRF-38535. The MIL-M-38510 specification sheet number and PIN have been retained to avoid adversely impacting existing government logistics systems and contractor's parts lists.

6.4 Qualification. With respect to products requiring qualification, awards will be made only for products which are, at the time of award of contract, qualified for inclusion in Qualified Manufacturers List QML-38535 whether or not such products have actually been so listed by that date. The attention of the contractors is called to these requirements, and manufacturers are urged to arrange to have the products that they propose to offer to the Federal Government tested for qualification in order that they may be eligible to be awarded contracts or purchase orders for the products covered by this specification. Information pertaining to qualification of products may be obtained from DSCC-VQ, 3990 E. Broad Street, Columbus, Ohio 43123-1199.

6.5 Abbreviations, symbols, and definitions. The abbreviations, symbols, and definitions used herein are defined in MIL-PRF-38535, MIL-HDBK-1331, and as follows:

GND Ground zero voltage potential
 I_{IN} Current flowing into an input terminal
 V_{IN} Voltage level at an input terminal

6.6 Logistic support. Lead materials and finishes (see 3.4) are interchangeable. Unless otherwise specified, microcircuits acquired for Government logistic support will be acquired to device class B (see 1.2.2), lead material and finish A (see 3.4). Longer length leads and lead forming should not affect the part number.

6.7 Substitutability. The cross-reference information below is presented for the convenience of users. Microcircuits covered by this specification will functionally replace the listed generic-industry type. Generic-industry microcircuit types may not have equivalent operational performance characteristics across military temperature ranges or reliability factors equivalent to MIL-M-35810 device types and may have slight physical variations in relation to case size. The presence of this information should not be deemed as permitting substitution of generic-industry types for MIL-M-38510 types or as a waiver of any of the provisions of MIL-PRF-38535.

Military device type	Generic-industry type
01	54F373
02	54F533
03	54F563
04	54F573

6.8 Manufacturers' designation. Manufacturers' circuits which form a part of this specification are designated with an "X" as shown in table IV herein.

TABLE IV. Manufacturers' designations.

Device type	Circuit			
	A	B	C	D
	National Semiconductor/ Fairchild Semiconductor	Motorola Inc.	Signetics Corp.	Texas Instruments
01	X	X	X	X
02	X	X		
03	X			
04	X			

6.9 Changes from previous issue. Marginal notations are not used in this revision to identify changes with respect to the previous issue due to the extensiveness of the changes.

Custodians:
Army - CR
Navy - EC
Air Force - 11
DLA - CC

Preparing activity:
DLA - CC

(Project 5962-2034)

Review activities:
Army - MI, SM
Navy - AS, CG, MC, SH, TD
Air Force - 03, 19, 99

NOTE: The activities listed above were interested in this document as of the date of this document. Since organizations and responsibilities can change, you should verify the currency of the information above using the ASSIST Online database at www.dodssp.daps.mil.