

FEATURES

- Enables Power Supply Tracking of multiple supplies
- Capacitor Adjustable Linear Slew Rate
- On Board Charge Pump Fully enhances NFET
- Up/Down slew rate control to approx. +/-100mV
- Ability to Track Down Supplies (ADM1200-1)
- Emergency Shutdown Feature (ADM1200-2)
- Packaged in tiny 6-Lead SOT-23 Package

APPLICATIONS

- Multi-Voltage Supply Rail Tracker
- Telecoms and Datacoms Systems
- Multi voltage Network Processors , FPGAs, ASICs, DSPs
- PC/Server Applications

GENERAL DESCRIPTION

The ADM1200 is FET driver capable of driving N channel FETs. It features a capacitor programmable SLEW rate control system ensuring that the output voltage rises and falls at a controlled rate and in a linear fashion. The ADM1200 is designed to ensure that the output voltage follows the voltage on the SLEW pin to within ~100mV. It can also be cascaded to perform simple tracking functionality of supply rails ensuring that each voltage rail tracks within ~100mV of each other in multi supply systems. Any number of these devices can be cascaded to form a multi supply tracking solution.

The ADM1200 requires 2.7V to 16.5V on its Vcc pin to operate. An on-board charge pump generates a high voltage GATE drive to fully enhance FETs in the power path.

The Slew Rate of the ramp is adjustable via an external capacitor on the CSLEW pin and can be programmed from 100V/s to 1000V/s. When multiple devices are cascaded the CSLEW pin of each subsequent device should be tied to the output rail (VOUTFB) of the previous device to ensure that supply will slew up and down with the previous supply.

The ADM1200 is offered in two variants. The ADM1200-1 features an UP/DOWN pin and the ADM1200-2 features an Up/STOP pin. For both devices a high level on the this input will initiate tracking up sequence. A low on the UP/DOWN pin of the ADM1200-1 will initiate a tracking down of the supply rails, while a low on the UP/STOP pin of the ADM1200-2 will initiate an emergency fast shutdown of all supply rails simultaneously. The ADM1200 is packaged in a tiny 6-pin SOT-23 package.

Rev. PrJ

Information furnished by Analog Devices is believed to be accurate and reliable. However, no responsibility is assumed by Analog Devices for its use, nor for any infringements of patents or other rights of third parties that may result from its use. Specifications subject to change without notice. No license is granted by implication or otherwise under any patent or patent rights of Analog Devices. Trademarks and registered trademarks are the property of their respective companies.

Functional Block Diagram

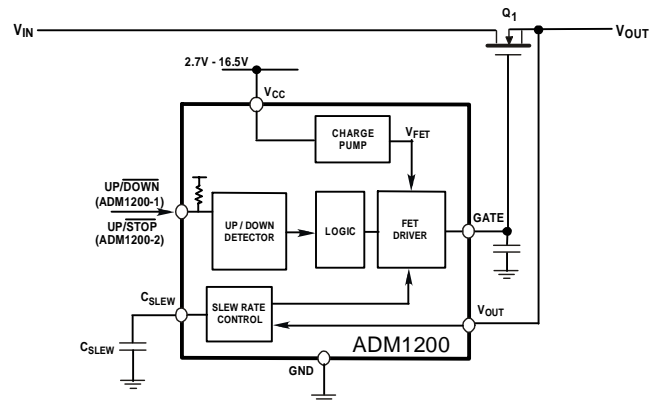

Applications Diagram

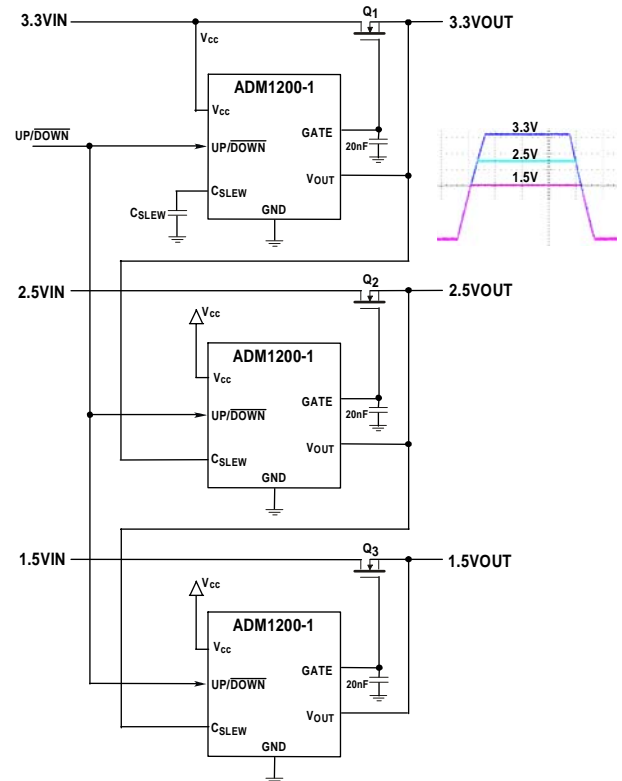

ADM1200—SPECIFICATIONS

Table 1. V_{CC} = Full Operating Range, T_A = -40°C to +105°C, unless otherwise noted.

Parameter	Min	Typ	Max	Units	Conditions
V_{CC} Pin					
Operating Voltage Range V _{CC}	2.7		16.5	V	V _{CC} Rising
Undervoltage Lockout, V _{UVLO}	2.4	2.525	2.65	V	
UVLO Hysteresis		25		mV	
Switched Voltage Range	0.65		16.5	V	
Quiescent Current		0.5	1.5	mA	
Up/Downb Pin					
Input Threshold	0.6	0.63	0.66	V	Rising
Input Threshold Hysteresis		60		mV	
Input Current	-100		100	nA	
C_{SLEW} Pin					
Slew up Current		-10		μA	V _{SLEW} /V _{OUTFB}
Slew down Current		10		μA	
Slew Gain		1		V/V	
Minimum Tracking Voltage		0.1		V	
Maximum Tracking voltage		V _{CC} - 0.3		V	
Tracking Delta		100		mV	V _{OUTFB} - V _{SLEW}
Slew Rate	100		1000	V/s	
V_{OUTFB} Pin					
Input Current	-12		12	μA	Must not exceed V _{CC}
Voltage Range	0		V _{CC}	V	
GATE Pin					
Gate Pullup Current		10		μA	V _{slew} - V _{out} > 100mV
Gate Pulldown Current		12		μA	V _{out} - V _{slew} > 100mV
Gate Pulldown Current		2		mA	ADM1200-2 only; vgate = 3.0V
GATE Voltage, V _{GATE}	4	5.5	8	V	V _{GATE} - V _{CC} ; V _{CC} = 2.7V
	6	8	10	V	V _{GATE} - V _{CC} ; V _{CC} = 3.3V
	8	10	12	V	V _{GATE} - V _{CC} ; V _{CC} = 5.0V
	6	8	12	V	V _{GATE} - V _{CC} ; V _{CC} = 16.5V

Absolute Maximum Ratings

Table 2. ADM1200 Absolute Maximum Ratings

Parameter	Rating
V _{CC} Pin	-0.3V to 20V
UP/DOWNb, UP/STOPb	-0.3V to 20V
C _{SLEW} Pin	-0.3V to 20V
Gate Pin	-0.3V to (V _{CC} + 11V)
V _{OUTFB} Pin	-0.3V to (V _{CC} + 0.3V)
Power Dissipation	TBD
Storage Temperature	-65°C to +125°C
Operating Temperature Range	-40°C to +105°C
Lead Temperature Range (Soldering 10 sec)	300°C
Junction Temperature	150°C

GENERAL INFORMATION

The ADM1200 provides a solution for slew rate control, linear supply regulation and voltage tracking. The device requires a supply voltage of 2.7V to 16.5V on its Vcc pin for operation. The device may be powered from the input supply rail that is being switched or from an auxiliary supply providing it does not exceed the voltage to be expected on the devices V_{OUTFB} pin.

GATE

An internal charge pump ensures that the ADM1200 is capable of fully enhancing an external N channel FET via the GATE pin. An external capacitor may be required on the GATE node for stability. During under voltage lockout the GATE pin is held low to avoid any glitches on the FETs gate and prevent false power ups.

SLEW

The value of the slew rate capacitor, C_{SLEW}, will dictate the slew rate of the output voltage. An internal current source charges C_{SLEW} in a linear fashion and the GATE voltage is controlled so that V_{OUT} will be regulated to within 100mV from V_{SLEW}. The maximum voltage that the ADM1200 can control is 0.3V below Vcc. Once the SLEW pin reaches this maximum voltage the GATE is driven fully high.

The C_{SLEW} capacitor is determined by:

$$C_{SLEW} = 10\mu A / \text{Slewrates}(V/s)$$

On the ADM1200-2 only, a high to low on the UP/DOWN pin will enable a current sink on the SLEW pin to discharge the capacitor at the same rate. This will initiate a SLEW down of the output.

VOUTFB

The V_{OUTFB} pin monitors the output voltage to ensure it is kept within approximately 100mV of the voltage on the SLEW pin. This pin must not exceed the Vcc voltage at any time or it may cause damage to the device.

UP/DOWN AND UP/STOP

Power up can be externally initiated by driving the UP/DOWNb (ADM1200-1) or UP/STOPb (ADM1200-2) logic pin high. A low on the ADM1200-1 will initiate a track down and on the ADM1200-2 the gate will shutdown immediately. This is illustrated in Figure 1 and Figure 2.

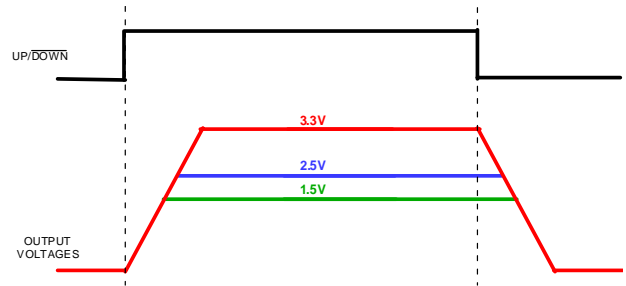

Figure 1. ADM1200-1 Power-Up and Power-Down Waveforms

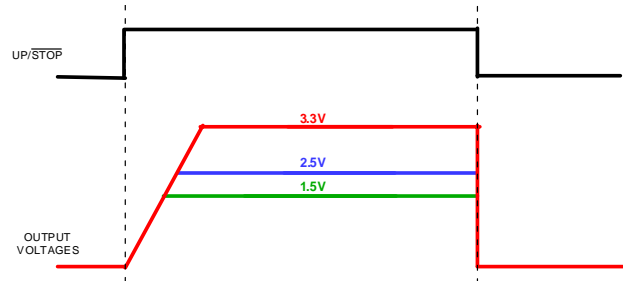

Figure 2. ADM1200-2 Power-Up and Power-Down Waveforms

ENABLING A SINGLE SUPPLY

A single ADM1200 device may be used where a single supply rail is required to switch on at a controlled linear slew rate (see Figure 3). The capacitor C_{SLEW} determines the slew rate

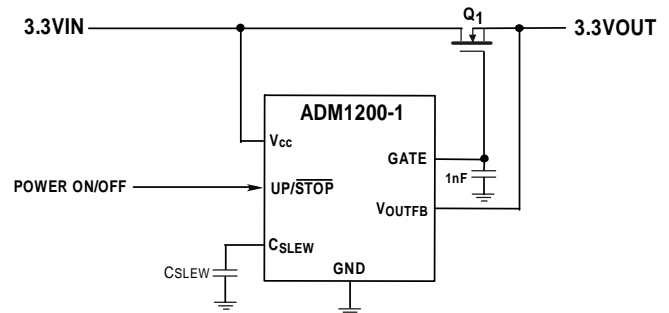

Figure 3. ADM1200 Switching on a Single Supply

MULTI-SUPPLY TRACKING

The ADM1200 can be used to provide a voltage tracking solution for multiple supply rails. The implementation in Figure 4 will provide this function. Each voltage rail has its own ADM1200 device driving a FET.

The UP/DOWNb (ADM1200-1) or UP/STOPb (ADM1200-2) pins of all devices can be driven by a single logic input which will initiate a system power-up going high or power-down going low.

In Figure 4, the ADM1200 is configured to control the ramp of the largest supply first. The output of the first device is

connected to the slew pin on the second device to allow the rate of the first supply to control the rate of the second and so on.

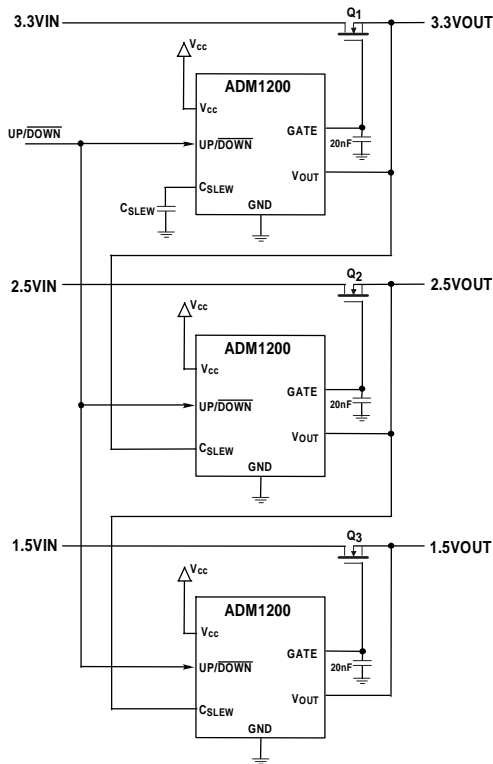

Figure 4. . ADM1200 Solution for Tracking 3 Supplies

A low-to-high transition on the UP/DOWNb or UP/STOPb pin will initiate turn-on of the supplies. The first ADM1200 device will begin to source current into the C_{SLEW} capacitor. This will bring up the Gate in an attempt to ensure the output voltage will follow the SLEW voltage. The output voltage is monitored using V_{OUTFB} pin. The output will then track the SLEW voltage on this device. Figure 5 shows an actual plot of two supplies tracking up. The output of this first supply is then fed into the SLEW pin of the next ADM1200. This will override the slew current on this device. The second ADM1200 will then ensure that the output of the second supply will track up/down along with the output from the first. Any number of ADM1200 devices can be cascaded in this way. Figure 5 and Figure 6 show actual waveforms of the output voltages for ADM1200-1 and ADM1200-2 devices in this configuration.

A high-to-low on the UP/DOWNb pin of the ADM1200-1 will initiate a tracking down of the supply rails. The voltages will attempt to stay with ~100mV of each other assuming the load current will be sufficient to discharge the capacitors at the required rate. During a high to low on the UP/STOPb pin, the ADM1200-2 device will pull the GATE to the FET low immediately but the output voltage will only fall at a rate determined by the load capacitance and impedance.

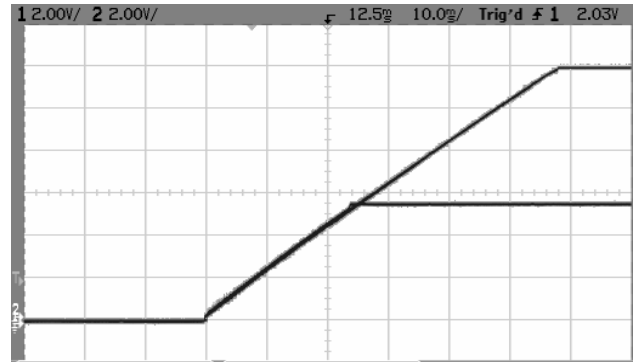

Figure 5. Tracking up Waveforms

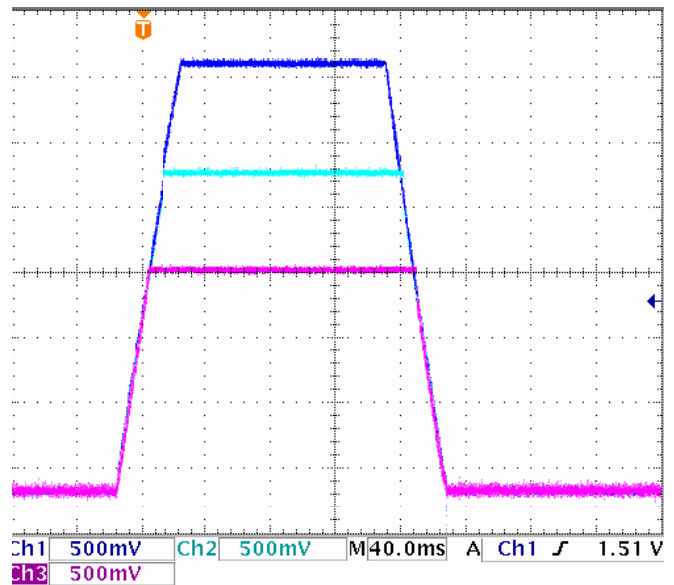

Figure 6 ADM1200-1 Track up and Track down.

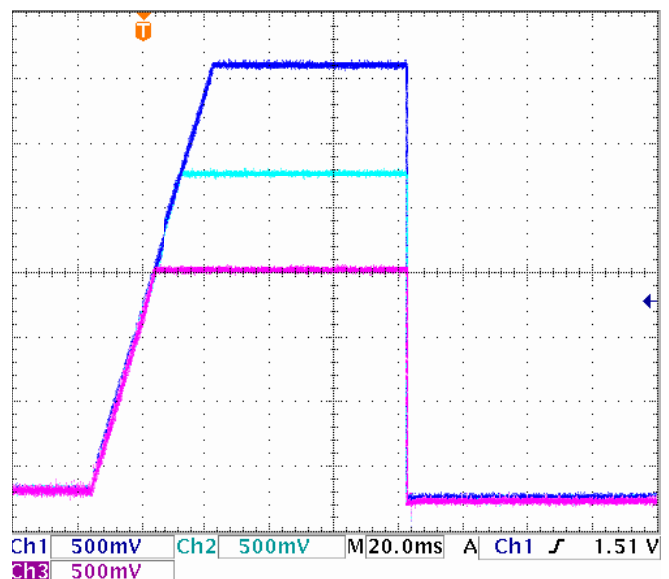
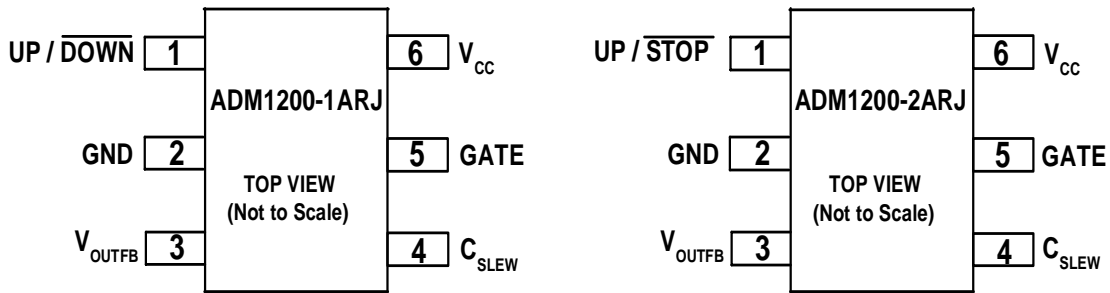

Figure 7. ADM1200-2 Track up and stop.

PIN CONFIGURATIONS



PIN FUNCTIONAL DESCRIPTIONS

Pin No.	Name	Description
1	UP/DOWNb or UP/STOPb	Logic Pin. Drive high to initiate slew up. Drive low to initiate slew down of output (ADM1200-1) or a fast shutdown of output (ADM1200-2).
2	GND	Chip Ground Pin.
3	VOUTFB	Monitors the output voltage at the source of the external FET. Must not exceed V _{CC} .
4	CSLEW	Connect to an external capacitor to control the slew rate of the output for power up (and power down for ADM1200-1).
5	GATE	Drives the GATE node of the external FET
6	VCC	Chip Power Supply, 2.7V to 16.5V. Recommended decoupling cap of 100nF

OUTLINE DIMENSIONS

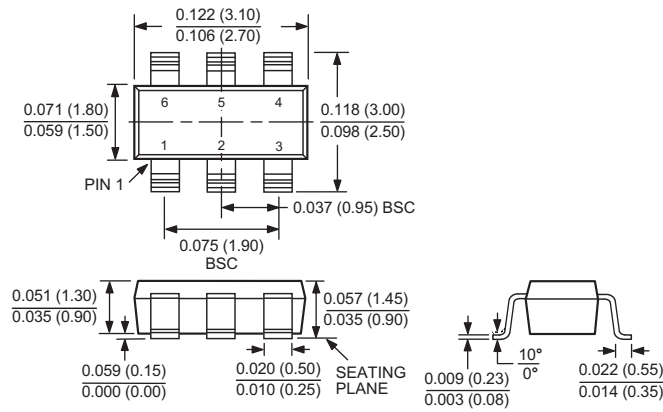

Figure 5. 6-Lead SOT-23 Package (RJ-6)—Dimensions shown in millimeters

ESD CAUTION

ESD (electrostatic discharge) sensitive device. Electrostatic charges as high as 4000 V readily accumulate on the human body and test equipment and can discharge without detection. Although this product features proprietary ESD protection circuitry, permanent damage may occur on devices subjected to high energy electrostatic discharges. Therefore, proper ESD precautions are recommended to avoid performance degradation or loss of functionality.



Table 3. Ordering Guide

Model	Temperature Range	Package Description	Package Option	Branding
ADM1200-1WRJZ-RL7	-40°C to +105°C	8-Lead TSOT	RJ-6	M1S
ADM1200-2WRJZ-RL7	-40°C to +105°C	8-Lead TSOT	RJ-6	M1U