



3.3V CMOS SINGLE 2-INPUT POSITIVE-NAND GATE

IDT74ALVC1G00 ADVANCE INFORMATION

FEATURES:

- 0.5 MICRON CMOS Technology
- ESD > 2000V per MIL-STD-883, Method 3015; > 200V using machine model (C = 200pF, R = 0)
- 0.65mm pitch PSOP package
- Extended commercial range of - 40°C to + 85°C
- Vcc = 3.3V ± 0.3V, Normal Range
- Vcc = 1.65V to 3.6V, Extended Range
- Vcc = 2.5V ± 0.2V
- CMOS power levels (0.4µW typ. static)
- Rail-to-Rail output swing for increased noise margin

Drive Features for ALVC1G00:

- High Output Drivers: ±24mA
- Suitable for heavy loads

DESCRIPTION:

This single 2-input positive-NAND gate is built using advanced dual metal CMOS technology. The ALVC1G00 is designed for 1.65V to 3.6V Vcc operation and performs the Boolean function $Y = A \cdot B$ or $Y = \overline{A + B}$ in positive logic.

The ALVC1G00 has been designed with a ±24mA output driver. This driver is capable of driving a moderate to heavy load while maintaining speed performance.

APPLICATIONS:

- 3.3V High Speed Systems
- 3.3V and lower voltage computing systems

FUNCTIONAL BLOCK DIAGRAM

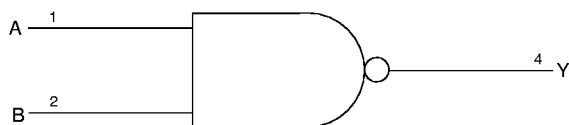

PIN CONFIGURATION

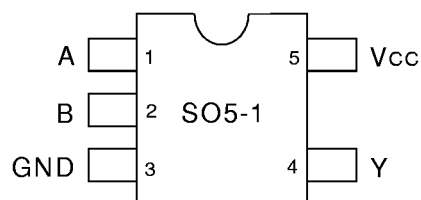

PSOP
TOP VIEW

PIN DESCRIPTION

Pin Names	Description
A, B	Data Inputs
Y	Data Output

FUNCTION TABLE (1)

Inputs		Output
A	B	Y
H	H	L
L	X	H
X	L	H

NOTE:

1. H = HIGH Voltage Level
L = LOW Voltage Level
X = Don't Care

ABSOLUTE MAXIMUM RATING (1)

Symbol	Description	Max.	Unit
V _{TERM} (2)	Terminal Voltage with Respect to GND	- 0.5 to + 4.6	V
V _{TERM} (3)	Terminal Voltage with Respect to GND	-0.5 to V _{CC} + 0.5	V
T _{STG}	Storage Temperature	- 65 to + 150	°C
I _{OUT}	DC Output Current	- 50 to + 50	mA
I _{IK}	Continuous Clamp Current, V _I < 0 or V _I > V _{CC}	± 50	mA
I _{OK}	Continuous Clamp Current, V _O < 0	- 50	mA
I _{CC}	Continuous Current through each V _{CC} or GND	±100	mA

ALVC 1G Link

NOTES:

1. Stresses greater than those listed under ABSOLUTE MAXIMUM RATINGS may cause permanent damage to the device. This is a stress rating only and functional operation of the device at these or any other conditions above those indicated in the operational sections of this specification is not implied. Exposure to absolute maximum rating conditions for extended periods may affect reliability.
2. V_{CC} terminals.
3. All terminals except V_{CC}.

CAPACITANCE (TA = +25°C, f = 1.0MHz)

Symbol	Parameter(1)	Conditions	Typ.	Max.	Unit
C _{IN}	Input Capacitance	V _{IN} = 0V	5	7	pF
C _{OUT}	Output Capacitance	V _{OUT} = 0V	7	9	pF
C _{I/O}	I/O Port Capacitance	V _{IN} = 0V	7	9	pF

ALVC 1G Link

NOTE:

1. As applicable to the device type.

DC ELECTRICAL CHARACTERISTICS OVER OPERATING RANGE

Following Conditions Apply Unless Otherwise Specified:

Operating Condition: TA = - 40°C to +85°C, V_{CC} = 2.3V to 3.6V

Symbol	Parameter	Test Conditions		Min.	Typ.(1)	Max.	Unit
V _{IH}	Input HIGH Voltage Level	V _{CC} = 1.65V to 1.95V		0.65 x V _{CC}	—	—	V
		V _{CC} = 2.3V to 2.7V		1.7	—	—	
		V _{CC} = 2.7V to 3.6V		2	—	—	
V _{IL}	Input LOW Voltage Level	V _{CC} = 1.65V to 1.95V		—	—	0.35 x V _{CC}	V
		V _{CC} = 2.3V to 2.7V		—	—	0.7	
		V _{CC} = 2.7V to 3.6V		—	—	0.8	
I _{IH}	Input HIGH Current	V _{CC} = 3.6V	V _I = V _{CC}	—	—	± 5	μA
I _{IL}	Input LOW Current	V _{CC} = 3.6V	V _I = GND	—	—	± 5	μA
I _{OZH}	High Impedance Output Current (3-State Output pins)	V _{CC} = 3.6V	V _O = V _{CC}	—	—	± 10	μA
I _{OZL}			V _O = GND	—	—	± 10	μA
V _{IK}	Clamp Diode Voltage	V _{CC} = 2.3V, I _{IN} = - 18mA		—	- 0.7	- 1.2	V
V _H	Input Hysteresis	V _{CC} = 3.3V		—	100	—	mV
I _{OCL}	Quiescent Power Supply Current	V _{CC} = 3.6V		—	0.1	10	μA
I _{OCH}		V _{IN} = GND or V _{CC}					
I _{OZZ}							
ΔI _{CC}	Quiescent Power Supply Current Variation	One input at V _{CC} - 0.6V, other inputs at V _{CC} or GND		—	—	750	μA

ALVC 1G Link

NOTE:

1. Typical values are at V_{CC} = 3.3V, +25°C ambient.

OUTPUT DRIVE CHARACTERISTICS

Symbol	Parameter	Test Conditions ⁽¹⁾		Min.	Max.	Unit
VOH	Output HIGH Voltage	V _{CC} = 1.65V to 3.6V	I _{OH} = -0.1mA	V _{CC} - 0.2	—	V
		V _{CC} = 1.65V	I _{OH} = -4mA	1.2		
		V _{CC} = 2.3V	I _{OH} = -6mA	2	—	
		V _{CC} = 2.3V	I _{OH} = -12mA	1.7	—	
		V _{CC} = 2.7V		2.2	—	
		V _{CC} = 3.0V		2.4	—	
		V _{CC} = 3.0V	I _{OH} = -24mA	2	—	
VOL	Output LOW Voltage	V _{CC} = 1.65V to 3.6V	I _{OL} = 0.1mA	—	0.2	V
		V _{CC} = 1.65V	I _{OL} = 4mA		0.45	
		V _{CC} = 2.3V	I _{OL} = 6mA	—	0.4	
			I _{OL} = 12mA	—	0.7	
		V _{CC} = 2.7V	I _{OL} = 12mA	—	0.4	
		V _{CC} = 3.0V	I _{OL} = 24mA	—	0.55	

ALVC 1G Link

NOTE:

1. V_{IH} and V_{IL} must be within the min. or max. range shown in the DC ELECTRICAL CHARACTERISTICS OVER OPERATING RANGE table for the appropriate V_{CC} range. T_A = -40°C to +85°C.

OPERATING CHARACTERISTICS, T_A = 25°C

Symbol	Parameter	Test Conditions	V _{CC} = 1.8V ± 0.15V	V _{CC} = 2.5V ± 0.2V	V _{CC} = 3.3V ± 0.3V	Unit
			Typical	Typical	Typical	
CPD	Power Dissipation Capacitance	C _L = 0pF, f = 10Mhz		5	6	pF

SWITCHING CHARACTERISTICS⁽¹⁾

Symbol	Parameter	V _{CC} = 1.8V ± 0.15V		V _{CC} = 2.5V ± 0.2V		V _{CC} = 2.7V		V _{CC} = 3.3V ± 0.3V		Unit
		Min.	Max.	Min.	Max.	Min.	Max.	Min.	Max.	
t _{PLH}	Propagation Delay A or B to Y	1	8	1	3.8		3.6	1	3.2	ns
t _{PHL}										

NOTE:

1. See test circuits and waveforms. T_A = -40°C to +85°C.

TEST CIRCUITS AND WAVEFORMS:

TEST CONDITIONS

Symbol	V _{cc} (1) = 3.3V ± 0.3V	V _{cc} (1) = 2.7V	V _{cc} (2) = 2.5V ± 0.2V	Unit
V _{LOAD}	6	6	2 x V _{cc}	V
V _{IH}	2.7	2.7	V _{cc}	V
V _T	1.5	1.5	V _{cc} / 2	V
V _{LZ}	300	300	150	mV
V _{HZ}	300	300	150	mV
C _L	50	50	30	pF

ALVC 1G Link

TEST CIRCUITS FOR ALL OUTPUTS

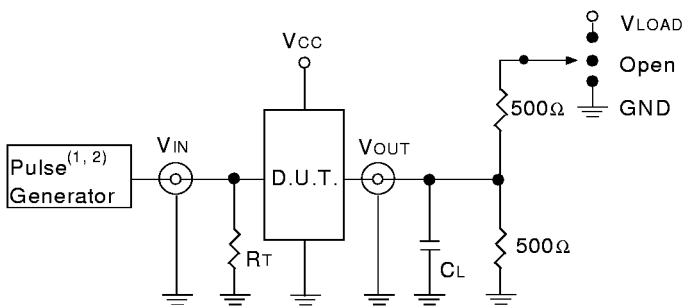

ALVC 1G Link

DEFINITIONS:

C_L = Load capacitance: includes jig and probe capacitance.
 R_T = Termination resistance: should be equal to Z_{OUT} of the Pulse Generator.

NOTES:

1. Pulse Generator for All Pulses: Rate ≤ 10MHz; t_F ≤ 2.5ns; t_R ≤ 2.5ns.
2. Pulse Generator for All Pulses: Rate ≤ 10MHz; t_F ≤ 2ns; t_R ≤ 2ns.

SWITCH POSITION

Test	Switch
Open Drain Disable Low Enable Low	V _{LOAD}
Disable High Enable High	GND
All Other tests	Open

ALVC 1G Link

PULSE WIDTH

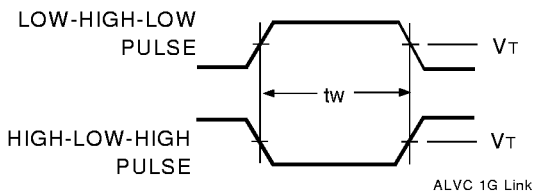

ALVC 1G Link

PROPAGATION DELAY

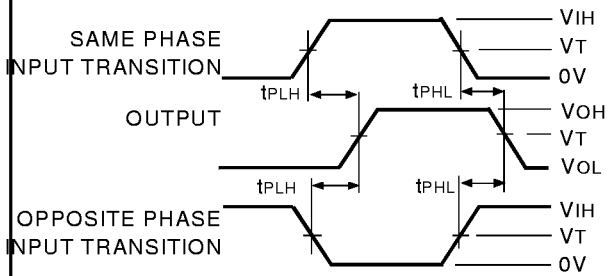

ALVC 1G Link

ENABLE AND DISABLE TIMES

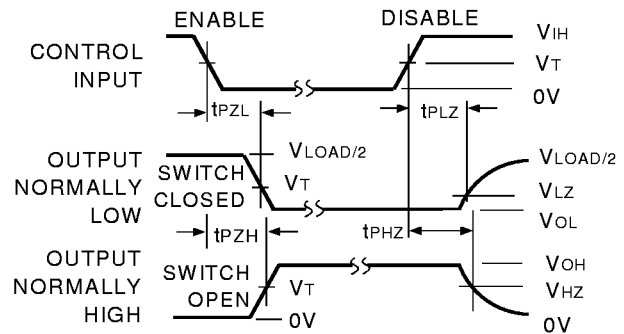

ALVC 1G Link

NOTE:

1. Diagram shown for input Control Enable-LOW and input Control Disable-HIGH.

SET-UP, HOLD, AND RELEASE TIMES

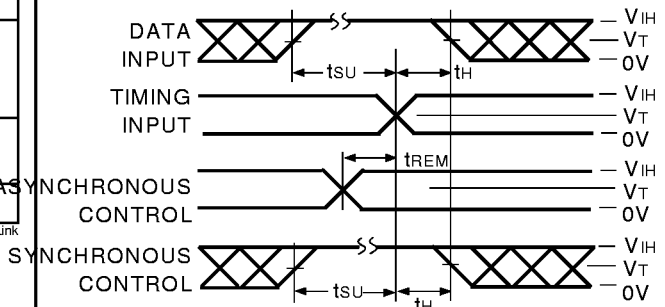

ALVC 1G Link

1.8V ± 0.15V TEST CIRCUITS AND WAVEFORMS:

TEST CONDITIONS

Symbol	V _{cc} (1) = 1.8V ± 0.15V	Unit
V _{LOAD}	2 x V _{cc}	V
V _{IH}	V _{cc}	V
V _T	V _{cc} / 2	V
V _{LZ}	150	mV
V _{HZ}	150	mV
C _L	30	pF

ALVC 1G Link

PROPAGATION DELAY

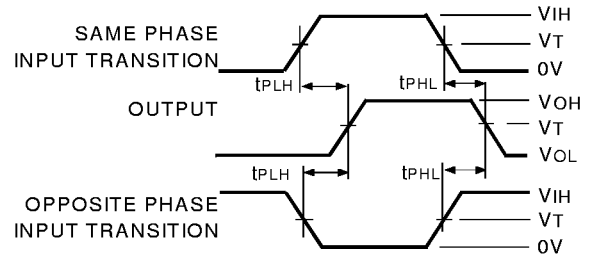

ALVC 1G Link

TEST CIRCUITS FOR ALL OUTPUTS

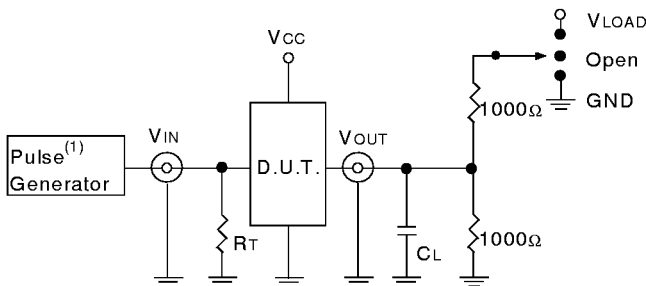

DEFINITIONS:

C_L = Load capacitance: includes jig and probe capacitance.
 R_T = Termination resistance: should be equal to Z_{OUT} of the Pulse Generator.

NOTE:

1. Pulse Generator for All Pulses: Rate ≤ 10MHz; t_f ≤ 2ns; t_r ≤ 2ns.

ENABLE AND DISABLE TIMES

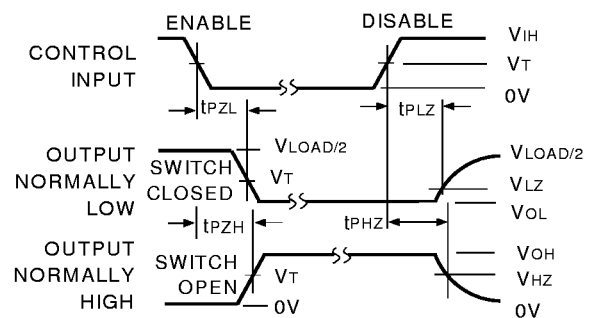

ALVC 1G Link

NOTE:

1. Diagram shown for input Control Enable-LOW and input Control Disable-HIGH.

SWITCH POSITION

Test	Switch
Open Drain Disable Low Enable Low	V _{LOAD}
Disable High Enable High	GND
All Other tests	Open

ALVC 1G Link

PULSE WIDTH

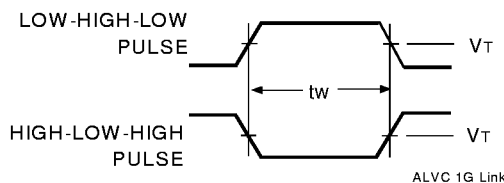

ALVC 1G Link

SET-UP, HOLD, AND RELEASE TIMES

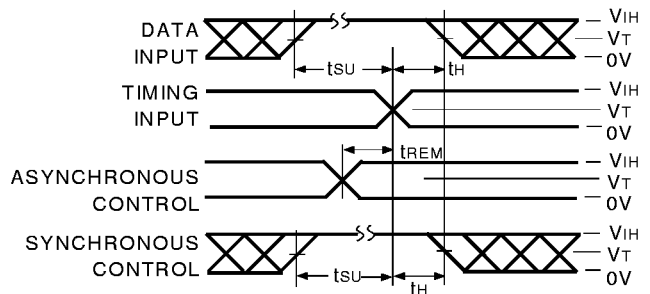

ALVC 1G Link

ORDERING INFORMATION

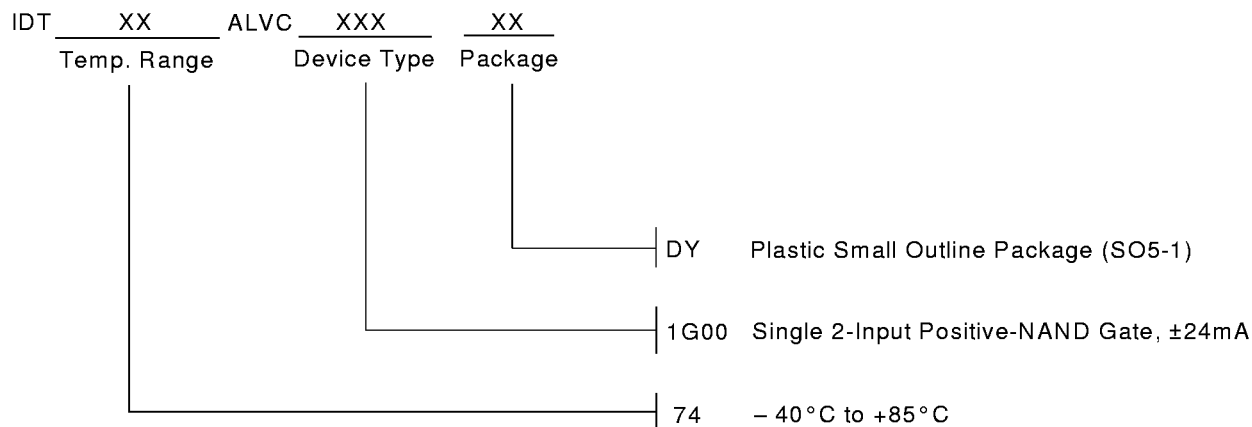

PICOLOGIC (DY) PACKAGES

Due to their small size, PicoGate-Logic packages require more complex symbolization guidelines. IDT's 5-pin PSOP (DY) packaged devices utilize a three-symbol name rule. The first symbol denotes device technology, the second symbol denotes device function, and the third symbol denotes a wafer fab/assembly site code for internal tracking.

EXAMPLES:

1. A PicoGate-Logic device with package code LR* is an IDT74LVC1G79A.
2. A PicoGate-Logic device with package code GC* is an IDT74ALVC1G04.

PICOLOGIC (DY) PACKAGE SYMBOLIZATION GUIDELINES

TECHNOLOGY	CODE	FUNCTION	CODE
ALVC	G	00	A
ALVCH	J	02	B
LVC	L	04	C
LVCH ⁽¹⁾		U04	D
		06	T
		07	V
		08	E
		14	F
		32	G
		79	R
		86	H
		125	M
		126	N
		132	Y

NOTE:

1. Code to be determined.



CORPORATE HEADQUARTERS
 2975 Stender Way
 Santa Clara, CA 95054

for SALES:
 800-345-7015 or 408-727-6116
 fax: 408-492-8674
 www.idt.com*

*To search for sales office near you, please click the sales button found on our home page or dial the 800# above and press 2.
 The IDT logo is a registered trademark of Integrated Device Technology, Inc.