

XC74UL32AA



CMOS Logic

- ◆ CMOS 2-Input OR Gate
- ◆ High Speed Operation : tpd = 3.8ns (TYP.)
- ◆ Operating Voltage Range : 2V ~ 5.5V
- ◆ Low Power Consumption : 1 μ A (MAX.)

APPLICATIONS

- Palmtops
- Digital equipment

GENERAL DESCRIPTION

The XC74UL32AA is a 2-input CMOS OR Gate, manufactured using silicon gate CMOS fabrication.

CMOS low power circuit operation makes high speed LS-TTL operation achievable.

With a wave forming buffer connected internally, stabilized output can be achieved as the circuit offers high noise immunity.

As the XC74UL32AA is integrated into mini molded, SSOT-25 and SOT-25 packages, high density mounting is possible.

FEATURES

- High Speed Operation** : tpd = 3.8ns (TYP.)
- Operating Voltage Range** : 2V ~ 5.5V
- Low Power Consumption**: 1 μ A (MAX.)
- Ultra Small Packages** : SSOT-25 and SOT-25

PIN CONFIGURATION

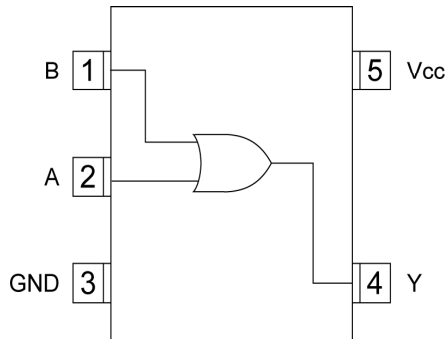

SSOT-25/SOT-25
(TOP VIEW)

FUNCTIONS

INPUT		OUTPUT
A	B	Y
L	L	L
L	H	H
H	L	H
H	H	H

H=High level
L=Low level

ABSOLUTE MAXIMUM RATINGS

Ta=-40°C~85°C

PARAMETER	SYMBOL	RATINGS	UNITS
Supply Voltage	VCC	-0.5~+6.0	V
Input Voltage	VIN	-0.5~+6.0	V
Output Voltage	VOUT	-0.5~VCC+0.5	V
Input Diode Current	I _{IK}	-20	mA
Output Diode Current	I _{OK}	±20	mA
Output Current	I _{OUT}	±25	mA
VCC,GND Current	I _{CC} ,I _{GND}	±50	mA
Power Dissipation(Ta=55°C)	P _d	150	mW
Storage Temperature Range	T _{stg}	-65~+150	°C

* Voltage is all ground standardized.

XC74UL32AA

RECOMMENDED OPERATING CONDITIONS

PARAMETER	SYMBOL	V _{CC} (V)	CONDITIONS	UNITS
Supply Voltage	V _{CC}	—	2~5.5	V
Input Voltage	V _{IN}	—	0~5.5	V
Output Voltage	V _{OUT}	—	0~V _{CC}	V
Operating Temperature Range	T _{opr}	—	-40~+85	°C
Output Current	I _{OH}	3.0	-4	mA
		4.5	-8	
	I _{OL}	3.0	4	
		4.5	8	
Input Rise and Fall Time	t _{r,tf}	3.3	0~100	ns
		5.0	0~20	

DC ELECTRICAL CHARACTERISTICS

PARAMETER	SYMBOL	V _{CC} (V)	CONDITIONS	Ta=25°C			Ta=-40°C~85°C		UNITS	
				MIN.	TYP.	MAX.	MIN.	MAX.		
Input Voltage	V _{IH}	2.0		1.5	—	—	1.5	—	V	
		3.0		2.1	—	—	2.1	—		
		5.5		3.85	—	—	3.85	—		
	V _{IL}	2.0		—	—	0.5	—	0.5	V	
		3.0		—	—	0.9	—	0.9		
		5.5		—	—	1.65	—	1.65		
Output Voltage	V _{OH}	2.0	V _{IN} =V _{IH} or V _{IL}	I _{OH} =-50 μA	1.9	2.0	—	1.9	—	V
		3.0			2.9	3.0	—	2.9	—	
		4.5		4.4	4.5	—	4.4	—		
		3.0		I _{OH} =-4mA	2.58	—	—	2.48	—	
		4.5			I _{OH} =-8mA	3.94	—	—	3.80	
	V _{OL}	2.0	V _{IN} =V _{IL}	I _{OL} =50 μA		—	—	0.1	—	0.1
		3.0			—	—	0.1	—	0.1	
		4.5		—	—	0.1	—	0.1		
		3.0		I _{OL} =4mA	—	—	0.36	—	0.44	
		4.5			I _{OL} =8mA	—	—	0.36	—	0.44
Input Current	I _{IN}	5.5	V _{IN} =V _{CC} or GND	-0.1		—	0.1	-1.0	1.0	μA
Static Supply Current	I _{CC}	5.5	V _{IN} =V _{CC} or GND, I _{OUT} =0 μA	—	—	1.0	—	10.0		

SWITCHING ELECTRICAL CHARACTERISTICS

t_r=t_f=3ns

PARAMETER	SYMBOL	C _L	V _{CC} (V)	CONDITIONS	Ta=25°C			Ta=-40°C~85°C		UNITS
					MIN.	TYP.	MAX.	MIN.	MAX.	
Delay Time	t _{PLH}	15pF	3.3		—	5.5	7.9	1.0	9.5	ns
			5.0		—	3.8	5.5	1.0	6.5	
		50pF	3.3		—	8.0	11.4	1.0	13.0	ns
			5.0		—	5.3	7.5	1.0	8.5	
	t _{PHL}	15pF	3.3		—	5.5	7.9	1.0	9.5	ns
			5.0		—	3.8	5.5	1.0	6.5	
		50pF	3.3		—	8.0	11.4	1.0	13.0	ns
			5.0		—	5.3	7.5	1.0	8.5	
Input Capacitance	C _{IN}	—	5.0	V _{IN} =V _{CC} or GND	—	2	10	—	10	pF
Power Dissipation Capacitance	C _{pd}	No Load, f=1MHz			—	8.9	—	—	—	pF

■ WAVEFORM

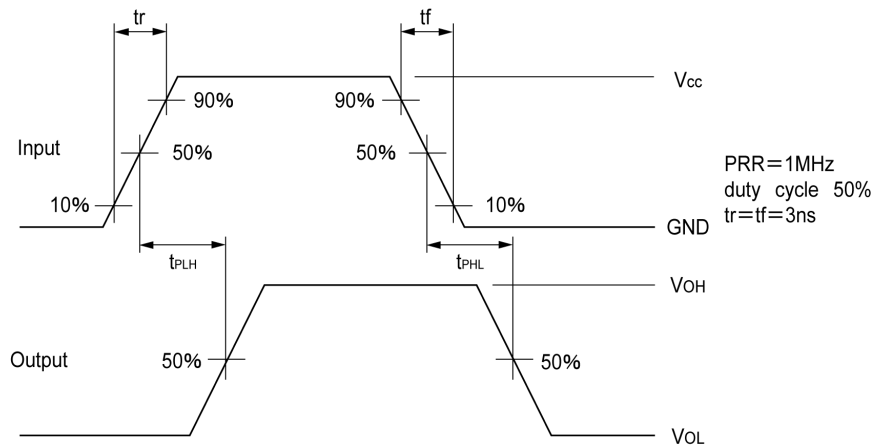

■ TEST CIRCUIT

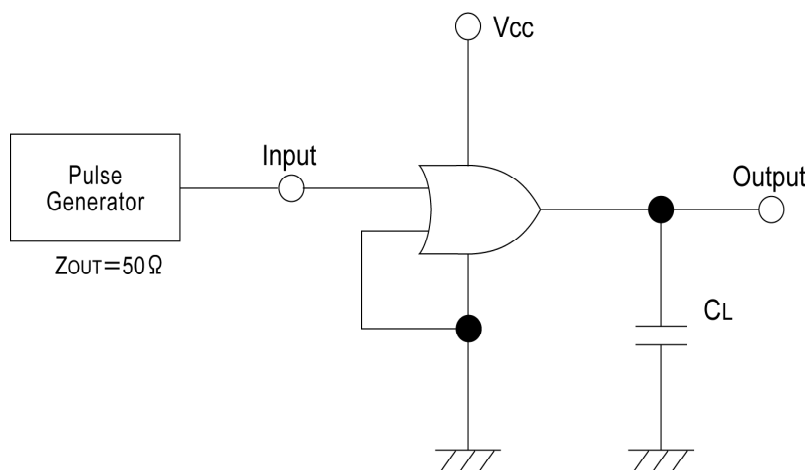

Note: Open output when measuring supply current