

HM10470, HM10470-1

4096-word x 1-bit Fully Decoded Random Access Memory
 The HM10470 is ECL 10K compatible, 4096-words x 1-bit, read write random access memory developed for high speed systems such as scratch pads and control/buffer storages.

The fabrication process is the Hitachi's low capacitance, oxide isolation method with double metalization.

The HM10470 is encapsulated in cerdip-18 pin package, compatible with Fairchild's F10470.

■ FEATURES

- 4096-word x 1-bit organization
- Fully compatible with 10K ECL level
- Address access time:

HM10470	25ns (max)
HM10470-1	15ns (max)
- Write pulse width:

HM10470	25ns (min)
HM10470-1	15ns (min)
- Low power dissipation: 0.2mW/bit
- Output obtainable by wired-OR (open emitter)

■ TRUTH TABLE

CS	Input		Output	Mode
	WE	Din		
H	x	x	L	Not Selected
L	L	L	L	Write "0"
L	L	H	L	Write "1"
L	H	x	Dout*	Read

Notes: x : Irrelevant
 * : Read Out Noninvert

■ BLOCK DIAGRAM

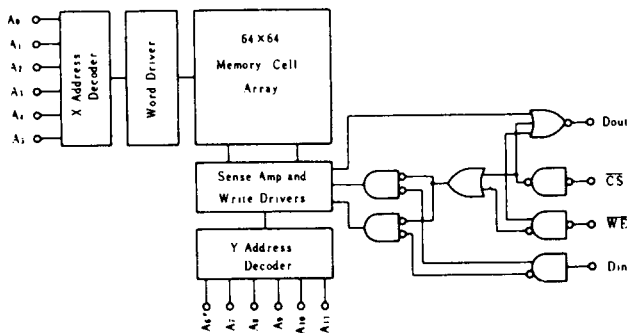

■ ABSOLUTE MAXIMUM RATINGS (Ta = 25°C)

Item	Symbol	Rating	Unit
Supply Voltage	V _{EE} to V _{CC}	+0.5 to -7.0	V
Input Voltage	V _{in}	+0.5 to V _{EE}	V
Output Current	I _{out}	-30	mA
Storage Temperature	T _{stg}	-65 to +150	°C
Storage Temperature	T _{stg} (Bias)*	-55 to +125	°C

* Under Bias

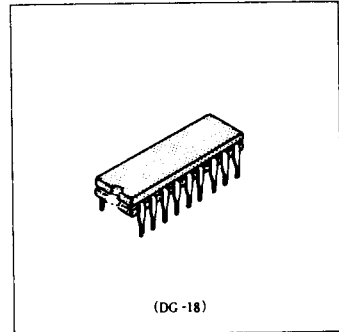

■ PIN ARRANGEMENT

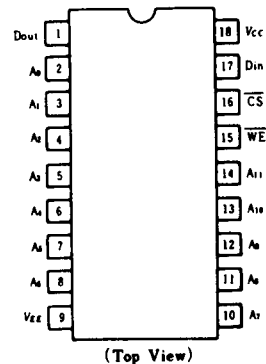

■ ELECTRICAL CHARACTERISTICS

● DC CHARACTERISTICS ($V_{EE} = -5.2V$, $R_L = 50\Omega$ to $-2.0V$, $T_a = 0$ to $+75^\circ C$, air flow exceeding 2m/sec)

Item	Symbol	Test Condition	min(B)			typ	max(A)	Unit	
			0°C	+25°C	+75°C				
Output Voltage	V_{OH}	$V_{IN} = V_{IH}$ or V_{IL}	0°C	-1000	-	-	-840	mV	
			+25°C	-960	-	-	-810		
			+75°C	-900	-	-	-720		
	V_{OL}		0°C	-1870	-	-	-1665		
			+25°C	-1850	-	-	-1650		
			+75°C	-1830	-	-	-1625		
Output Threshold Voltage	V_{OHc}	$V_{IN} = V_{IH}$ or V_{IL}	0°C	-1020	-	-	-	mV	
			+25°C	-980	-	-	-		
			+75°C	-920	-	-	-		
	V_{OLc}		0°C	-	-	-	-1645		
			+25°C	-	-	-	-1630		
			+75°C	-	-	-	-1605		
Input Voltage	V_{IH}	Guaranteed Input Voltage High for All Inputs	0°C	-1145	-	-	-840	mV	
			+25°C	-1105	-	-	-810		
			+75°C	-1045	-	-	-720		
	V_{IL}		0°C	-1870	-	-	-1490		
			+25°C	-1850	-	-	-1475		
			+75°C	-1830	-	-	-1450		
Input Current	I_{IH}	$V_{IN} = V_{IH}$	0 to +75°C	-	-	-	220	μA	
				CS	$V_{IN} = V_{IL}$	0 to +75°C	0.5		-
	Other					-	-		-
Supply Current	I_{EE}	All Input and Output Open, Test Pin 9	$T_a = 0^\circ C$	-200*		-160*	-	-	mA
				-280**	-200**	-	-		
				$T_a = 75^\circ C$	-	-145	-	-	

* HM10470
 ** HM10470-1

● AC CHARACTERISTICS ($V_{EE} = -5.2V \pm 5\%$, $T_a = 0$ to $+75^\circ C$, air flow exceeding 2m/sec)

1. READ MODE

Item	Symbol	Test Condition	HM10470			HM10470-1			Unit
			min	typ	max	min	typ	max	
Chip Select Access Time	t_{ACS}		-	-	10	-	-	8	ns
Chip Select Recovery Time	t_{RCS}		-	-	10	-	-	8	ns
Address Access Time	t_{AA}		-	15	25	-	12	15	ns

2. WRITE MODE

Item	Symbol	Test Condition	HM10470			HM10470-1			Unit
			min	typ	max	min	typ	max	
Write Pulse Width	t_w	$t_{WSA} = 3ns$	25	-	-	15	-	-	ns
Data Setup Time	t_{WSD}		2	-	-	2	-	-	ns
Data Hold Time	t_{WHD}		2	-	-	2	-	-	ns
Address Setup Time	t_{WSA}		$t_w = t_{wmax}$	3	-	-	3	-	-
Address Hold Time	t_{WHA}		2	-	-	2	-	-	ns
Chip Select Setup Time	t_{WSCS}		2	-	-	2	-	-	ns
Chip Select Hold Time	t_{WNCS}		2	-	-	2	-	-	ns
Write Disable Time	t_{WSD}		-	-	10	-	-	8	ns
Write Recovery Time	t_{WR}		-	-	27	-	-	17	ns



3. RISE/FALL TIME

Item	Symbol	Test Condition	min	typ	max	Unit
Output Rise Time	t_r		—	2	—	ns
Output Fall Time	t_f		—	2	—	ns

4. CAPACITANCE

Item	Symbol	Test Condition	min	typ	max	Unit
Input Capacitance	C_{in}		—	3	—	pF
Output Capacitance	C_{out}		—	5	—	pF

■ TEST CIRCUIT AND WAVEFORMS

1. LOADING CONDITION

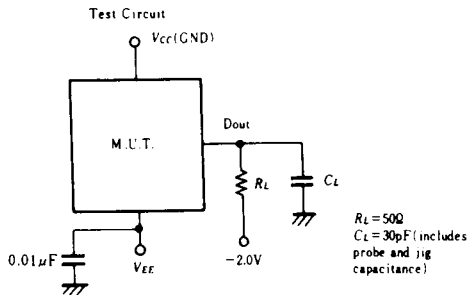

2. INPUT PULSE

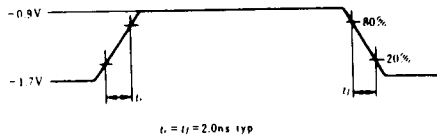

3. READ MODE

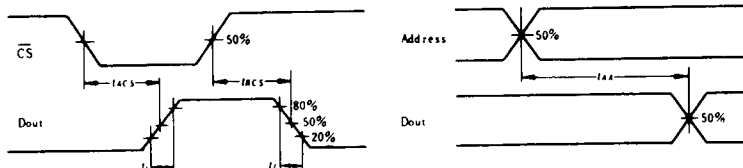

4. WRITE MODE

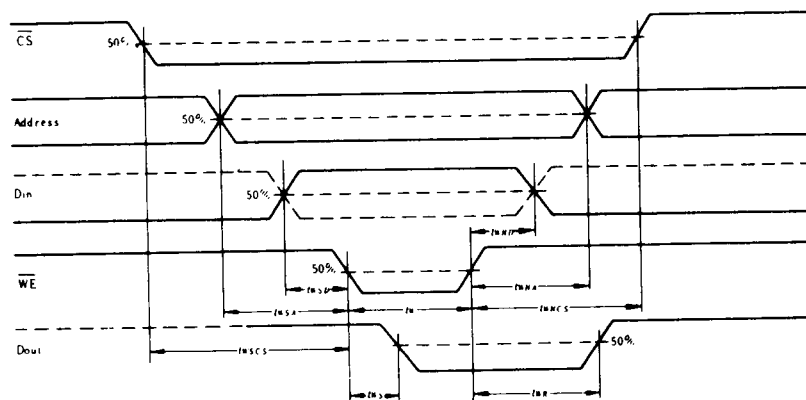

SUPPLY CURRENT vs. AMBIENT TEMPERATURE

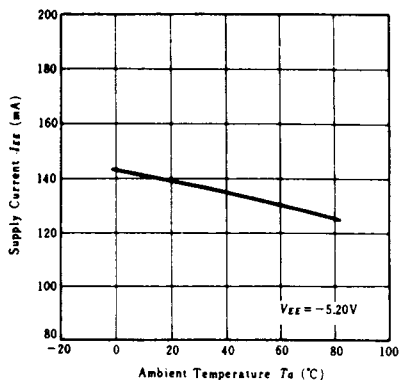

SUPPLY CURRENT vs. SUPPLY VOLTAGE

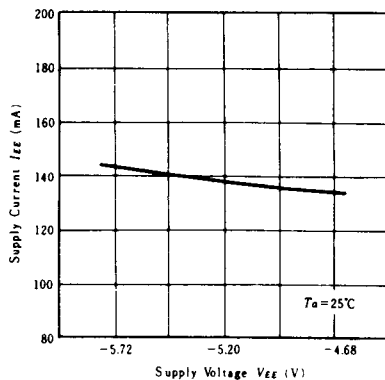

ADDRESS ACCESS TIME vs. AMBIENT TEMPERATURE

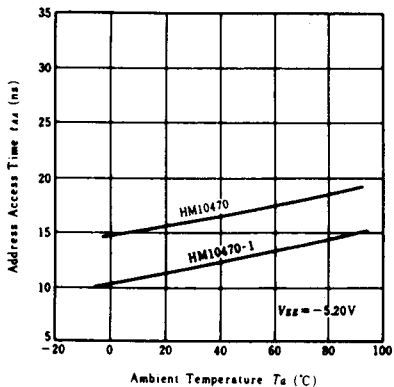

ADDRESS ACCESS TIME vs. SUPPLY VOLTAGE

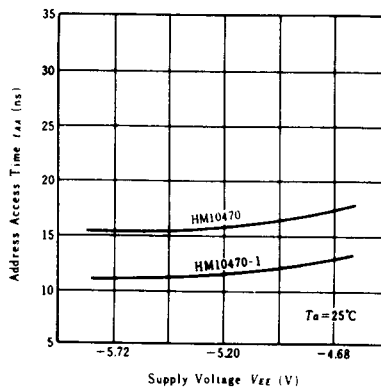

CHIP SELECT ACCESS TIME vs. AMBIENT TEMPERATURE

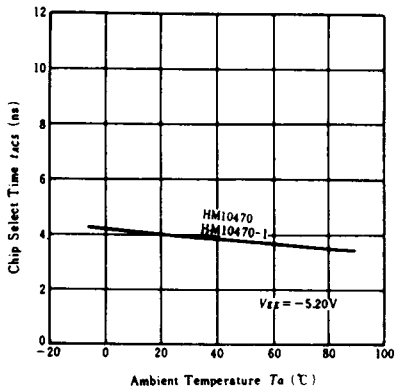

CHIP SELECT ACCESS TIME vs. SUPPLY VOLTAGE

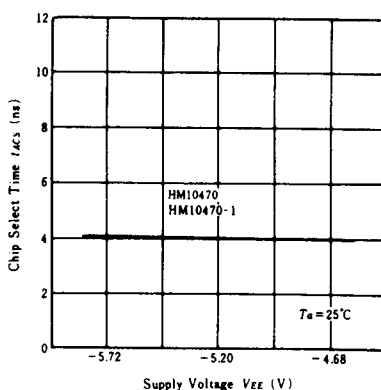

**WRITE PULSE WIDTH vs.
AMBIENT TEMPERATURE**

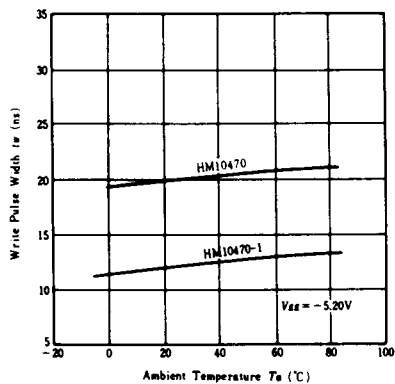

**WRITE PULSE WIDTH vs.
SUPPLY VOLTAGE**

