

Rochester Electronics Manufactured Components

Rochester branded components are manufactured using either die/wafers purchased from the original suppliers or Rochester wafers recreated from the original IP. All recreations are done with the approval of the OCM.

Parts are tested using original factory test programs or Rochester developed test solutions to guarantee product meets or exceed the OCM data sheet.

Quality Overview

- ISO-9001
- AS9120 certification
- Qualified Manufacturers List (QML) MIL-PRF-35835
 - Class Q Military
 - Class V Space Level
- Qualified Suppliers List of Distributors (QSLD)
 - Rochester is a critical supplier to DLA and meets all industry and DLA standards.

Rochester Electronics, LLC is committed to supplying products that satisfy customer expectations for quality and are equal to those originally supplied by industry manufacturers.

The original manufacturer's datasheet accompanying this document reflects the performance and specifications of the Rochester manufactured version of this device. Rochester Electronics guarantees the performance of its semiconductor products to the original OEM specifications. 'Typical' values are for reference purposes only. Certain minimum or maximum ratings may be based on product characterization, design, simulation, or sample testing.

TL494, NCV494

SWITCHMODE™ Pulse Width Modulation Control Circuit

The TL494 is a fixed frequency, pulse width modulation control circuit designed primarily for SWITCHMODE power supply control.

- Complete Pulse Width Modulation Control Circuitry
- On-Chip Oscillator with Master or Slave Operation
- On-Chip Error Amplifiers
- On-Chip 5.0 V Reference
- Adjustable Deadtime Control
- Uncommitted Output Transistors Rated to 500 mA Source or Sink
- Output Control for Push-Pull or Single-Ended Operation
- Undervoltage Lockout
- NCV Prefix for Automotive and Other Applications Requiring Site and Control Changes

MAXIMUM RATINGS (Full operating ambient temperature range applies, unless otherwise noted.)

Rating	Symbol	Value	Unit
Power Supply Voltage	V_{CC}	42	V
Collector Output Voltage	V_{C1} , V_{C2}	42	V
Collector Output Current (Each transistor) (Note 1)	I_{C1} , I_{C2}	500	mA
Amplifier Input Voltage Range	V_{IR}	-0.3 to +42	V
Power Dissipation @ $T_A \leq 45^\circ\text{C}$	P_D	1000	mW
Thermal Resistance, Junction-to-Ambient	$R_{\theta JA}$	80	$^\circ\text{C}/\text{W}$
Operating Junction Temperature	T_J	125	$^\circ\text{C}$
Storage Temperature Range	T_{stg}	-55 to +125	$^\circ\text{C}$
Operating Ambient Temperature Range TL494B TL494C TL494I NCV494B	T_A	-40 to +125 0 to +70 -40 to +85 -40 to +125	$^\circ\text{C}$
Derating Ambient Temperature	T_A	45	$^\circ\text{C}$

1. Maximum thermal limits must be observed.

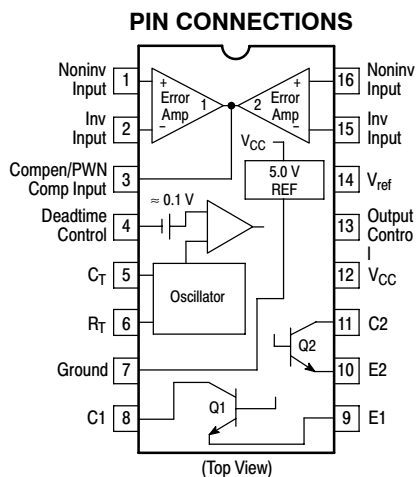

ON Semiconductor®

<http://onsemi.com>

MARKING DIAGRAMS

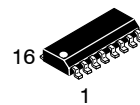

SO-16
D SUFFIX
CASE 751B

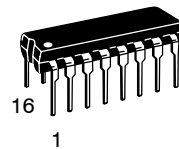

PDIP-16
N SUFFIX
CASE 648

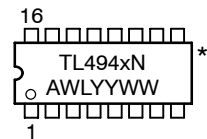

x = B, C or I
A = Assembly Location
WL, L = Wafer Lot
YY, Y = Year
WW, W = Work Week

*This marking diagram also applies to NCV494.

ORDERING INFORMATION

Device	Package	Shipping†
TL494BD	SO-16	48 Units/Rail
TL494BDR2	SO-16	2500 Tape & Reel
TL494CD	SO-16	48 Units/Rail
TL494CDR2	SO-16	2500 Tape & Reel
TL494CN	PDIP-16	25 Units/Rail
TL494IN	PDIP-16	25 Units/Rail
NCV494BDR2*	SO-16	2500 Tape & Reel

†For information on tape and reel specifications, including part orientation and tape sizes, please refer to our Tape and Reel Packaging Specification Brochure, BRD8011/D.

*NCV494: $T_{low} = -40^\circ\text{C}$, $T_{high} = +125^\circ\text{C}$.
Guaranteed by design. NCV prefix is for automotive and other applications requiring site and change control.

TL494, NCV494

RECOMMENDED OPERATING CONDITIONS

Characteristics	Symbol	Min	Typ	Max	Unit
Power Supply Voltage	V_{CC}	7.0	15	40	V
Collector Output Voltage	V_{C1}, V_{C2}	–	30	40	V
Collector Output Current (Each transistor)	I_{C1}, I_{C2}	–	–	200	mA
Amplified Input Voltage	V_{in}	–0.3	–	$V_{CC} - 2.0$	V
Current Into Feedback Terminal	I_{fb}	–	–	0.3	mA
Reference Output Current	I_{ref}	–	–	10	mA
Timing Resistor	R_T	1.8	30	500	k Ω
Timing Capacitor	C_T	0.0047	0.001	10	μ F
Oscillator Frequency	f_{osc}	1.0	40	200	kHz

ELECTRICAL CHARACTERISTICS ($V_{CC} = 15$ V, $C_T = 0.01$ μ F, $R_T = 12$ k Ω , unless otherwise noted.)

For typical values $T_A = 25^\circ\text{C}$, for min/max values T_A is the operating ambient temperature range that applies, unless otherwise noted.

Characteristics	Symbol	Min	Typ	Max	Unit
-----------------	--------	-----	-----	-----	------

REFERENCE SECTION

Reference Voltage ($I_O = 1.0$ mA)	V_{ref}	4.75	5.0	5.25	V
Line Regulation ($V_{CC} = 7.0$ V to 40 V)	Reg_{line}	–	2.0	25	mV
Load Regulation ($I_O = 1.0$ mA to 10 mA)	Reg_{load}	–	3.0	15	mV
Short Circuit Output Current ($V_{ref} = 0$ V)	I_{SC}	15	35	75	mA

OUTPUT SECTION

Collector Off-State Current ($V_{CC} = 40$ V, $V_{CE} = 40$ V)	$I_{C(off)}$	–	2.0	100	μ A
Emitter Off-State Current $V_{CC} = 40$ V, $V_C = 40$ V, $V_E = 0$ V)	$I_{E(off)}$	–	–	–100	μ A
Collector-Emitter Saturation Voltage (Note 2) Common-Emitter ($V_E = 0$ V, $I_C = 200$ mA) Emitter-Follower ($V_C = 15$ V, $I_E = -200$ mA)	$V_{sat(C)}$ $V_{sat(E)}$	– –	1.1 1.5	1.3 2.5	V
Output Control Pin Current Low State ($V_{OC} \leq 0.4$ V) High State ($V_{OC} = V_{ref}$)	I_{OCL} I_{OCH}	– –	10 0.2	– 3.5	μ A mA
Output Voltage Rise Time Common-Emitter (See Figure 12) Emitter-Follower (See Figure 13)	t_r	– –	100 100	200 200	ns
Output Voltage Fall Time Common-Emitter (See Figure 12) Emitter-Follower (See Figure 13)	t_f	– –	25 40	100 100	ns

2. Low duty cycle pulse techniques are used during test to maintain junction temperature as close to ambient temperature as possible.

TL494, NCV494

ELECTRICAL CHARACTERISTICS ($V_{CC} = 15\text{ V}$, $C_T = 0.01\ \mu\text{F}$, $R_T = 12\ \text{k}\Omega$, unless otherwise noted.)

For typical values $T_A = 25^\circ\text{C}$, for min/max values T_A is the operating ambient temperature range that applies, unless otherwise noted.

Characteristics	Symbol	Min	Typ	Max	Unit
-----------------	--------	-----	-----	-----	------

ERROR AMPLIFIER SECTION

Input Offset Voltage (V_O (Pin 3) = 2.5 V)	V_{IO}	–	2.0	10	mV
Input Offset Current (V_O (Pin 3) = 2.5 V)	I_{IO}	–	5.0	250	nA
Input Bias Current (V_O (Pin 3) = 2.5 V)	I_{IB}	–	–0.1	–1.0	μA
Input Common Mode Voltage Range ($V_{CC} = 40\text{ V}$, $T_A = 25^\circ\text{C}$)	V_{ICR}	–0.3 to $V_{CC}-2.0$			V
Open Loop Voltage Gain ($\Delta V_O = 3.0\text{ V}$, $V_O = 0.5\text{ V}$ to 3.5 V , $R_L = 2.0\ \text{k}\Omega$)	A_{VOL}	70	95	–	dB
Unity-Gain Crossover Frequency ($V_O = 0.5\text{ V}$ to 3.5 V , $R_L = 2.0\ \text{k}\Omega$)	f_{C-}	–	350	–	kHz
Phase Margin at Unity-Gain ($V_O = 0.5\text{ V}$ to 3.5 V , $R_L = 2.0\ \text{k}\Omega$)	ϕ_m	–	65	–	deg.
Common Mode Rejection Ratio ($V_{CC} = 40\text{ V}$)	CMRR	65	90	–	dB
Power Supply Rejection Ratio ($\Delta V_{CC} = 33\text{ V}$, $V_O = 2.5\text{ V}$, $R_L = 2.0\ \text{k}\Omega$)	PSRR	–	100	–	dB
Output Sink Current (V_O (Pin 3) = 0.7 V)	I_{O-}	0.3	0.7	–	mA
Output Source Current (V_O (Pin 3) = 3.5 V)	I_{O+}	2.0	–4.0	–	mA

PWM COMPARATOR SECTION (Test Circuit Figure 11)

Input Threshold Voltage (Zero Duty Cycle)	V_{TH}	–	2.5	4.5	V
Input Sink Current ($V_{(Pin\ 3)} = 0.7\text{ V}$)	I_{I-}	0.3	0.7	–	mA

DEADTIME CONTROL SECTION (Test Circuit Figure 11)

Input Bias Current (Pin 4) ($V_{Pin\ 4} = 0\text{ V}$ to 5.25 V)	I_{IB} (DT)	–	–2.0	–10	μA
Maximum Duty Cycle, Each Output, Push-Pull Mode ($V_{Pin\ 4} = 0\text{ V}$, $C_T = 0.01\ \mu\text{F}$, $R_T = 12\ \text{k}\Omega$) ($V_{Pin\ 4} = 0\text{ V}$, $C_T = 0.001\ \mu\text{F}$, $R_T = 30\ \text{k}\Omega$)	DC_{max}	45 –	48 45	50 50	%
Input Threshold Voltage (Pin 4) (Zero Duty Cycle) (Maximum Duty Cycle)	V_{th}	– 0	2.8 –	3.3 –	V

OSCILLATOR SECTION

Frequency ($C_T = 0.001\ \mu\text{F}$, $R_T = 30\ \text{k}\Omega$)	f_{osc}	–	40	–	kHz
Standard Deviation of Frequency* ($C_T = 0.001\ \mu\text{F}$, $R_T = 30\ \text{k}\Omega$)	σ_{osc}	–	3.0	–	%
Frequency Change with Voltage ($V_{CC} = 7.0\text{ V}$ to 40 V , $T_A = 25^\circ\text{C}$)	Δf_{osc} (ΔV)	–	0.1	–	%
Frequency Change with Temperature ($\Delta T_A = T_{low}$ to T_{high}) ($C_T = 0.01\ \mu\text{F}$, $R_T = 12\ \text{k}\Omega$)	Δf_{osc} (ΔT)	–	–	12	%

UNDERVOLTAGE LOCKOUT SECTION

Turn-On Threshold (V_{CC} increasing, $I_{ref} = 1.0\text{ mA}$)	V_{th}	5.5	6.43	7.0	V
--	----------	-----	------	-----	---

TOTAL DEVICE

Standby Supply Current (Pin 6 at V_{ref} , All other inputs and outputs open) ($V_{CC} = 15\text{ V}$) ($V_{CC} = 40\text{ V}$)	I_{CC}	– –	5.5 7.0	10 15	mA
Average Supply Current ($C_T = 0.01\ \mu\text{F}$, $R_T = 12\ \text{k}\Omega$, $V_{(Pin\ 4)} = 2.0\text{ V}$) ($V_{CC} = 15\text{ V}$) (See Figure 12)		–	7.0	–	mA

* Standard deviation is a measure of the statistical distribution about the mean as derived from the formula, $\sigma = \sqrt{\frac{\sum_{n=1}^N (X_n - \bar{X})^2}{N - 1}}$

TL494, NCV494

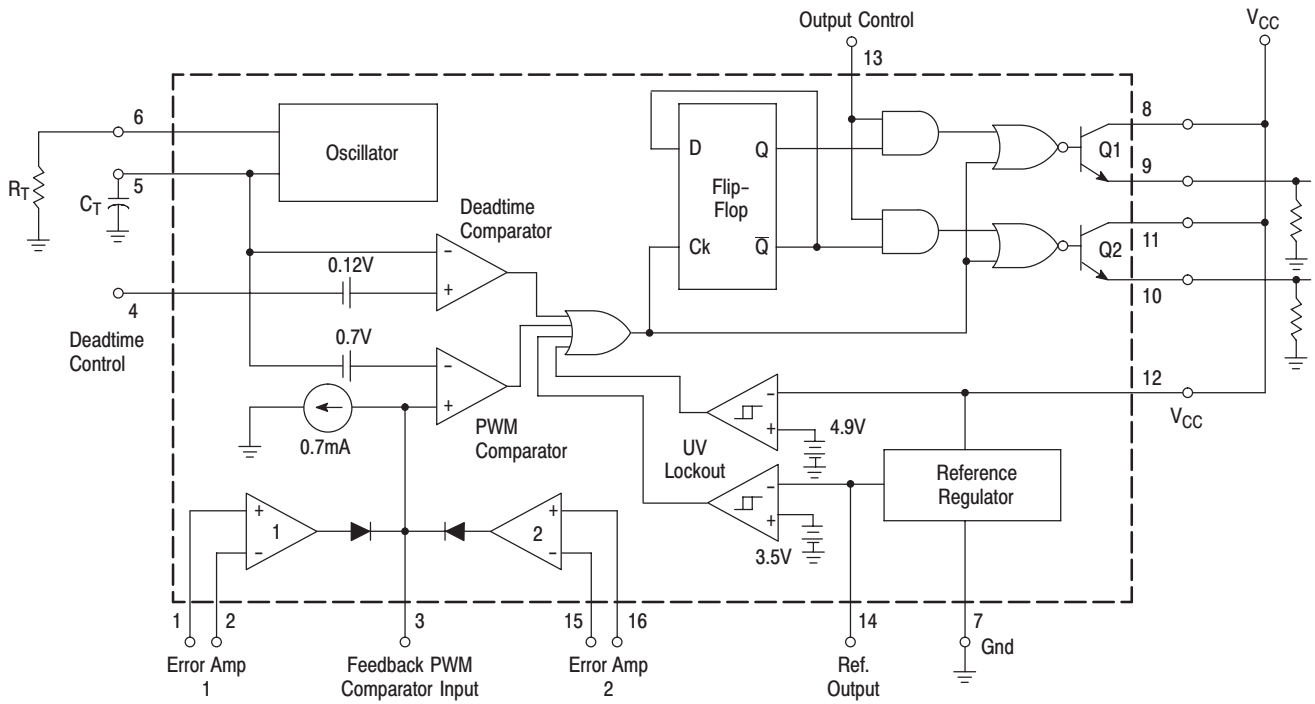

This device contains 46 active transistors.

Figure 1. Representative Block Diagram

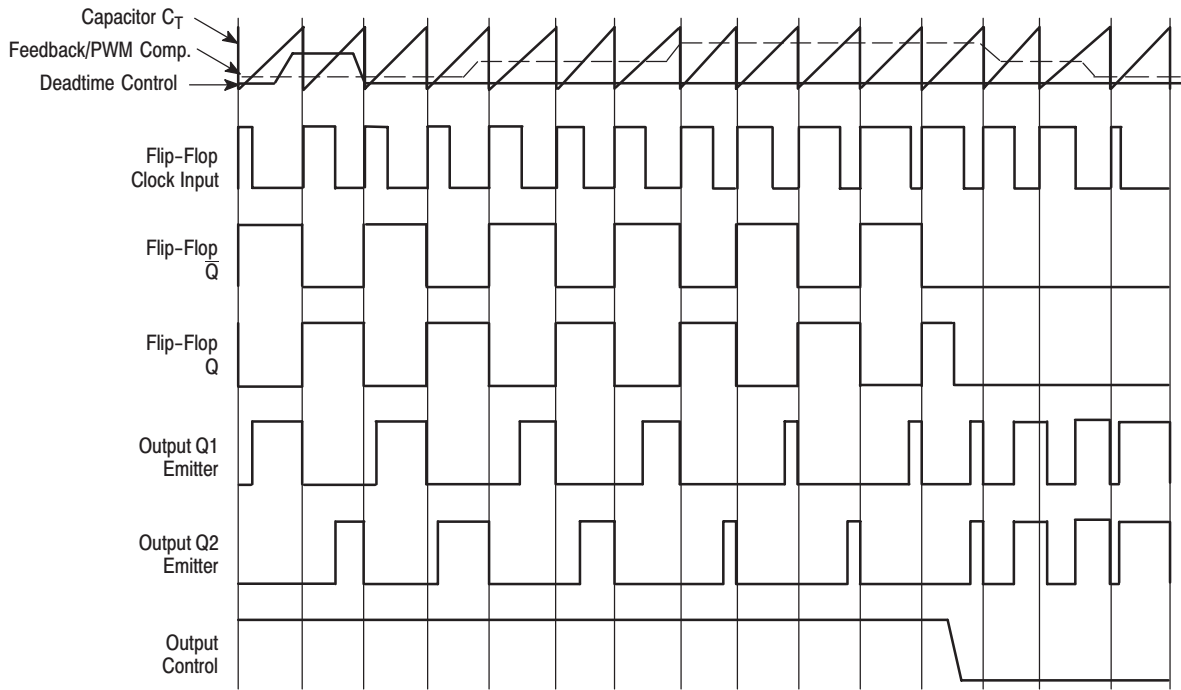

Figure 2. Timing Diagram

APPLICATIONS INFORMATION

Description

The TL494 is a fixed-frequency pulse width modulation control circuit, incorporating the primary building blocks required for the control of a switching power supply. (See Figure 1.) An internal-linear sawtooth oscillator is frequency-programmable by two external components, R_T and C_T . The approximate oscillator frequency is determined by:

$$f_{osc} \approx \frac{1.1}{R_T \cdot C_T}$$

For more information refer to Figure 3.

Output pulse width modulation is accomplished by comparison of the positive sawtooth waveform across capacitor C_T to either of two control signals. The NOR gates, which drive output transistors Q1 and Q2, are enabled only when the flip-flop clock-input line is in its low state. This happens only during that portion of time when the sawtooth voltage is greater than the control signals. Therefore, an increase in control-signal amplitude causes a corresponding linear decrease of output pulse width. (Refer to the Timing Diagram shown in Figure 2.)

The control signals are external inputs that can be fed into the deadtime control, the error amplifier inputs, or the feedback input. The deadtime control comparator has an effective 120 mV input offset which limits the minimum output deadtime to approximately the first 4% of the sawtooth-cycle time. This would result in a maximum duty cycle on a given output of 96% with the output control grounded, and 48% with it connected to the reference line. Additional deadtime may be imposed on the output by setting the deadtime-control input to a fixed voltage, ranging between 0 V to 3.3 V.

Functional Table

Input/Output Controls	Output Function	$\frac{f_{out}}{f_{osc}} =$
Grounded	Single-ended PWM @ Q1 and Q2	1.0
@ V_{ref}	Push-pull Operation	0.5

The pulse width modulator comparator provides a means for the error amplifiers to adjust the output pulse width from the maximum percent on-time, established by the deadtime control input, down to zero, as the voltage at the feedback pin varies from 0.5 V to 3.5 V. Both error amplifiers have a

common mode input range from -0.3 V to ($V_{CC} - 2V$), and may be used to sense power-supply output voltage and current. The error-amplifier outputs are active high and are ORed together at the noninverting input of the pulse-width modulator comparator. With this configuration, the amplifier that demands minimum output on time, dominates control of the loop.

When capacitor C_T is discharged, a positive pulse is generated on the output of the deadtime comparator, which clocks the pulse-steering flip-flop and inhibits the output transistors, Q1 and Q2. With the output-control connected to the reference line, the pulse-steering flip-flop directs the modulated pulses to each of the two output transistors alternately for push-pull operation. The output frequency is equal to half that of the oscillator. Output drive can also be taken from Q1 or Q2, when single-ended operation with a maximum on-time of less than 50% is required. This is desirable when the output transformer has a ringback winding with a catch diode used for snubbing. When higher output-drive currents are required for single-ended operation, Q1 and Q2 may be connected in parallel, and the output-mode pin must be tied to ground to disable the flip-flop. The output frequency will now be equal to that of the oscillator.

The TL494 has an internal 5.0 V reference capable of sourcing up to 10 mA of load current for external bias circuits. The reference has an internal accuracy of $\pm 5.0\%$ with a typical thermal drift of less than 50 mV over an operating temperature range of 0° to 70°C.

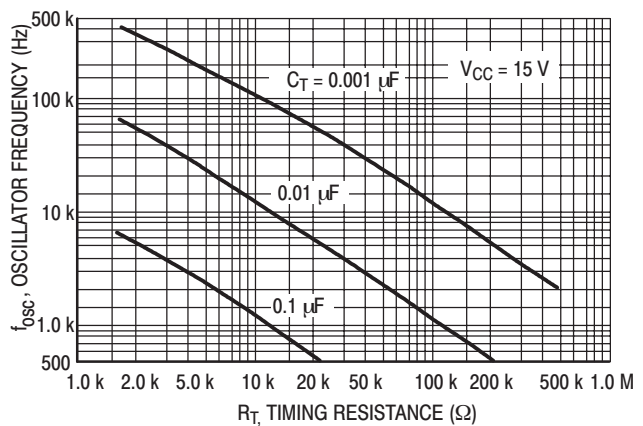

Figure 3. Oscillator Frequency versus Timing Resistance

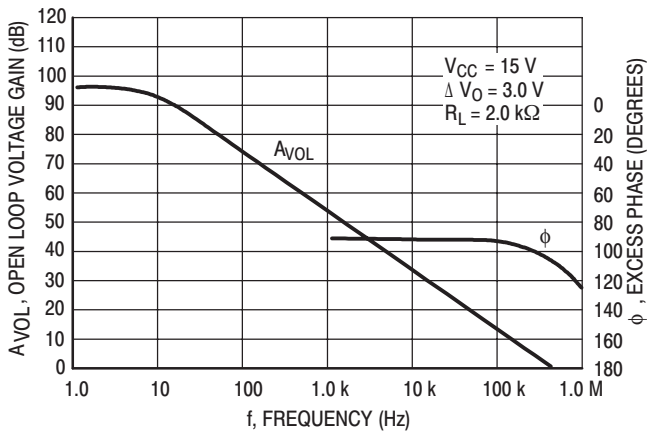

Figure 4. Open Loop Voltage Gain and Phase versus Frequency

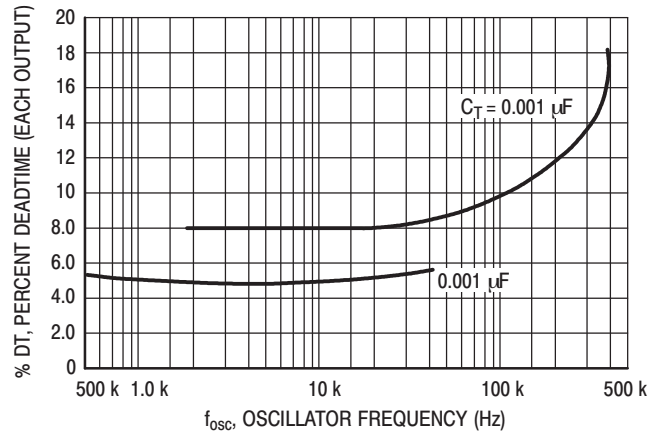

Figure 5. Percent Deadtime versus Oscillator Frequency

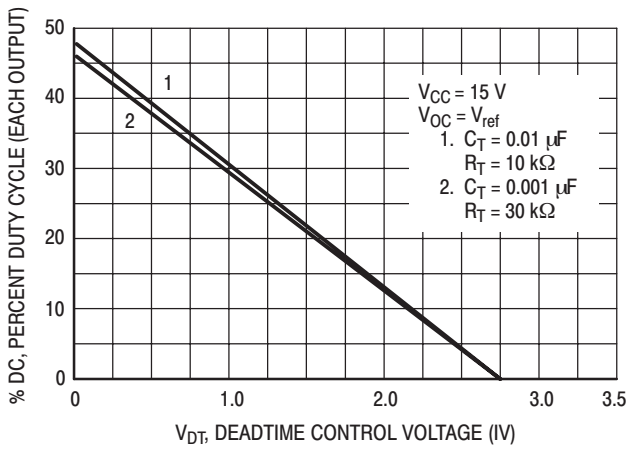

Figure 6. Percent Duty Cycle versus Deadtime Control Voltage

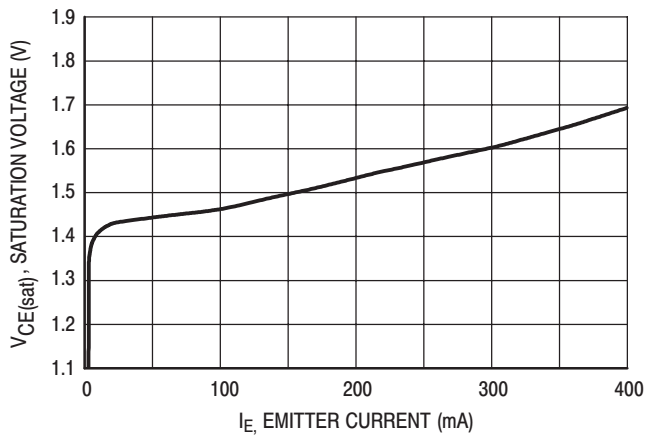

Figure 7. Emitter-Follower Configuration Output Saturation Voltage versus Emitter Current

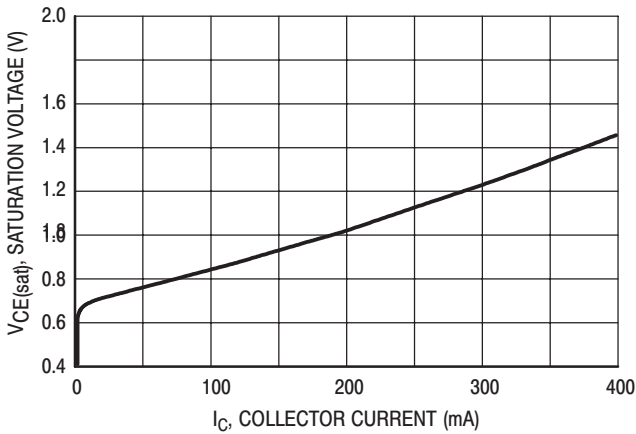

Figure 8. Common-Emitter Configuration Output Saturation Voltage versus Collector Current

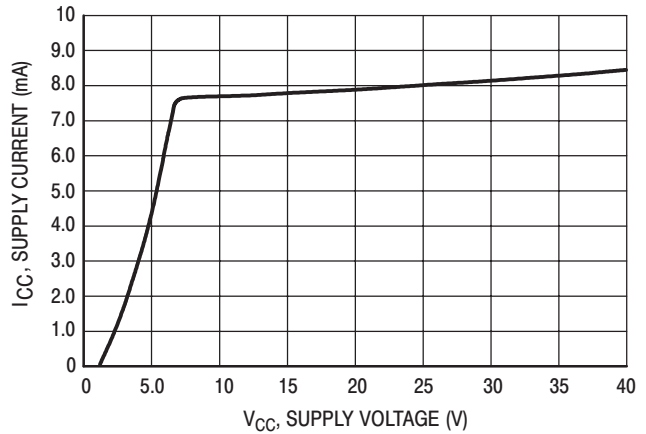

Figure 9. Standby Supply Current versus Supply Voltage

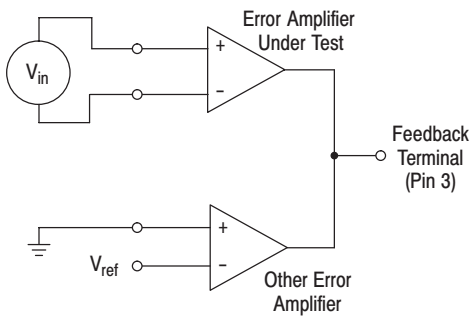

Figure 10. Error-Amplifier Characteristics

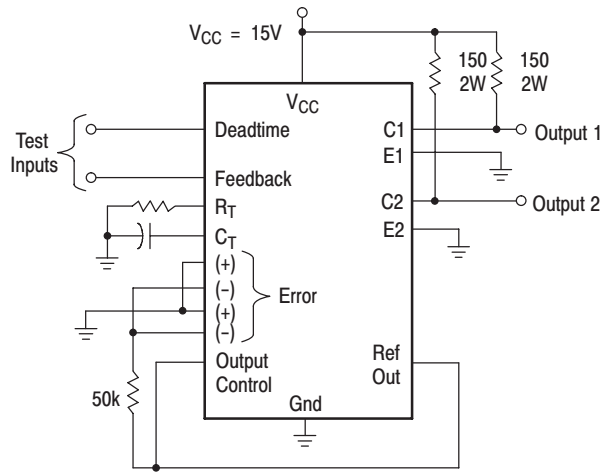

Figure 11. Deadtime and Feedback Control Circuit

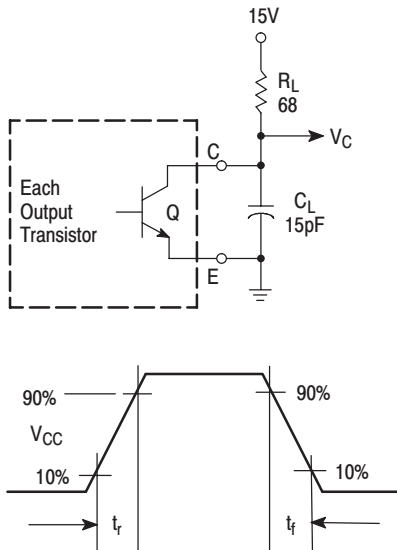

Figure 12. Common-Emitter Configuration Test Circuit and Waveform

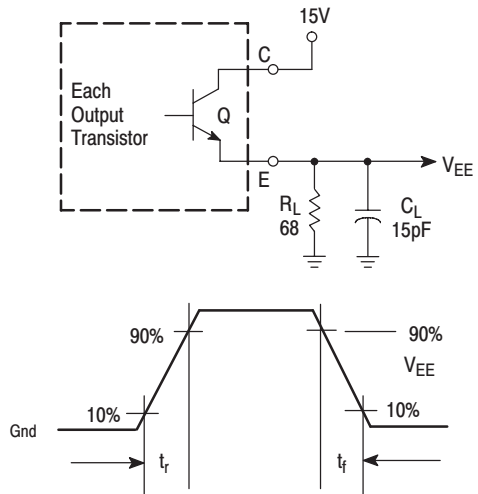

Figure 13. Emitter-Follower Configuration Test Circuit and Waveform

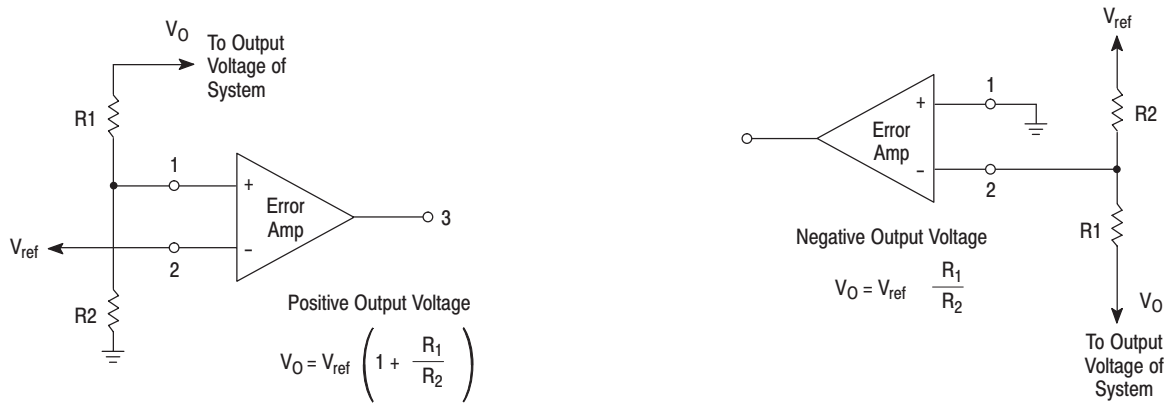
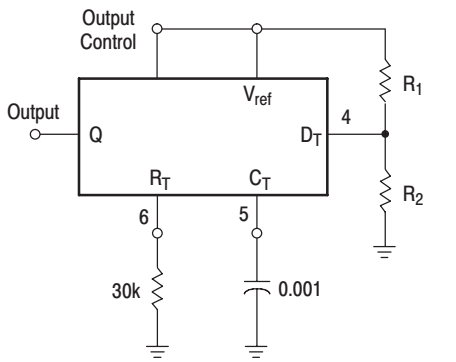

Figure 14. Error-Amplifier Sensing Techniques



$$\text{Max. \% on Time, each output} \approx 45 - \left(\frac{80}{1 + \frac{R_1}{R_2}} \right)$$

Figure 15. Deadtime Control Circuit

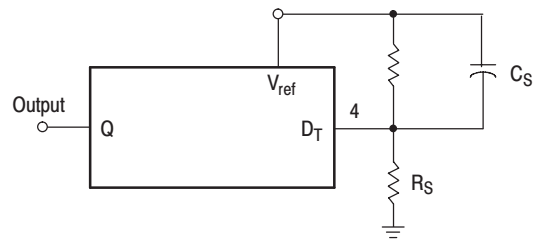

Figure 16. Soft-Start Circuit

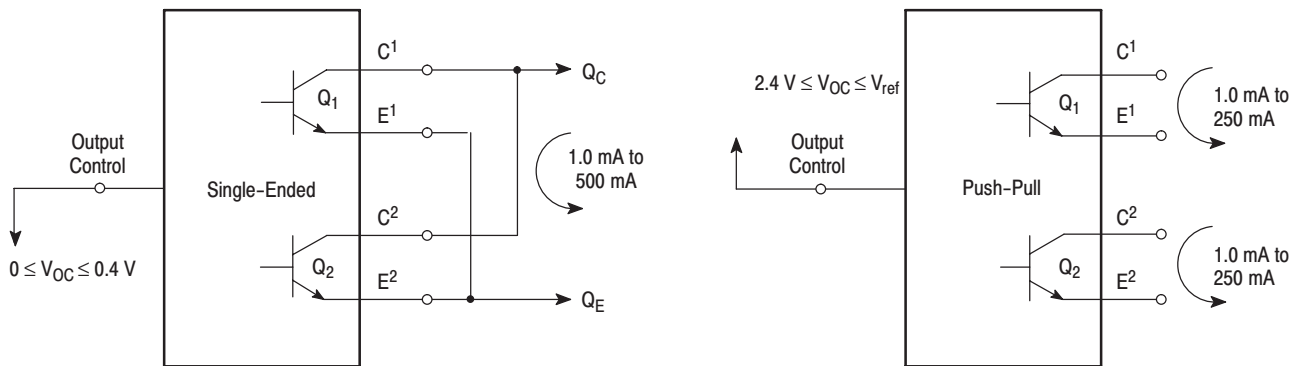

Figure 17. Output Connections for Single-Ended and Push-Pull Configurations

TL494, NCV494

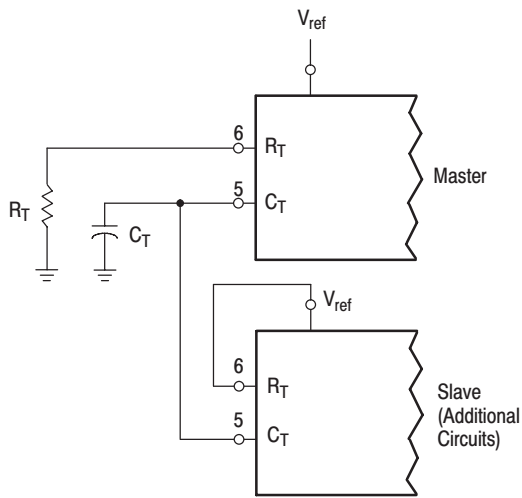

Figure 18. Slaving Two or More Control Circuits

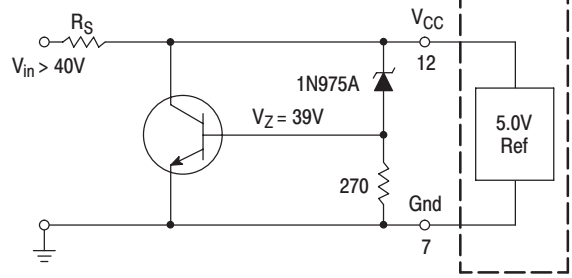

Figure 19. Operation with $V_{in} > 40\text{ V}$ Using External Zener

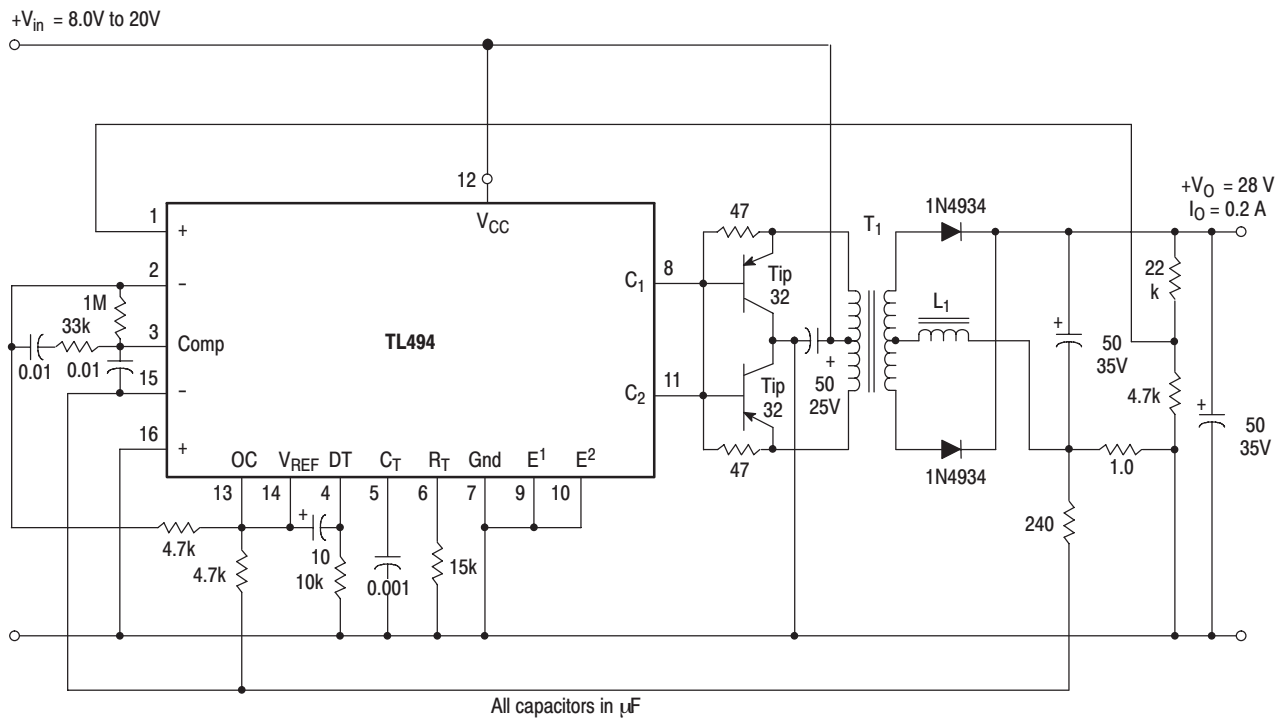

Figure 20. Pulse Width Modulated Push-Pull Converter

Test	Conditions	Results
Line Regulation	$V_{in} = 10\text{ V to }40\text{ V}$	14 mV 0.28%
Load Regulation	$V_{in} = 28\text{ V}, I_O = 1.0\text{ mA to }1.0\text{ A}$	3.0 mV 0.06%
Output Ripple	$V_{in} = 28\text{ V}, I_O = 1.0\text{ A}$	65 mV pp P.A.R.D.
Short Circuit Current	$V_{in} = 28\text{ V}, R_L = 0.1\ \Omega$	1.6 A
Efficiency	$V_{in} = 28\text{ V}, I_O = 1.0\text{ A}$	71%

L1 - 3.5 mH @ 0.3 A
 T1 - Primary: 20T C.T. #28 AWG
 Secondary: 12OT C.T. #36 AWG
 Core: Ferroxcube 1408P-L00-3CB

TL494, NCV494

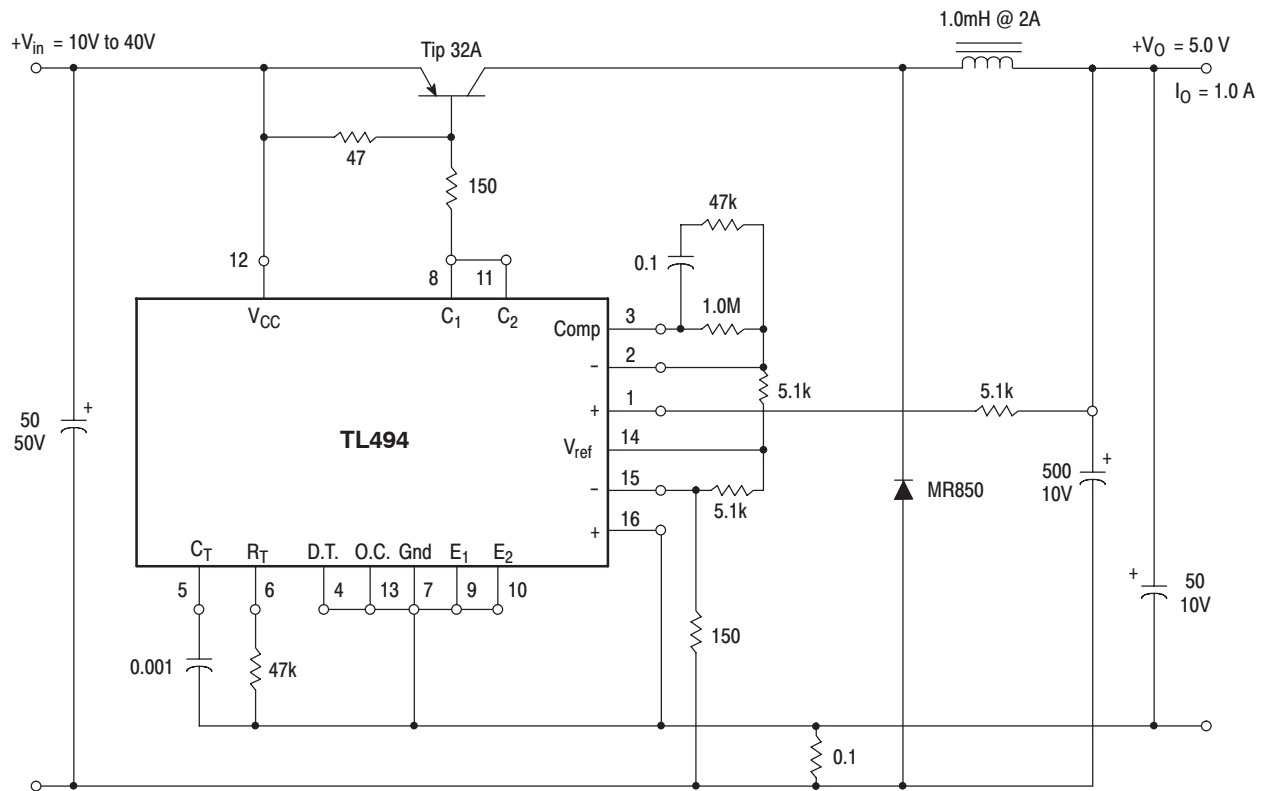

Figure 21. Pulse Width Modulated Step-Down Converter

Test	Conditions	Results
Line Regulation	$V_{in} = 8.0V \text{ to } 40V$	3.0 mV 0.01%
Load Regulation	$V_{in} = 12.6V, I_o = 0.2mA \text{ to } 200mA$	5.0 mV 0.02%
Output Ripple	$V_{in} = 12.6V, I_o = 200mA$	40 mV pp P.A.R.D.
Short Circuit Current	$V_{in} = 12.6V, R_L = 0.1\Omega$	250 mA
Efficiency	$V_{in} = 12.6V, I_o = 200mA$	72%