

DO NOT SCALE FROM THIS PRINT

EMF-1XX-XX-XX-D

No OF POSITIONS  
-05 THRU -50  
(PER ROW)

LEAD STYLE  
-01 EDGE MOUNT (.031")  
\*-02: EDGE MOUNT (.062)

BODY SPECIFICATION  
-D: DOUBLE  
(USE SFM-XX-D-EM-XX)

PLATING SPECIFICATION  
-F: 3μ" SELECTIVE GOLD IN CONTACT AREA, MATTE TIN ON TAIL.  
-L: 10μ" SELECTIVE GOLD IN CONTACT AREA, MATTE TIN ON TAIL.  
-S: 30μ" SELECTIVE GOLD IN CONTACT AREA, MATTE TIN ON TAIL.  
-T: MATTE TIN ON CONTACT AND TAIL.  
-FM: 3μ" SELECTIVE GOLD IN CONTACT AREA, MATTE TIN ON TAIL.  
-LM: 10μ" SELECTIVE GOLD IN CONTACT AREA, MATTE TIN ON TAIL.  
-SM: 30μ" SELECTIVE GOLD IN CONTACT AREA, MATTE TIN ON TAIL.

\* =NOT RELEASED FOR PRODUCTION

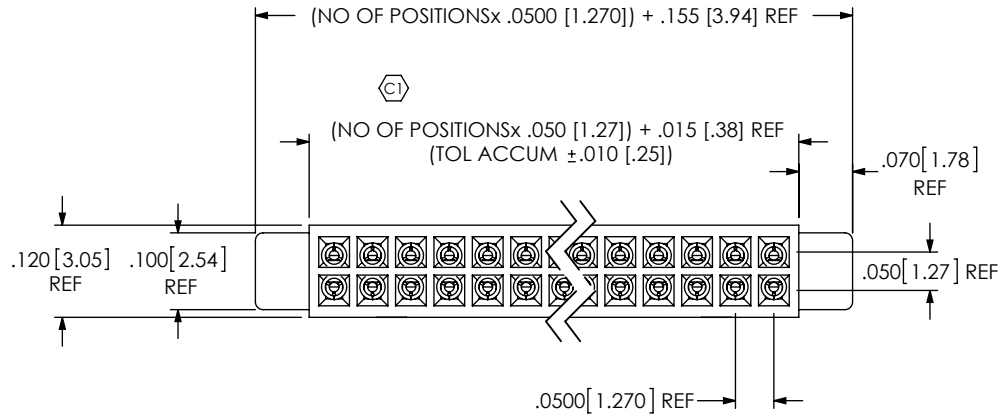
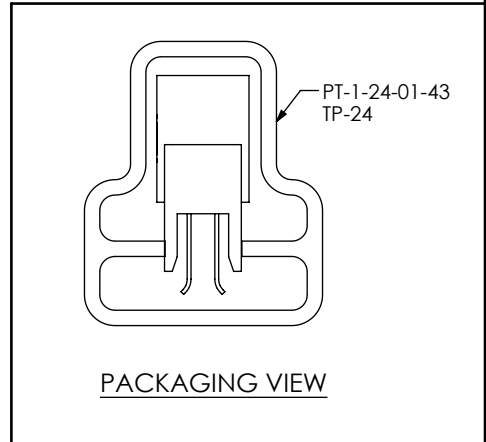
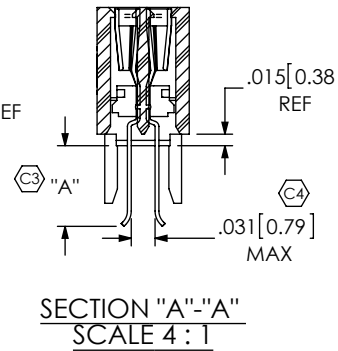
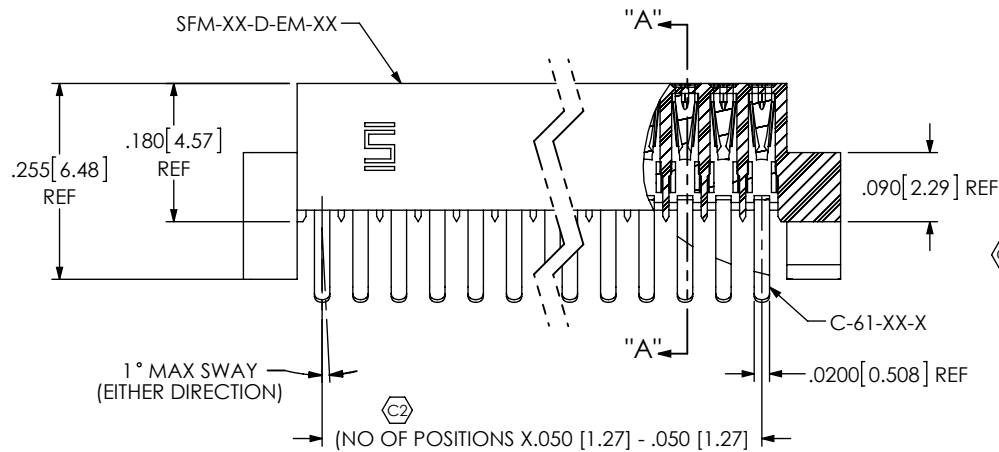

TABLE 4

LEAD STYLE	BODY	CONTACT	"A"
-01	SFM-XX-D-EM-01	C-61-06-X	.126 [3.20]
*-02	SFM-XX-D-EM-02	C-61-08-X	.105 [2.67]



NOTES:

1. Ⓢ REPRESENTS A CRITICAL DIMENSION.
2. MINIMUM PUSHOUT FORCE: .5 LB
3. ALL POSITIONS TO BE PACKAGED IN TUBES.

UNLESS OTHERWISE SPECIFIED, DIMENSIONS ARE IN INCHES.

TOLERANCES ARE:

DECIMALS ANGLES  
.XX: ±.01 [.3] 2°  
.XXX: ±.005 [.13]  
.XXXX: ±.0020 [.051]

PROPRIETARY NOTE

THIS DOCUMENT CONTAINS INFORMATION CONFIDENTIAL AND PROPRIETARY TO SAMTEC, INC. AND SHALL NOT BE REPRODUCED OR TRANSFERRED TO OTHER DOCUMENTS OR DISCLOSED TO OTHERS OR USED FOR ANY PURPOSE OTHER THAN THAT WHICH IT WAS OBTAINED WITHOUT THE EXPRESSED WRITTEN CONSENT OF SAMTEC, INC.



520 PARK EAST BLVD, NEW ALBANY, IN 47150  
PHONE: 812-944-6733 FAX: 812-948-5047  
e-Mail: info@SAMTEC.com code 53322

DO NOT SCALE DRAWING SHEET SCALE: 3:1

INSULATOR: LCP, UL 94 VO, COLOR BLACK

TERMINAL: BeCu, 1/2 HARD, AGE HARDENED

F:\dwg\MISC\Mktg\EMF-1XX-XX-XX-D-MKT.SLDDRW

DESCRIPTION:  
.050 X .050 EDGE MOUNT SOCKET STRIP DUAL ROW ASSEMBLY

DWG. NO. EMF-1XX-XX-XX-D

BY: PURVIS 7-26-96 SHEET 1 OF 1