



# REF-43

## +2.5V LOW-POWER PRECISION VOLTAGE REFERENCE

Precision Monolithics Inc.

### FEATURES

- +2.5 Volt Output .....  $\pm 0.05\%$  Max
- Low Temperature Coefficient ..... 10ppm/°C Max
- Excellent Regulation
  - Load Regulation ..... 20ppm/mA Max
  - Line Regulation ..... 2ppm/V Max
- Supply Current ..... 450 $\mu$ A Max
- Temperature Voltage Output ..... +1.9mV/°C
- Operating Voltage Range ..... +4.5V to +40V
- Extended Industrial Temp Range ..... -40°C to +85°C
- Available in Die Form

### ORDERING INFORMATION <sup>†</sup>

TCV <sub>o</sub>	TO-99	PACKAGE			OPERATING TEMPERATURE RANGE
		CERDIP 8-PIN	PLASTIC 8-PIN	LCC 20-CONTACT	
10	REF43BJ*	REF43BZ*	-	REF43BRC/883*	ML
10	REF43FJ	REF43FZ	-	-	XIND
25	REF43GJ	REF43GZ	REF43GP	-	XIND
25	-	-	REF43GS	-	XIND

\* For devices processed in total compliance to MIL-STD-883, add /883 after part number. Consult factory for 883 data sheet.

<sup>†</sup> Burn-in is available on commercial and industrial temperature range parts in CerDIP, plastic DIP, and TO-can packages. For ordering information, see 1990/91 Data Book, Section 2.

### GENERAL DESCRIPTION

The REF-43 is a low-power precision reference providing a stable +2.5V output independent of variations in supply voltage, load conditions or ambient temperature. It is suitable as a reference level for 8, 10 and 12-bit data acquisition systems, or wherever a stable, known voltage is required.

### SIMPLIFIED SCHEMATIC

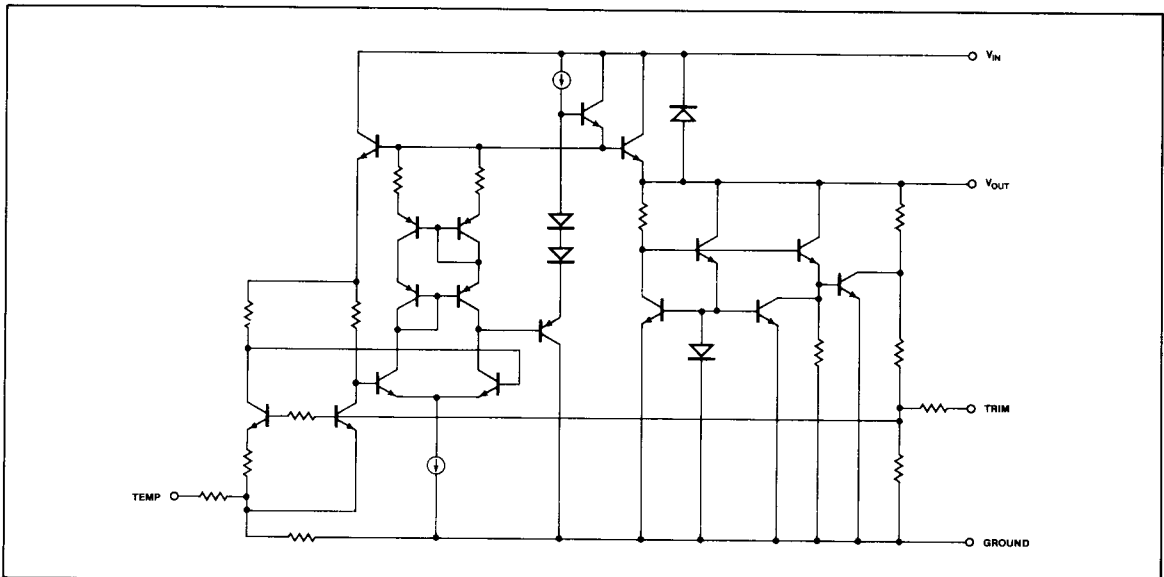

Tight output tolerances and low thermal drift are assured by zener-zap trimming of both output voltage and its temperature coefficient. A unique curvature correction circuit reduces the thermal curvature which is characteristic of many previous bandgap references.

### PIN CONNECTIONS

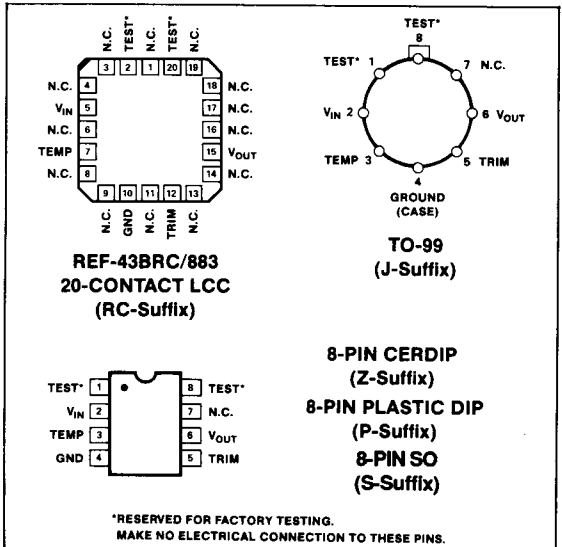

10  
VOLTAGE REFERENCES

The REF-43 may be operated with supply voltages from +4.5V to +40V. The output voltage changes by less than 178 $\mu$ V from one extreme of supply voltage to the other. With only 450 $\mu$ A maximum quiescent current, the REF-43 is ideally suited to applications where power dissipation must be minimized, as in precision battery-powered equipment. The low supply current minimizes drift due to self-heating after power-up.

A temperature output provides a means of determining system ambient temperature. Applications of the REF-43 include A/D and D/A conversion, 4-20mA transmitter/receiver operation, log amplifiers, and power-supply regulators.

For a low-cost 2.5V reference available in small-outline packages consult the REF-03 data sheet.

**ABSOLUTE MAXIMUM RATINGS (Note 1)**

Supply Voltage .....	40V
Internal Power Dissipation .....	500mW
Output Short-Circuit Duration .....	Indefinite

**Operating Temperature Range**

REF-43B (J, Z) .....	-55°C to +125°C
REF-43F (J, Z) .....	-40°C to +85°C
REF-43G (J, Z, P, S) .....	-40°C to +85°C
Storage Temperature Range .....	-65°C to +175°C
Junction Temperature Range .....	-65°C to +175°C
Lead Temperature (Soldering, 10 sec) .....	300°C

PACKAGE TYPE	$\theta_{JA}$ (Note 2)	$\theta_{JC}$	UNITS
TO-99 (J)	150	18	°C/W
8-Pin Hermetic DIP (Z)	148	16	°C/W
8-Pin Plastic DIP (P)	103	43	°C/W
20-Contact LCC (RC)	98	38	°C/W
8-Pin SO (S)	158	43	°C/W

**NOTES:**

1. Absolute maximum ratings apply to both DICE and packaged parts, unless otherwise noted.
2.  $\theta_{JA}$  is specified for worst case mounting conditions, i.e.,  $\theta_{JA}$  is specified for device in socket for TO, CerDIP, P-DIP, and LCC packages;  $\theta_{JA}$  is specified for device soldered to printed circuit board for SO package.

**ELECTRICAL CHARACTERISTICS at  $V_{IN} = +5V$ ,  $I_L = 0mA$ ,  $T_A = 25^\circ C$  unless otherwise noted.**

PARAMETER	SYMBOL	CONDITIONS	REF-43B			REF-43F			REF-43G			UNITS
			MIN	TYP	MAX	MIN	TYP	MAX	MIN	TYP	MAX	
Output Voltage Tolerance		No Load	—	0.04	0.1	—	0.02	0.06	—	0.04	0.1	%
Output Voltage	$V_O$	No Load	2.4975	2.5000	2.5025	2.4985	2.5000	2.5015	2.4975	2.5000	2.5025	V
Output Voltage Noise	$e_{nRMS}$	10Hz to 1kHz (Note 1)	—	7	10	—	7	10	—	7	10	$\mu V_{RMS}$
Line Regulation		$V_{IN} = +4.5V$ to +40V	—	0.8	2	—	0.8	2	—	0.8	2	ppm/V
Load Regulation		$I_L = 0mA$ to 10mA	—	14	20	—	14	20	—	14	20	ppm/mA
Quiescent Supply Current	$I_{SY}$	No Load	—	340	450	—	340	450	—	340	450	$\mu A$
Load Current (Sourcing)	$I_L$	(Note 2)	10	20	—	10	20	—	10	20	—	mA
Load Current (Sinking)	$I_S$	(Note 3)	—	-1.2	—	—	-1.2	—	—	-1.2	—	mA
Short-Circuit Output Current	$I_{SC}$	Output Shorted to Ground	—	60	—	—	60	—	—	60	—	mA
Temperature Voltage Output	$V_{TEMP}$		—	567	—	—	567	—	—	567	—	mV
$V_{OUT}$ Adjust Range			—	$\pm 95$	—	—	$\pm 95$	—	—	$\pm 95$	—	mV
Long-Term Output Drift	$\Delta V_O/Time$	(Note 4)	—	1	—	—	1	—	—	1	—	ppm/month

**NOTES:**

1. Guaranteed but not tested.
2. Guaranteed by load regulation test.
3. Output remains within 2.5V  $\pm$  2.5mV.
4. Calculated from accelerated life tests at  $T_A = 150^\circ C$ .  
Activation energy = 0.7eV.

**ELECTRICAL CHARACTERISTICS** at  $V_{IN} = +5V$ ,  $I_L = 0mA$ ,  $-55^{\circ}C \leq T_A \leq 125^{\circ}C$  for the REF-43B and  $-40^{\circ}C \leq T_A \leq +85^{\circ}C$  for the REF-43F/G, unless otherwise noted.

PARAMETER	SYMBOL	CONDITIONS	REF-43B			REF-43F			REF-43G			UNITS
			MIN	TYP	MAX	MIN	TYP	MAX	MIN	TYP	MAX	
Output Voltage Tolerance		No Load	—	0.03	0.5	—	0.02	0.05	—	0.05	0.2	%
Output Voltage	$V_O$	No Load	2.495	2.500	2.505	2.497	2.500	2.503	2.495	2.500	2.505	V
Output Voltage Temperature Coefficient	$TCV_O$	$-55^{\circ}C \leq T_A \leq +125^{\circ}C$ $-40^{\circ}C \leq T_A \leq +85^{\circ}C$ (Note 1)	—	6	10	—	—	—	—	—	—	ppm/ $^{\circ}C$
Line Regulation		$V_{IN} = +4.5V$ to +40V	—	1	3	—	1	3	—	1	3	ppm/V
Load Regulation		$I_L = 0mA$ to 10mA	—	25	40	—	20	35	—	25	40	ppm/mA
Quiescent Supply Current	$I_{SY}$	No Load	—	400	600	—	400	600	—	400	600	$\mu A$
Load Current (Sourcing)	$I_L$	(Note 2)	10	20	—	10	20	—	10	20	—	mA
Temperature Hysteresis of Output Voltage		$\Delta T = \pm 25^{\circ}C$	—	100	—	—	100	—	—	100	—	$\mu V$
Temperature Voltage Output Tempco	$TCV_{TEMP}$		—	1.9	—	—	1.9	—	—	1.9	—	mV/ $^{\circ}C$

**NOTES:**

- Output voltage temperature coefficient is measured by the box method. The tempco is defined as the slope of the diagonal of a box drawn around the output voltage plotted against temperature.  $V_{OUT}$  is measured at  $T_{MIN}$ ,  $25^{\circ}C$  and  $T_{MAX}$  for the applicable temperature range. The lowest of these three readings is subtracted from the highest reading and the resulting difference is divided by  $(T_{MAX} - T_{MIN})$ .
- Guaranteed by Load Regulation test.

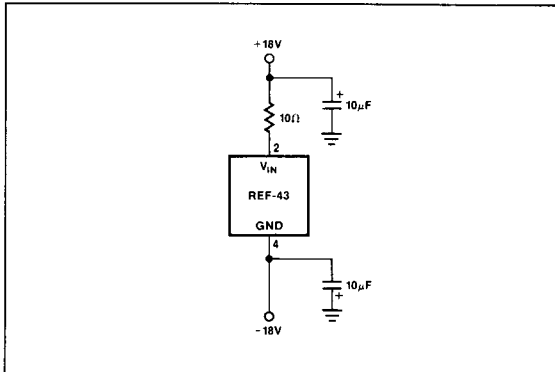
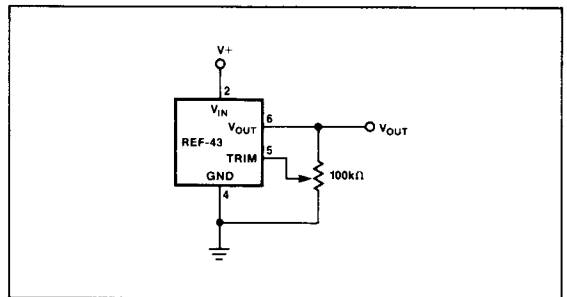
**BURN-IN CIRCUIT**

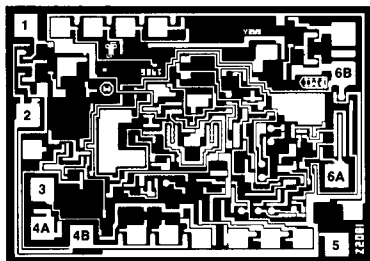
**OUTPUT VOLTAGE TRIM METHOD**

**DICE CHARACTERISTICS**

**DIE SIZE 0.085 × 0.062 inch, 5270 sq. mils**  
(2.16 × 1.57 mm, 3.39 sq. mm)

2.  $V_{IN}$
3. TEMPERATURE OUT
- 4A. GROUND\*
- 4B. GROUND\*
5. TRIM
- 6A.  $V_{OUT}$  FORCE†
- 6B.  $V_{OUT}$  SENSE†

\*PADS 4A AND 4B MUST BOTH BE BONDED TO GROUND.  
† $V_{OUT}$  FORCE AND SENSE ARE TYPICALLY BONDED TOGETHER AT THE LOAD.

**For additional DICE ordering information, refer to 1990/91 Data Book, Section 2.**

**WAFER TEST LIMITS** at  $V_S = +5V$ ,  $T_j = 25^\circ C$ , unless otherwise noted.

PARAMETER	SYMBOL	CONDITIONS	REF-43N	
			LIMIT	UNITS
Output Voltage Tolerance		No Load (Note 1)	2.500 ± 0.005	V MAX
			0.2	% MAX
Line Regulation		$V_{IN} = +4.5V$ to $+40V$	2	ppm MAX
Load Regulation		$I_L = 0mA$ to $10mA$	20	ppm MAX
Quiescent Supply Current	$I_{SV}$	No Load	450	μA MAX
Load Current (Sourcing)	$I_L$	(Note 2)	10	mA MIN

**NOTES:**

1. Final output trims are not performed on standard product dice. These trims are typically performed after packaging. Precision Monolithics Inc. assumes no responsibility for improper trimming by the customer. Contact factory for trim methods.
2. Guaranteed by load regulation test. Electrical tests are performed at wafer probe to the limits shown. Due to variations in assembly methods and normal yield loss, yield after packaging is not guaranteed for standard product dice. Consult factory to negotiate specifications based on dice lot qualification through sample lot assembly and testing.

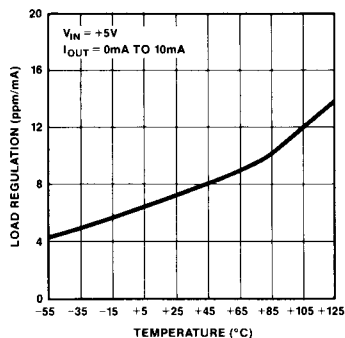
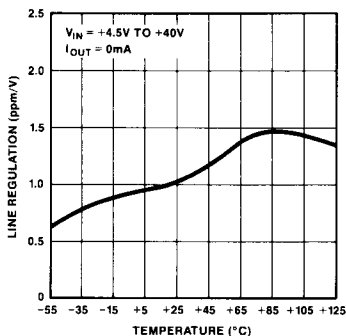
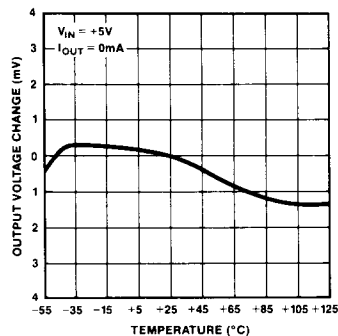
**TYPICAL PERFORMANCE CHARACTERISTICS**
**LOAD REGULATION vs TEMPERATURE**

**LINE REGULATION vs TEMPERATURE**

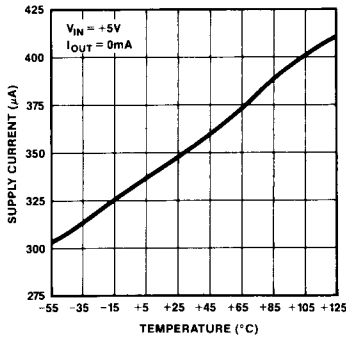
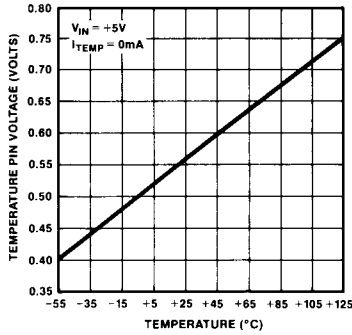
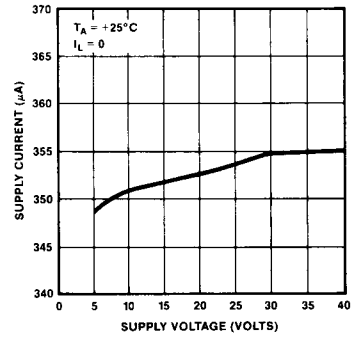
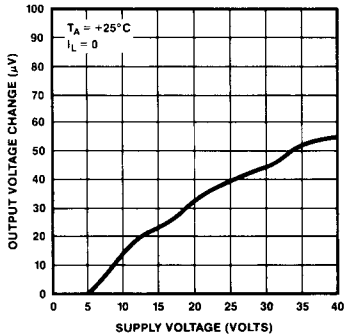
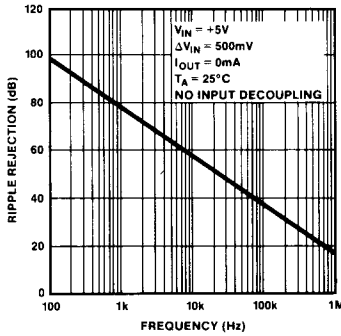
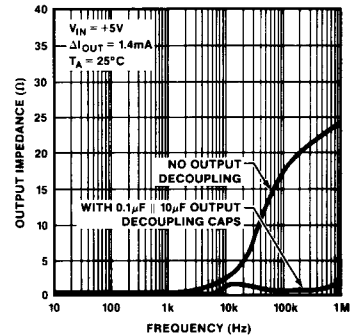
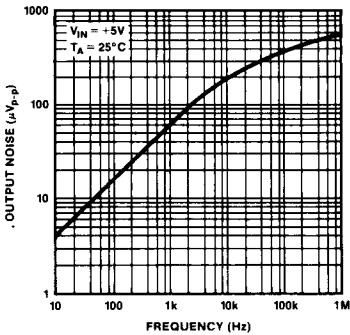
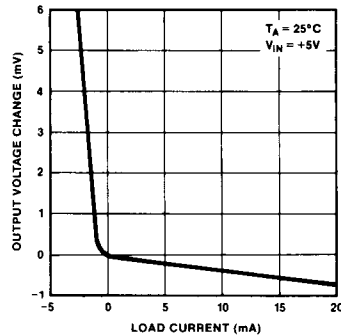
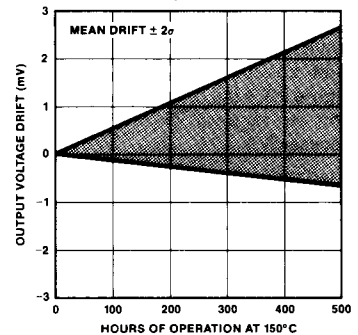
**OUTPUT VOLTAGE CHANGE vs TEMPERATURE**

## TYPICAL PERFORMANCE CHARACTERISTICS

**SUPPLY CURRENT vs TEMPERATURE**

**TEMPERATURE PIN VOLTAGE vs TEMPERATURE**

**SUPPLY CURRENT vs SUPPLY VOLTAGE**

**OUTPUT VOLTAGE CHANGE vs SUPPLY VOLTAGE**

**RIPPLE REJECTION vs FREQUENCY**

**OUTPUT IMPEDANCE vs FREQUENCY**

**WIDEBAND OUTPUT NOISE vs BANDWIDTH (0.1Hz TO FREQUENCY INDICATED)**

**OUTPUT VOLTAGE CHANGE vs LOAD CURRENT**

**BURN-IN DRIFT AT TA = 150°C**

10

VOLTAGE REFERENCES

### APPLICATIONS INFORMATION

The REF-43 provides a stable +2.5V output voltage with minimal dependence on load current, line voltage or temperature. This voltage is typically used to set an absolute reference point in data conversion circuits, or in analog circuits such as log amps, 4-20mA transmitters and power supplies. The REF-43 is of particular value in systems requiring a high-precision reference using a single +5V supply rail, or where power dissipation must be minimized.

Because an onboard operational amplifier is used to amplify the basic bandgap cell voltage to 2.5V, supply decoupling is critical to the transient performance of a voltage reference. The supply line should be bypassed with a 10 $\mu$ F tantalum capacitor in parallel with a 0.01 $\mu$ F to 0.1 $\mu$ F ceramic capacitor for best results. For less critical conditions, a single 0.1 $\mu$ F capacitor is adequate.

**FIGURE 1:** Basic Connections

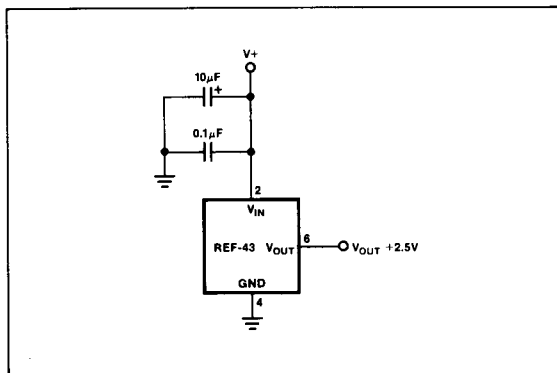

Output decoupling is not generally required or recommended, except to achieve the lowest possible high-frequency output impedance when loads are being switched in and out quickly. As was the case with supply decoupling, best results will be achieved with a 10 $\mu$ F tantalum capacitor in parallel with a 0.01 $\mu$ F to 0.1 $\mu$ F ceramic capacitor. Recommended high-frequency decoupling is shown in Figure 2A, while the transient response of the REF-43 to a sudden 2mA load is shown in Figures 2B and 2C. As can be seen from Figure 2B, if the reference is given 10 $\mu$ s to settle after application or removal of the load, no output decoupling is necessary.

Load regulation is a measure of the DC output impedance of the reference. For the REF-43, this value is specified at 20ppm/mA Max, which is equivalent to only 50 milliohms of output impedance. It is obvious that to truly realize this performance level, wiring resistances from the reference to the rest of the system must be kept as low as is practical.

The REF-43 is capable of delivering at least 10mA to a load. To maintain its precision operation, loads should be kept within the 10mA specification. High-speed testing requires that load regulation is measured on a pulse basis, therefore

**FIGURE 2A:** Recommended Decoupling for High-Frequency Pulse Response

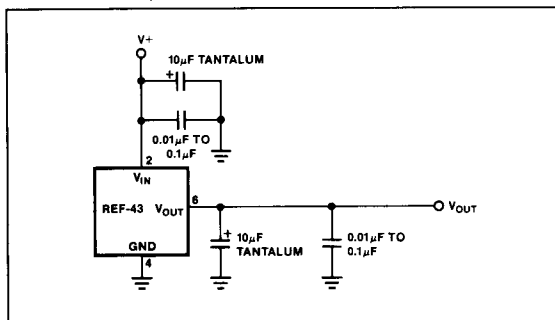

**FIGURE 2B:** Pulse Response with No Output Decoupling

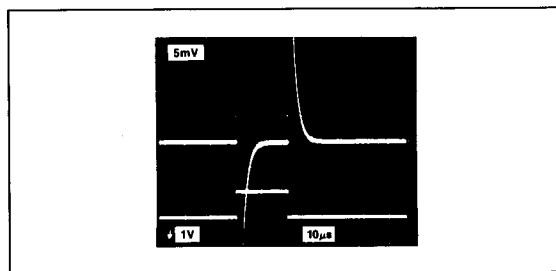

**FIGURE 2C:** Pulse Response with Output Decoupling

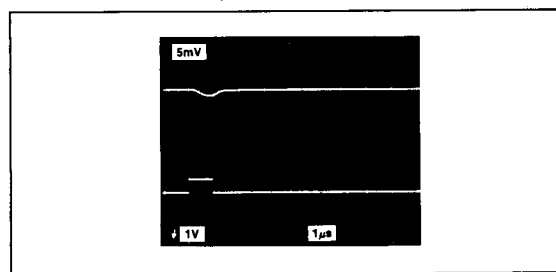

when calculating the output voltage tolerance within a system, the effects of current delivered to the load must be accounted for both as load regulation and as a temperature increase due to power dissipated within the IC. In AC systems, the RMS power dissipation should be used. Thermal effects can be significant since a REF-43 delivering 10mA with an input voltage of 40V must dissipate almost 400mW of power. In the TO-99 package, 400mW of power corresponds to a die temperature increase of 60°C above ambient.

Die temperature is calculated by  $T_j = (P_D \times \theta_{JA}) + T_A$ , where  $P_D$  is the sum of the power dissipation due to quiescent current and current delivered to the load,  $P_D = (I_{SY} \times V_S) + (I_{LOAD} \times (V_S - 2.5V))$ . The  $\theta_{JA}$  for different packages in a PC board surrounded by free air are listed below.

PACKAGE TYPE	TYP $\theta_{JA} (^{\circ}\text{C}/\text{W})$
TO-99	150
CERDIP	80
PLASTIC	80
LCC	110

An additional source of error is due to temperature gradients across the package leads, resulting in thermocouple effects. Temperature gradients will be generated when the IC is required to dissipate large amounts of power. Even at low power levels, thermocouple effects may appear as low frequency noise due to air currents across the leads. A significant improvement in low-frequency noise will be found by encasing the reference and any metal junctions such as solder joints (which form thermocouples) along the reference path in a light insulating foam or other enclosure to reduce turbulence. Thermocouple effects can easily add over  $10\mu\text{V}_{p-p}$  of low-frequency noise.

The temperature output of the REF-43 provides an output voltage which is proportional to the die temperature. When the REF-43 is operating at constant load current, this is a good indication of system temperature. The nominal output voltage at  $25^{\circ}\text{C}$  is 567mV, and the slope is typically  $1.9\text{mV}/^{\circ}\text{C} (\pm 0.2\text{mV}/^{\circ}\text{C})$ . The TEMP output is affected by the internal trimming done for output voltage tolerance, and will vary between units. If the temperature pin 3 is connected to external circuitry, it should be buffered by an op amp. Current into or out of pin 3 will change the temperature coefficient and curvature of the output voltage, while capacitance at the pin can create instabilities within the reference amplifier.

**GENERATING A -2.5V REFERENCE**

Often, there is a requirement for a negative reference voltage. The simplest method of generating a -2.5V reference with the REF-43 is to connect an op amp in a gain of -1 to the output, as shown in Figure 3. This provides both positive and negative 2.5V references. Figure 4 shows another method of obtaining a negative reference, in which the current-output

FIGURE 3:  $\pm 2.5\text{V}$  Reference

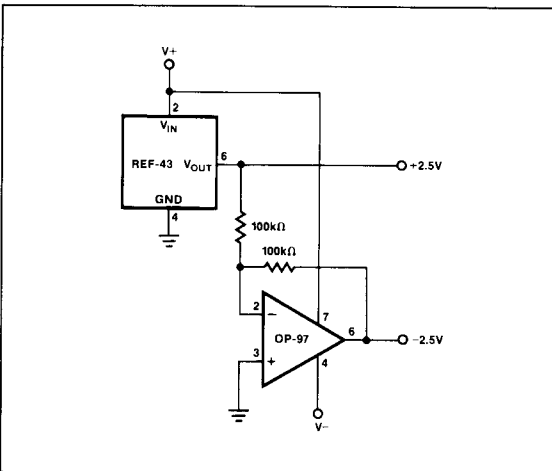
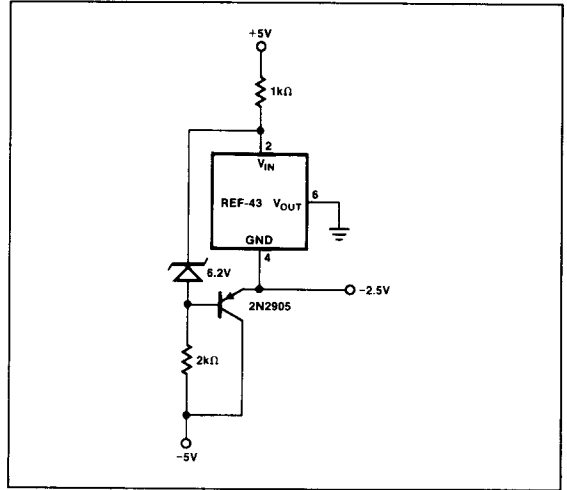

FIGURE 4: -2.5V Reference



element is a PNP transistor, with the REF-43 in a servo loop to ensure that the output remains 2.5V below ground.

**BOOST TRANSISTOR PROVIDES HIGH OUTPUT CURRENT**

When applications require more than 10mA current delivery, an external boost transistor may be added to the REF-43 to pass the required current without dissipating excessive power within the IC. The maximum current output to the system is bounded only by the capabilities of the boost transistor. This technique is shown in Figure 5 with and without current limiting. Current limiting may be used to prevent damage to the boost transistor. In Figure 5b, the limit occurs when the voltage dropped across R2 exceeds one  $V_{BE}$  (0.6V). The current limit is sensitive to the variations of the diodes' forward drop and the PNP's  $V_{BE}$  with temperature, and will decrease with increasing temperature.

FIGURE 5: Output Current Boost

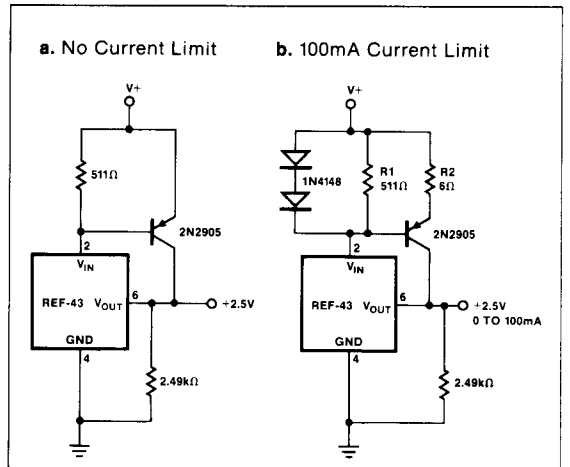

**LOW-POWER CMOS DAC REFERENCE**

The REF-43 makes an excellent reference for use with CMOS and bipolar DACs. Figure 6 shows the REF-43 connected to the DAC-8012, a 12-bit parallel loading CMOS DAC with memory. With an OP-43 output amplifier for fast settling, the circuit requires less than 3mA when driven from TTL gates, and less than 2mA when driven from CMOS gates. In situations not requiring the higher speed of the OP-43, enhanced linearity and some savings in power dissipation can be realized using an OP-97 for the output amplifier.

**PRECISION CURRENT SOURCE**

Current sources are often required in analog processing and computational circuits. The circuit of Figure 7 shows a high-output-impedance current source capable of single-supply operation. Performance is optimal at current levels below 1mA, since output voltage changes directly affect the power dissipated within the REF-43.

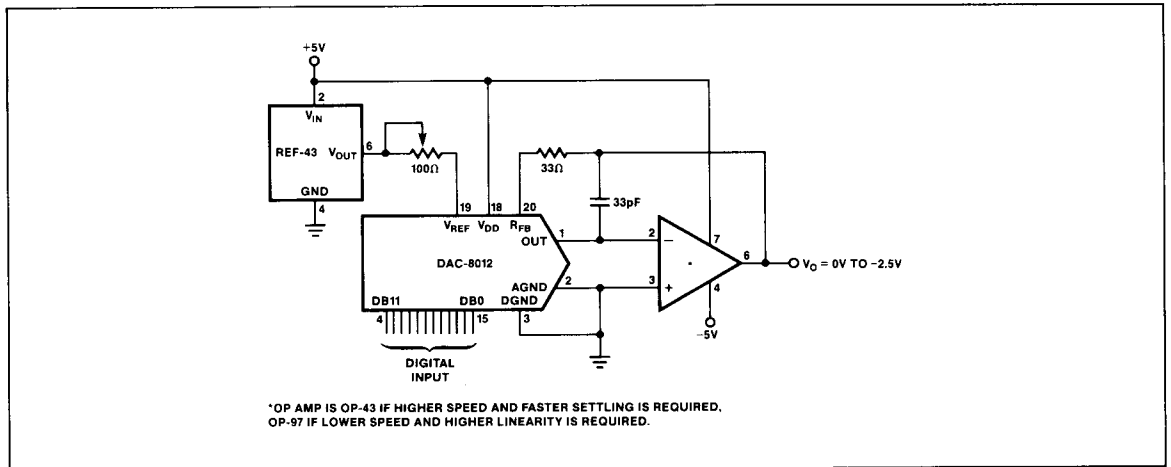
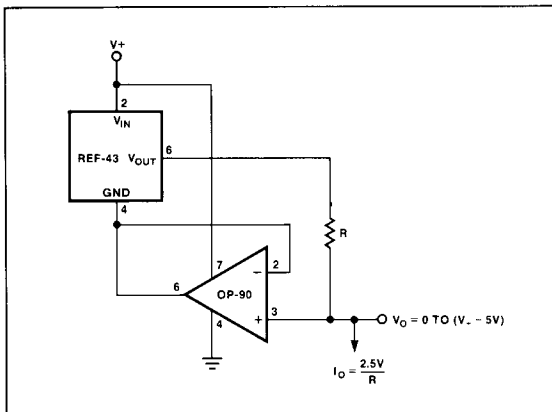
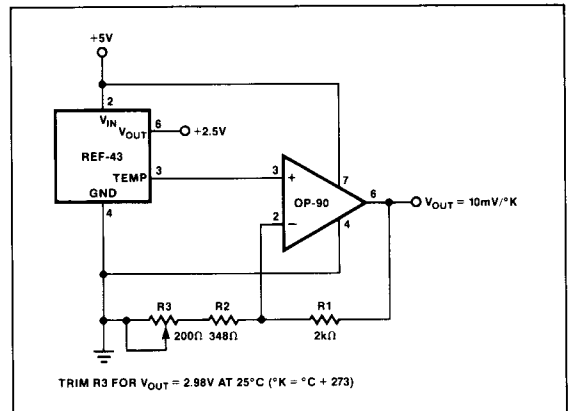
**FIGURE 6: CMOS DAC Reference**

**FIGURE 7: Precision Current Source**

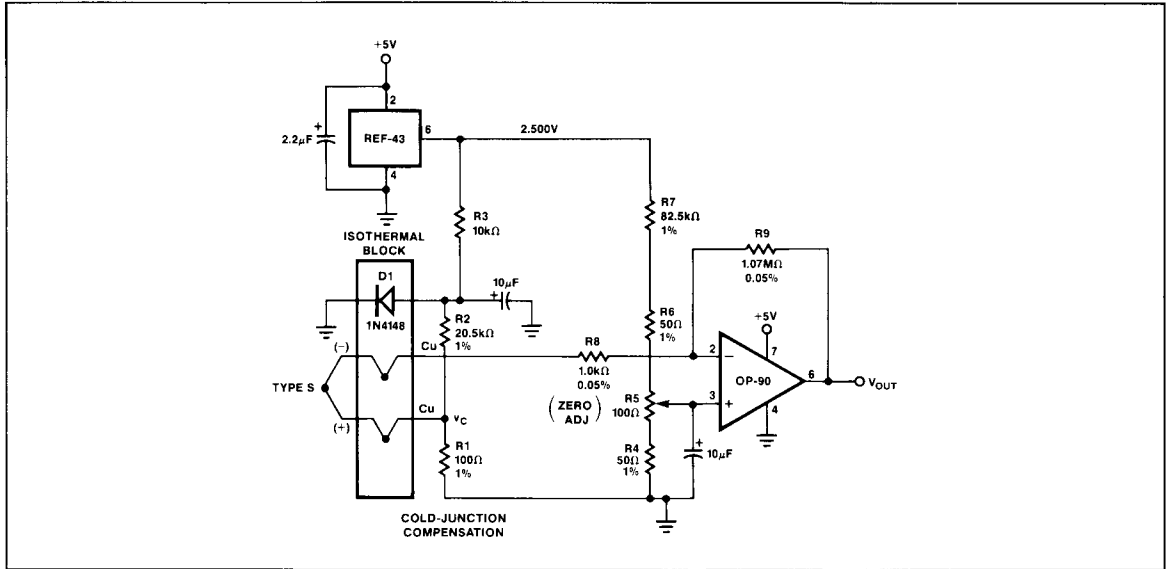
**FIGURE 8: Single-Supply Kelvin-Output Thermometer**



**FIGURE 9:** Thermocouple Amplifier with Cold-Junction Compensation

### TEMPERATURE MEASUREMENT

Using the REF-43's TEMP output, a Kelvin-output thermometer that operates off a single +5V supply can be built as shown in Figure 8. Since the output of the REF-43's TEMP pin is theoretically zero at 0°K, trimming R3 adjusts both the slope and zero point. In actuality, the  $\pm 40\text{mV}$  zero point found by extrapolating the TEMP voltage vs. actual temperature to zero will create a small error. A 4-20mA temperature transmitter is described on page 10 which uses two trims to eliminate this inaccuracy.

For wider temperature ranges than semiconductors can withstand, thermocouples are commonly used. Depending upon the type used, a thermocouple can measure temperatures over 1000°C. Thermocouples require a reference junction, at a known temperature, usually 0°C. Since it is not generally convenient to have an ice bath, electronic methods of simulating this junction have been developed, called cold-junction compensation. In Figure 9, diode D1 is mounted isothermally to the termination of the thermocouple, and along with R1 and R2 provides the cold-junction compensation required for accurate measurement. Using an OP-90 as the amplifier, the circuit will operate off a single +5V supply and is capable of measuring temperatures from 0°C to +400°C. If negative temperatures must be measured, dual supplies must be used to allow the op amp to swing negative. In cases where the electronics are subject to temperature fluctuations, an OP-77 is recommended for its extremely low  $\text{TCV}_{\text{OS}}$ .

Calibration of the thermocouple amplifier is done after a 15 minute warm-up time using R5. A copper wire short is placed across the thermocouple terminating junctions, simulating a 0°C condition. R5 is then adjusted for a 0.00V output. The short is then removed and the amplifier is ready for use. Note that special care must be used in calibration when this circuit is operated single-supply, as the output of the OP-90 will swing to within 500µV of ground, but not below ground. Thus R5 must be trimmed to the point where the output just barely reaches its swing limit.

By changing the appropriate resistor values, the amplifier may be used with type S, J or K thermocouples. In all cases, the output has been scaled with R9 to provide an output of 10mV/°C.

SEEBECK					
TYPE	COEFFICIENT, $\alpha$	R1	R2	R7	R9
K	39.2µV/°C	110Ω	5.76kΩ	102kΩ	269kΩ
J	50.2µV/°C	100Ω	4.02kΩ	80.6kΩ	200kΩ
S	10.3µV/°C	100Ω	20.5kΩ	392kΩ	1.07MΩ

### TWO-WIRE 4-20mA TRANSMITTERS

4-20mA current loops are used in noisy environments for many types of remote data acquisition. With a two-wire loop, the sensing circuitry can be powered with the same lines used for signal transmission.

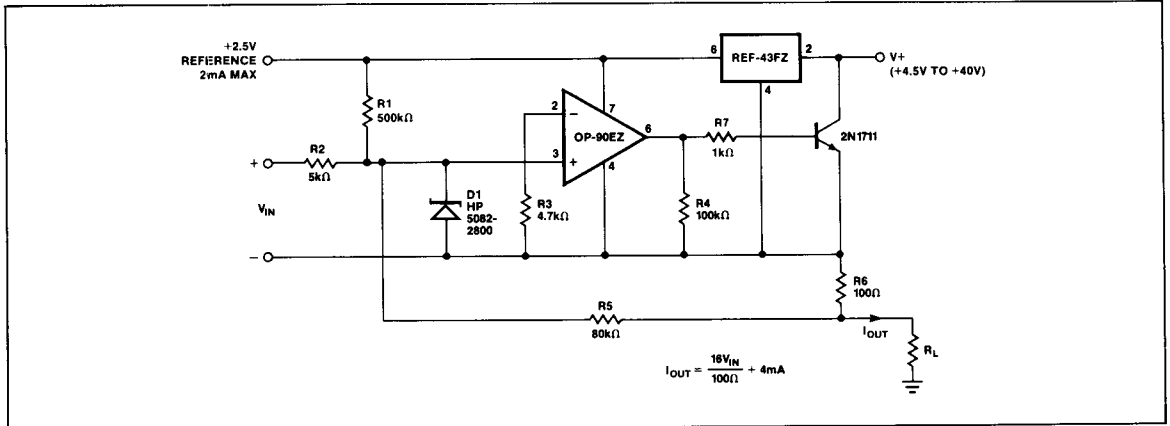
**FIGURE 10:** Two Wire 4-20mA Transmitter

The current transmitter of Figure 10 provides an output of 4mA to 20mA that is linearly proportional to the input voltage. Linearity of the transmitter exceeds 0.004% and line rejection is below measurement limits.

Biasing for the current transmitter is provided by the REF-43FZ. The OP-90EZ regulates the output current to satisfy the current summation at the noninverting node:

$$I_{OUT} = \frac{1}{R_6} \left( \frac{V_{IN} R_5}{R_2} + \frac{2.5V R_5}{R_1} \right)$$

For the values shown in Figure 10,

$$I_{OUT} = \left( \frac{16}{100} \right) V_{IN} + 4mA$$

giving a full-scale output of 20mA with a 100mV input. Adjustment of R2 will provide an offset trim and adjustment of R1 will provide a gain trim. These trims do not interact since the noninverting input of the OP-90 is at virtual ground. The Schottky diode, D1, prevents input voltage spikes from pulling the noninverting input more than 300mV below the inverting input. Without the diode, such spikes could cause phase reversal of the OP-90 and possible latch-up of the transmitter. Compliance of this circuit is from 4.5V to 40V. The voltage reference output can provide up to 2mA for transducer excitation.

The OP-90 is also available in dual and quad versions. Using an OP-490, three of the amplifiers can be used to implement a full instrumentation amplifier for signal conditioning before delivery to the 4-20mA transmitter. All four OP-90s require less than 80μA supply current, and thus have virtually no impact on the current-budget of the 4-20mA loop.

A simple temperature to 4-20mA transmitter is shown in Figure 11. After calibration, the transmitter is accurate to within 1°C over the -50°C to +150°C temperature range. The transmitter operates from +6V to +40V with supply rejection better than

3ppm/V. An OP-90 is used to buffer the TEMP pin, while the second OP-90 regulates the output current to satisfy the current summation at its noninverting input.

$$I_{OUT} = \frac{V_{TEMP} (R_6 + R_7)}{R_2 R_{10}} - V_{SET} \left( \frac{R_2 + R_6 + R_7}{R_2 R_{10}} \right)$$

The change in output current with temperature is the derivative of the transfer function:

$$\frac{\Delta I_{OUT}}{\Delta T} = \frac{\Delta V_{TEMP}}{\Delta T} \left( \frac{R_6 + R_7}{R_2 R_{10}} \right)$$

From the formulas, it can be seen that if the gain trim is adjusted before the final offset trim, the two trims are not interactive, which greatly simplifies the calibration procedure.

To calibrate the transmitter, begin by placing the REF-43 in an ice water (0°C) bath. If necessary, adjust the offset trim, R5, so that the output current is above 4mA.

Record the output current. Next, place the REF-02 in a boiling water (100°C) bath. Adjust the gain trim, R6, so that the change in the output current reflects the desired mA/°C ratio described as follows:

$$\text{Output Ratio} = \frac{\Delta I_{FS}}{\Delta T_{OPERATING}} = \frac{16mA}{\Delta T_{OPERATING}}$$

As an example, assume the transmitter is to operate over the -50°C to +150°C temperature range:

$$\text{Output Ratio} = \frac{16mA}{(150^\circ C - 50^\circ C)} = \frac{16mA}{(200^\circ C)} = 0.08mA/^\circ C$$

If  $I_{OUT}$  in the ice water bath equaled 6.3mA, then in the boiling water bath:

$$I_{OUT(100^\circ C)} = I_{OUT(0^\circ C)} + 100^\circ C (0.08mA/^\circ C) \\ = 6.3mA + 8mA = 14.3mA$$

With the REF-43 in the boiling water bath, the gain trim, R6, in this example should be adjusted so I<sub>OUT</sub> equals 14.3mA.

Once the gain trim has been completed, the offset trim can be made. Remember, that adjusting the offset trim will not affect the gain.

The offset trim can be set at any known temperature by adjusting R5 until the output current equals:

$$I_{OUT} = \left( \frac{\Delta I_{FS}}{\Delta T_{OPERATING}} \right) (T_{AMBIENT} - T_{MIN}) + 4mA$$

Using the previous example and assuming the REF-43 is at 20°C:

$$I_{OUT} = \left( \frac{16mA}{200^{\circ}C} \right) [20^{\circ}C - (-50^{\circ}C)] + 4mA = 9.6mA$$

Table 1 shows the values of R6 and R7 required for various temperature ranges.

TABLE 1

TEMP RANGE	R6 (FIXED)	R7 (TRIMPOT)
0°C to +70°C	10k	5k
-40°C to +85°C	6k	3k
-50°C to +150°C	3k	2k

FIGURE 11: Temperature to 4-20mA Transmitter

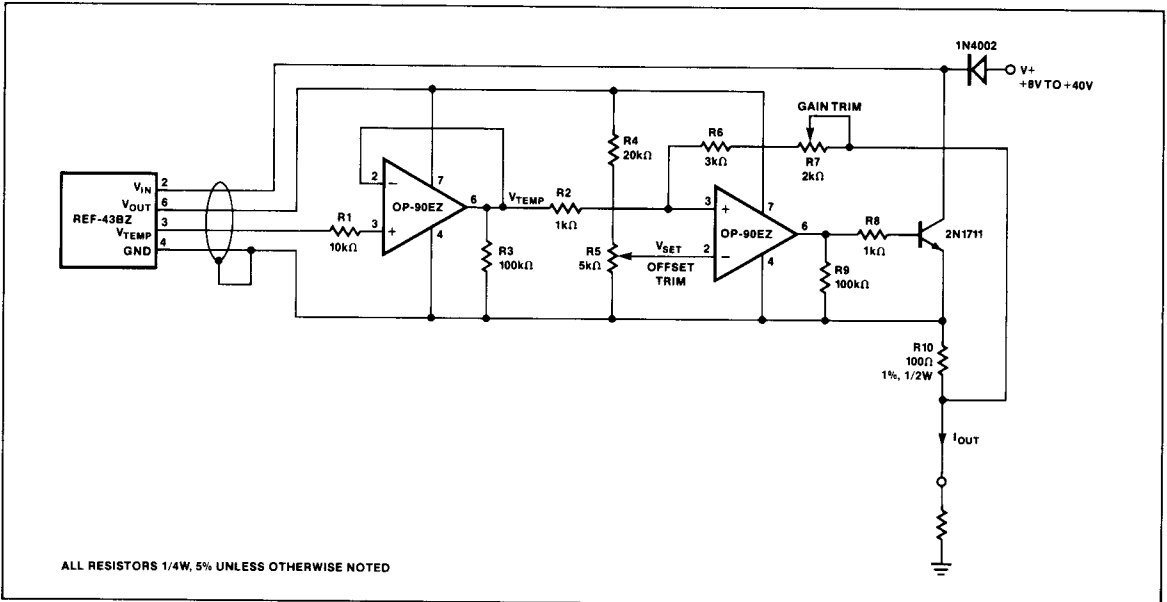

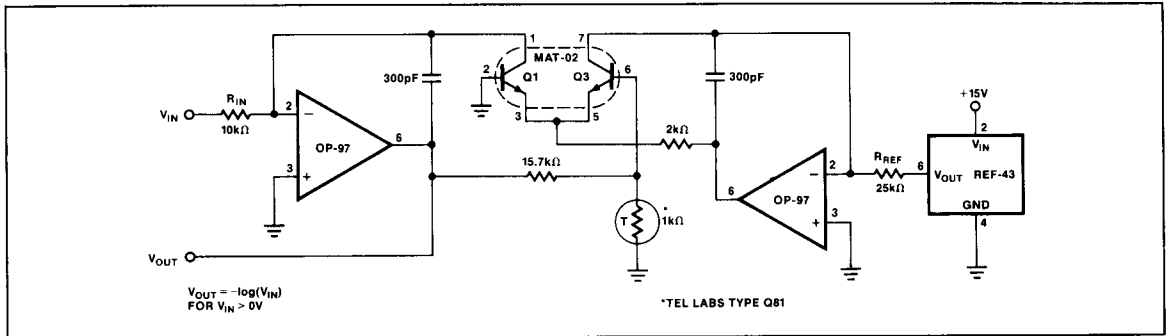
**FIGURE 12: Low Power Logarithmic Amplifier**

**LOW-POWER LOGARITHMIC AMPLIFIER**

A logarithmic amplifier accurate over more than 4 decades is shown in Figure 12. This circuit requires less than 2mA of current when the input is at 1V (0V output). The output voltage is given by  $V_{OUT} = \log(V_{REF}/R_{REF}) - \log(V_{IN}/R_{IN})$ , thus the zero point may be adjusted by  $R_{REF}$  and the input scaling by  $R_{IN}$ .