

Features

- High-speed: $t_{PD} = 1.8\text{ns}$ typical into 50pF @ $5\text{V } V_{CC}$
- Unbuffered Output
- Broad operating range: $V_{CC} = 1.65\text{V}$ to 5.5V
- Balanced output drive: $\pm 16\text{mA}$ at $4.5\text{V } V_{CC}$
- Package: 5-pin space saving SOT23(T) and SC70(C)

Description

The PI74STX1GU04 is a single unbuffered inverter that operates over the 1.65V to $5.5\text{V } V_{CC}$ operating range. The internal design of a single stage inverter makes this device especially suitable for crystal oscillation or analog applications.

Pericom's PI74STX series of products are produced using the Company's advanced submicron technology.

Pinout

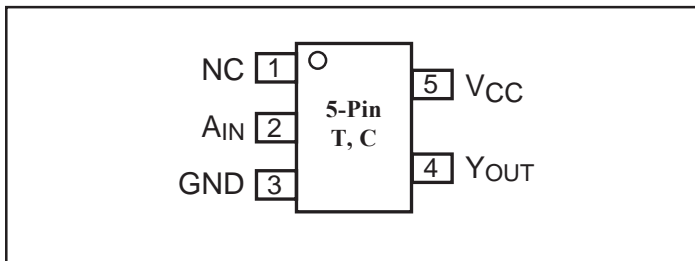

Block Diagram

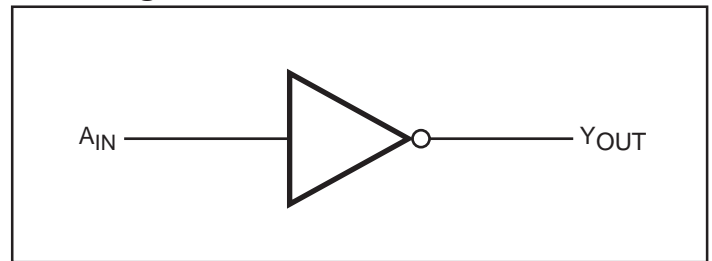

Pin Description

Pin Names	Description
A_{IN}	Input
Y_{OUT}	Output
NC	No Connect

Recommended Operating Conditions⁽¹⁾

Parameter	Condition	Min.	Max.	Units
Supply Voltage (V_{CC})		1.65	5.5	V
Input Voltage (V_{IN})		0	5.5	
Output Voltage (V_{OUT})		0	V_{CC}	
Operating Temperature		-40	85	°C
Input Rise and Fall Time (t_r, t_f)	$V_{CC} = 1.8\text{V}, 2.5\text{V} \pm 0.2\text{V}$	0	20	ns/V
	$V_{CC} = 3.3\text{V} \pm 0.3\text{V}$	0	10	
	$V_{CC} = 5.0\text{V} \pm 0.5\text{V}$	0	5	

Function Table

Inputs	Output
A_{IN}	Y_{OUT}
L	H
H	L

Note:

H =HIGH Logic Level
L =LOW Logic Level

Note:

1. Unused inputs must be held HIGH or LOW. They may not float.

Absolute Maximum Ratings

Supply Voltage (V_{CC})	-0.5V to +6V	DC V_{CC}/GND Current (I_{CC}/I_{GND})	±50mA
DC Input Voltage (V_{IN})	-0.5V to +6V	Storage Temperature (T_{STG})	-65°C to +150°C
DC Output Voltage (V_{OUT})	-0.5V to $V_{CC} + 0.5V$	Junction Lead Temperature (IOS)	200°C
DC Input Diode Current (I_{IK})	-50mA to 20mA	Power Dissipation SOT23	200mW
DC Output Diode Current (I_{OK})	-50mA to 20mA	SC70	150mW
DC Output Current (I_{OUT})	±50mA		

Note:

Absolute maximum ratings are DC values beyond which the device may be damaged or have its useful life impaired. The datasheet specifications should be met, without exception, to ensure that the system design is reliable over its power supply, temperature, and output/input loading variables. Pericom does not recommend operation outside datasheet specifications.

DC Electrical Characteristics (Over supply voltage and operating temperature ranges, unless otherwise specified)

Symbol	Parameters	V_{CC} (V)	Conditions		$T_A = +25^\circ C$			$T_A = -40$ to $+85^\circ C$		Units
					Min.	Typ.	Max.	Min.	Max.	
V_{IH}	HIGH level Input Voltage	1.8 - 2.7 3.0 - 5.5			0.85 V_{CC} 0.8 V_{CC}			0.85 V_{CC} 0.8 V_{CC}		
V_{IL}	LOW level Input Voltage	1.8 - 2.7 3.0 - 5.5					0.15 V_{CC} 0.2 V_{CC}		0.15 V_{CC} 0.2 V_{CC}	
V_{OH}	HIGH level Output Voltage	1.65	$V_{IN} = V_{IL}$	$I_{OH} = -100\mu A$	1.55	1.65		1.55		V
		1.8			1.6	1.8		1.6		
		2.3			2.1	2.3		2.1		
		3.0			2.7	3.0		2.7		
		4.5			4.0	4.4		4.0		
		1.65	$I_{OH} = -4mA$	1.29	1.48		1.29			
		2.3		1.9	2.20		1.9			
		3.0		2.4	2.83		2.4			
		3.0		2.3	2.74		2.3			
		4.5		3.8	4.25		3.8			
V_{OL}	LOW level Output Voltage	1.65	$V_{IN} = V_{IH}$	$I_{OL} = 100\mu A$		0.0	0.1		0.1	
		1.8			0.0	0.2		0.2		
		2.3			0.0	0.2		0.2		
		3.0			0.0	0.3		0.3		
		4.5			0.0	0.5		0.5		
		1.65	$I_{OL} = 4mA$	0.13	0.24		0.24			
		2.3		0.09	0.3		0.3			
		3.0		0.16	0.4		0.4			
		3.0		0.24	0.55		0.55			
		4.5		0.26	0.55		0.55			
I_{IN}	Input Leakage Current	0 to 5.5	$V_{IN} = 5.5V$ or GND				±1		±10	µA
I_{CC}	Quiescent Supply Current	1.65 - 5.5	$V_{IN} = 5.5V$ or GND				2.0		20	
I_{CCPEAK}	Peak Supply Current in Analog Operation	1.8 2.5 3.3 5.0	$V_{OUT} = \text{Open}$ $V_{IN} = \text{Adjust for Peak } I_{CC}$ Current			0.7 4.8 14 38				mA

AC Electrical Characteristics

Symbol	Parameter	V _{CC} (V)	Conditions	T _A = +25°C			T _A = -40°C to +85°C		Units	Fig. No.
				Min.	Typ.	Max.	Min.	Max.		
t _{PLH} , t _{PHL}	Propagation Delay	1.8 ±0.15	C _L = 15pF, R _L = 1M ohm	0.7		6.0	0.7	6.9	ns	1
		2.5 ±0.2		0.5		4.0	0.5	4.6		
		3.3 ±0.3		0.5		2.5	0.5	2.9		3
		5.0 ±0.5		0.5		2.1	0.5	2.4		
t _{PLH} , t _{PHL}	Propagation Delay	3.3 ±0.3	C _L = 50pF, R _L = 500 ohms	0.5		3.7	0.5	4.3	pF	1
		5.0 ±0.5		0.5		3.0	0.5	3.5		
C _{IN}	Input Capacitance	0			5.5					
C _{PD}	Power Dissipation Capacitance ⁽³⁾	3.3			6.1					2
		5.0			9.2					

Notes:

3. C_{PD} is defined as the value of the internal equivalent capacitance which is derived from dynamic operating current consumption (I_{CCD}) at no output loading and operating at 50% duty cycle (see Figure 2). C_{PD} is related to I_{CCD} dynamic operating current by the expression: I_{CCD} = (C_{PD})(V_{CC})(f_{IN}) + (I_{CC} static).

AC Loading and Waveforms

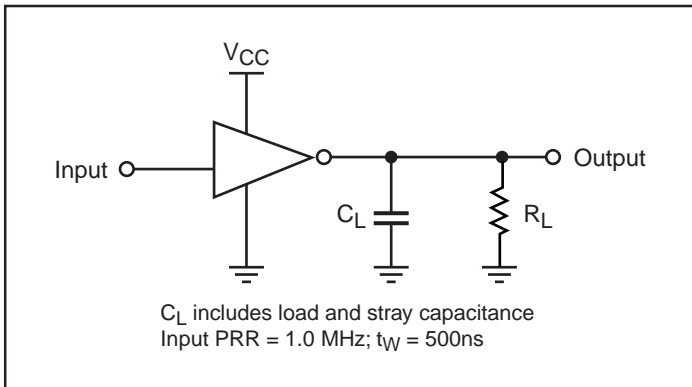

Figure 1. AC Test Circuit

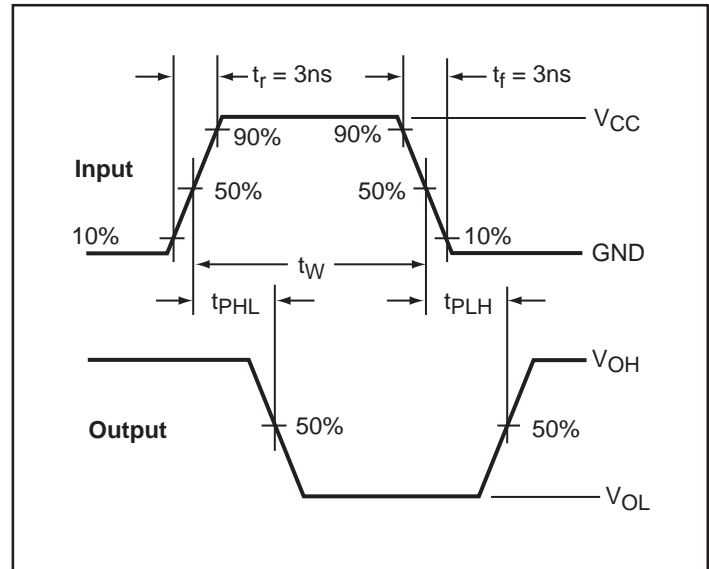

Figure 3. AC Waveforms

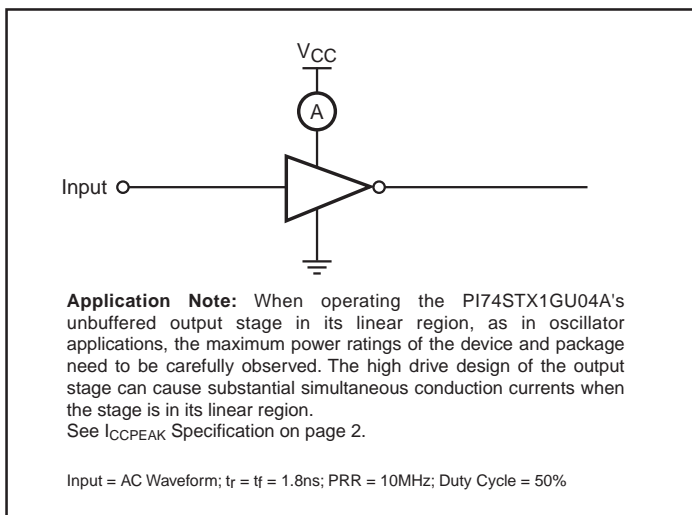
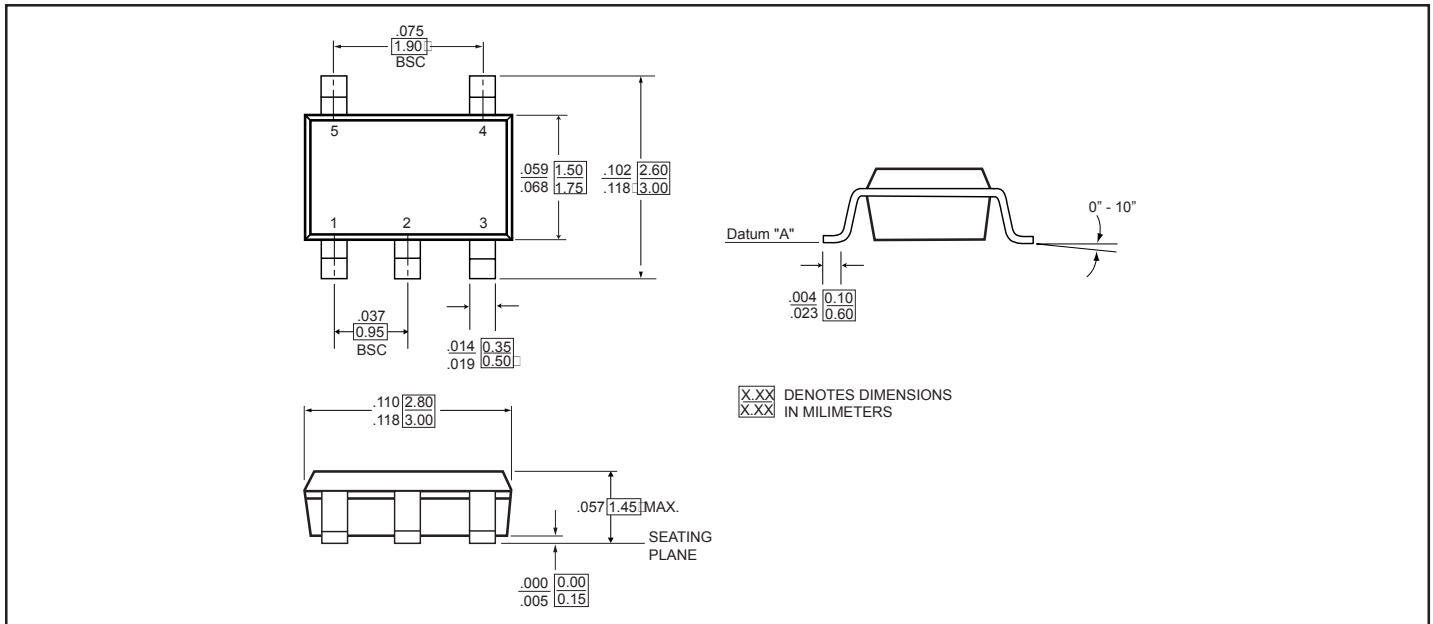
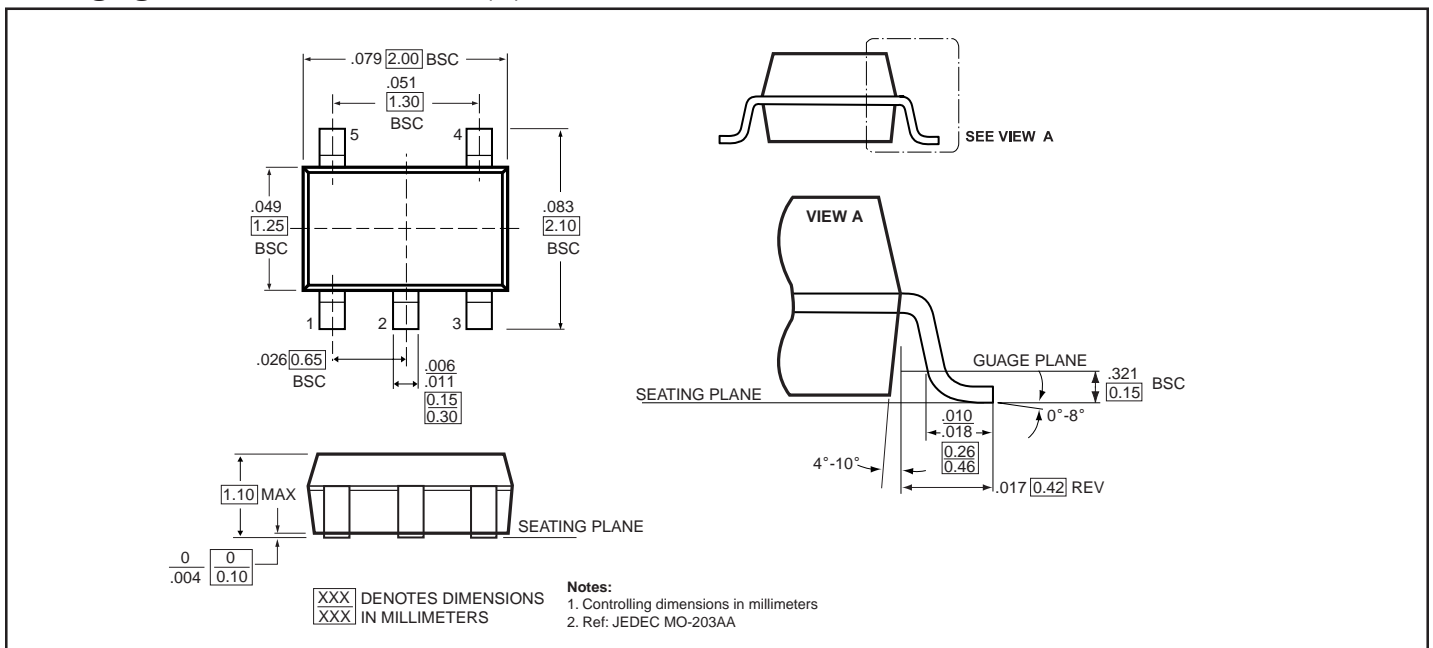

Figure 2. I_{CCD} Test Circuit

Packaging Mechanical: 5-Pin SOT23 (T)



Packaging Mechanical: 5-Pin SC70 (C)



Thermal Characteristics can be found on the web: <http://www.pericom.com/packaging/mechanicals.php>

Ordering Information

Part	Pin-Package	Top Marking	Operating Range
PI74STX1GU04ATX	5-Pin - SOT23	M4A	-40°C to 85°C
PI74STX1GU04ACX	5-Pin - SC70	M4A	-40°C to 85°C

Pericom Semiconductor Corporation

2380 Bering Drive • San Jose, CA 95131 • 1-800-435-2336 • Fax (408) 435-1100 • <http://www.pericom.com>