

DATA SHEET

74ABT16244A

74ABTH16244A

16-bit buffer/line driver (3-State)

Product specification
Supersedes data of 1996 Aug 15
IC23 Data Handbook

1997 May 01

16-bit buffer/line driver (3-State)

74ABT16244A 74ABTH16244A

FEATURES

- 16-bit bus interface
- Multiple V_{CC} and GND pins minimize switching noise
- Power-up 3-State
- 3-State buffers
- Output capability: +64 mA/-32mA
- Live insertion/extraction permitted
- Latch-up protection exceeds 500mA per JEDEC Std 17
- ESD protection exceeds 2000 V per MIL STD 883 Method 3015 and 200 V per Machine Model
- 74ABTH16244A incorporates bus hold data inputs which eliminate the need for external pull up resistors to hold unused inputs

DESCRIPTION

The 74ABT16244A high-performance BiCMOS device combines low static and dynamic power dissipation with high speed and high output drive.

The 74ABT16244A device is a 16-bit buffer that is ideal for driving bus lines. The device features four Output Enables (1 \overline{OE} , 2 \overline{OE} , 3 \overline{OE} , 4 \overline{OE}), each controlling four of the 3-State outputs.

Two options are available, 74ABT16244A which does not have the bus hold feature and 74ABTH16244A which incorporates the bus hold feature.

QUICK REFERENCE DATA

SYMBOL	PARAMETER	CONDITIONS T _{amb} = 25°C; GND = 0V	TYPICAL	UNIT
t _{PLH} t _{PHL}	Propagation delay nAx to nYx	C _L = 50pF; V _{CC} = 5V	1.7 2.1	ns
C _{IN}	Input capacitance	V _I = 0V or V _{CC}	4	pF
C _{OUT}	Output capacitance	V _O = 0V or V _{CC} ; 3-State	7	pF
I _{CCZ}	Quiescent supply current	Outputs disabled; V _{CC} = 5.5V	450	μA
I _{CCL}		Outputs low; V _{CC} = 5.5V	10	mA

ORDERING INFORMATION

PACKAGES	TEMPERATURE RANGE	OUTSIDE NORTH AMERICA	NORTH AMERICA	DWG NUMBER
48-Pin Plastic SSOP Type III	-40°C to +85°C	74ABT16244A DL	BT16244A DL	SOT370-1
48-Pin Plastic TSSOP Type II	-40°C to +85°C	74ABT16244A DGG	BT16244A DGG	SOT362-1
48-Pin Plastic SSOP Type III	-40°C to +85°C	74ABTH16244A DL	BTH16244A DL	SOT370-1
48-Pin Plastic TSSOP Type II	-40°C to +85°C	74ABTH16244A DGG	BTH16244A DGG	SOT362-1

LOGIC SYMBOL

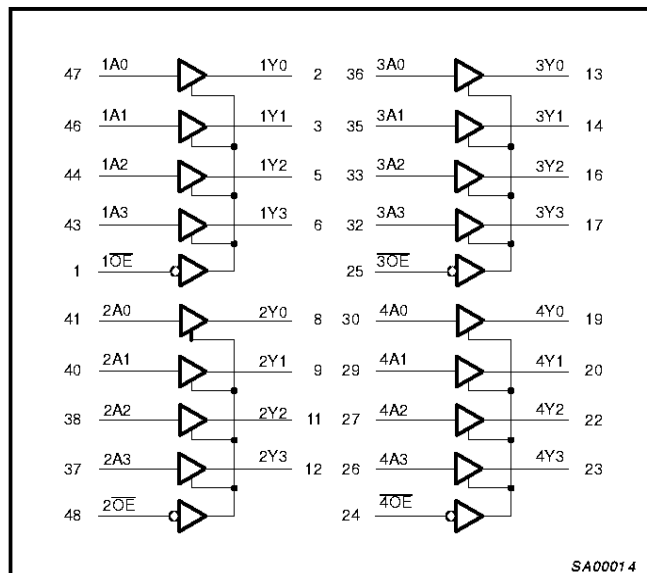

16-bit buffer/line driver (3-State)

74ABT16244A
74ABTH16244A

LOGIC SYMBOL (IEEE/IEC)

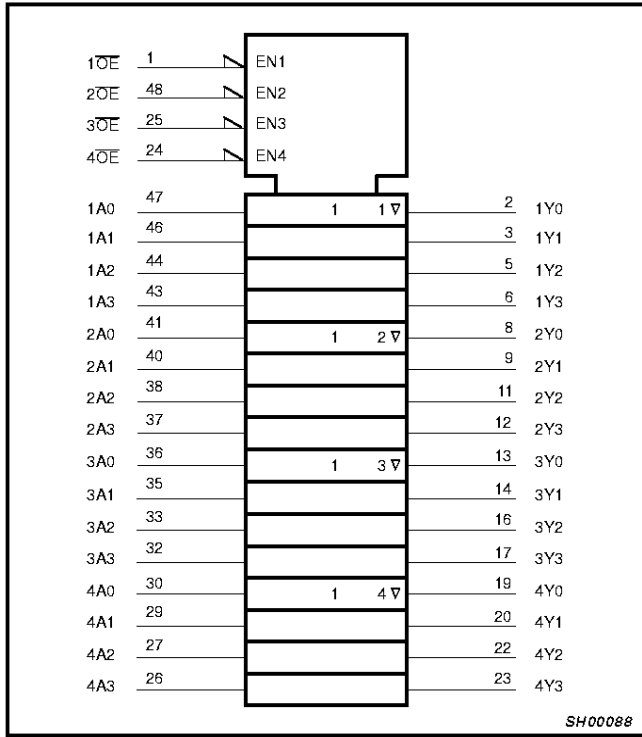

PIN DESCRIPTION

PIN NUMBER	SYMBOL	NAME AND FUNCTION
47, 46, 44, 43, 41, 40, 38, 37, 36, 35, 33, 32, 30, 29, 27, 26	1A0 – 1A3, 2A0 – 2A3, 3A0 – 3A3, 4A0 – 4A3	Data inputs
2, 3, 5, 6, 8, 9, 11, 12, 13, 14, 16, 17, 19, 20, 22, 23	1Y0 – 1Y3, 2Y0 – 2Y3, 3Y0 – 3Y3, 4Y0 – 4Y3	Data outputs
1, 48, 25, 24	1OE, 2OE, 3OE, 4OE	Output enables
4, 10, 15, 21, 28, 34, 39, 45	GND	Ground (0V)
7, 18, 31, 42	V _{CC}	Positive supply voltage

FUNCTION TABLE

INPUTS		OUTPUTS
nOE	nAx	nYx
L	L	L
L	H	H
H	X	Z

H = High voltage level
L = Low voltage level
X = Don't care
Z = High impedance "off" state

PIN CONFIGURATION

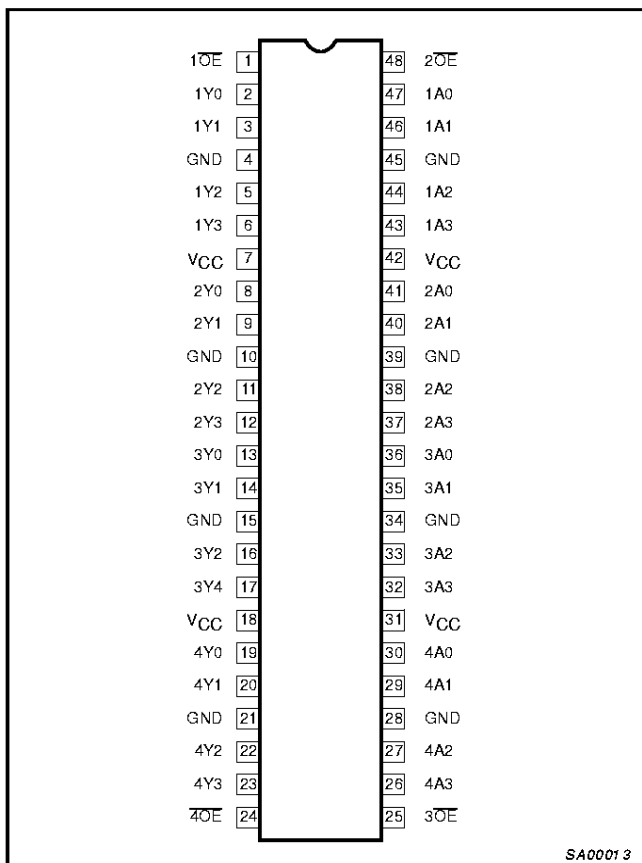

16-bit buffer/line driver (3-State)

74ABT16244A
74ABTH16244A**ABSOLUTE MAXIMUM RATINGS^{1, 2}**

SYMBOL	PARAMETER	CONDITIONS	RATING	UNIT
V _{CC}	DC supply voltage		-0.5 to +7.0	V
I _{IK}	DC input diode current	V _I < 0	-18	mA
V _I	DC input voltage ³		-1.2 to +7.0	V
I _{OK}	DC output diode current	V _O < 0	-50	mA
V _{OUT}	DC output voltage ³	output in Off or High state	-0.5 to +5.5	V
I _{OUT}	DC output current	output in Low state	128	mA
		output in High state	-64	
T _{stg}	Storage temperature range		-65 to 150	°C

NOTES:

- Stresses beyond those listed may cause permanent damage to the device. These are stress ratings only and functional operation of the device at these or any other conditions beyond those indicated under "recommended operating conditions" is not implied. Exposure to absolute-maximum-rated conditions for extended periods may affect device reliability.
- The performance capability of a high-performance integrated circuit in conjunction with its thermal environment can create junction temperatures which are detrimental to reliability. The maximum junction temperature of this integrated circuit should not exceed 150°C.
- The input and output voltage ratings may be exceeded if the input and output current ratings are observed.

RECOMMENDED OPERATING CONDITIONS

SYMBOL	PARAMETER	LIMITS		UNIT
		MIN	MAX	
V _{CC}	DC supply voltage	4.5	5.5	V
V _I	Input voltage	0	V _{CC}	V
V _{IH}	High-level input voltage	2.0		V
V _{IL}	Low-level input voltage		0.8	V
I _{OH}	High-level output current		-32	mA
I _{OL}	Low-level output current		64	mA
Δt/Δv	Input transition rise or fall rate	0	10	ns/V
T _{amb}	Operating free-air temperature range	-40	+85	°C

16-bit buffer/line driver (3-State)

74ABT16244A
74ABTH16244A

DC ELECTRICAL CHARACTERISTICS

SYMBOL	PARAMETER	TEST CONDITIONS	LIMITS					UNIT
			T _{amb} = +25°C			T _{amb} = -40°C to +85°C		
			Min	Typ	Max	Min	Max	
V _{IK}	Input clamp voltage	V _{CC} = 4.5V; I _{IK} = -18mA		-0.9	-1.2		-1.2	V
V _{OH}	High-level output voltage	V _{CC} = 4.5V; I _{OH} = -3mA; V _I = V _{IL} or V _{IH}	2.5	2.9		2.5		V
		V _{CC} = 5.0V; I _{OH} = -3mA; V _I = V _{IL} or V _{IH}	3.0	3.4		3.0		
		V _{CC} = 4.5V; I _{OH} = -32mA; V _I = V _{IL} or V _{IH}	2.0	2.4		2.0		
V _{OL}	Low-level output voltage	V _{CC} = 4.5V; I _{OL} = 64mA; V _I = V _{IL} or V _{IH}		0.42	0.55		0.55	V
I _I	Input leakage current	V _{CC} = 5.5V; V _I = GND or 5.5V		±0.01	±1.0		±1.0	µA
I _I	Input leakage current 74ABTH16244A	V _{CC} = 5.5V; V _I = V _{CC} or GND		±0.01	±1		±1	µA
		V _{CC} = 5.5V; V _I = V _{CC}		0.01	1		1	
		V _{CC} = 5.5V; V _I = 0		-2	-3		-5	
I _{HOLD}	Bus Hold current A inputs 74ABTH16244A	V _{CC} = 4.5V; V _I = 0.8V	50			50		µA
		V _{CC} = 4.5V; V _I = 2.0V	-75			-75		
I _{OFF}	Power-off leakage current	V _{CC} = 0.0V; V _O or V _I ≤ 4.5V		±5.0	±100		±100	µA
I _{PU} /I _{PD}	Power-up/down 3-State output current	V _{CC} = 2.0V; V _O = 0.5V; V _I = GND or V _{CC} ; V _{OE} = V _{CC}		±5.0	±50		±50	µA
I _{OZH}	3-State output High current	V _{CC} = 5.5V; V _O = 5.5V; V _I = V _{IL} or V _{IH}		0.1	10		10	µA
I _{OZL}	3-State output Low current	V _{CC} = 5.5V; V _O = 0.0V; V _I = V _{IL} or V _{IH}		-0.1	-10		-10	µA
I _{CEX}	Output High leakage current	V _{CC} = 5.5V; V _O = 5.5V; V _I = GND or V _{CC}		5.0	50		50	µA
I _O	Output current ¹	V _{CC} = 5.5V; V _O = 2.5V	-50	-100	-180	-50	-180	mA
I _{CCH}	Quiescent supply current ³	V _{CC} = 5.5V; Outputs High, V _I = GND or V _{CC}		0.45	1.0		1.0	mA
I _{CCL}		V _{CC} = 5.5V; Outputs Low, V _I = GND or V _{CC}		10	19		19	mA
I _{CCZ}		V _{CC} = 5.5V; Outputs 3-State; V _I = GND or V _{CC}		0.45	1.0		1.0	µA
ΔI _{CC}	Additional supply current per input pin ^{2, 3}	Outputs enabled, one data input at 3.4V, other inputs at V _{CC} or GND; V _{CC} = 5.5V		100	250		250	µA
		Outputs disabled, one data input at 3.4V, other inputs at V _{CC} or GND; V _{CC} = 5.5V		100	250		250	
		Control pins, outputs disabled, one enable input at 3.4V, other inputs at V _{CC} or GND; V _{CC} = 5.5V		100	250		250	

NOTES:

- Not more than one output should be tested at a time, and the duration of the test should not exceed one second.
- This is the increase in supply current for each input at 3.4V.
- This data sheet limit may vary among suppliers.

16-bit buffer/line driver (3-State)

74ABT16244A
74ABTH16244A

AC CHARACTERISTICS

GND = 0V; $t_R = t_F = 2.5\text{ns}$; $C_L = 50\text{pF}$, $R_L = 500\Omega$

SYMBOL	PARAMETER	WAVEFORM	LIMITS					UNIT
			$T_{amb} = +25^\circ\text{C}$ $V_{CC} = +5.0\text{V}$			$T_{amb} = -40^\circ\text{C to } +85^\circ\text{C}$ $V_{CC} = +5.0\text{V} \pm 0.5\text{V}$		
			MIN	TYP	MAX	MIN	MAX	
t_{PLH} t_{PHL}	Propagation delay nAx to nYx	1	1.1 1.3	1.7 2.1	2.6 2.9	1.1 1.3	2.8 3.4	ns
t_{PZH} t_{PZL}	Output enable time to High and Low level	2	1.6 2.3	2.7 3.5	3.7 4.0	1.6 2.3	4.5 4.8	ns
t_{PHZ} t_{PLZ}	Output disable time from High and Low level	2	2.0 1.6	3.0 2.4	4.0 3.2	2.0 1.6	4.6 4.1	ns

AC WAVEFORMS

$V_M = 1.5\text{V}$, $V_{IN} = \text{GND to } 3.0\text{V}$

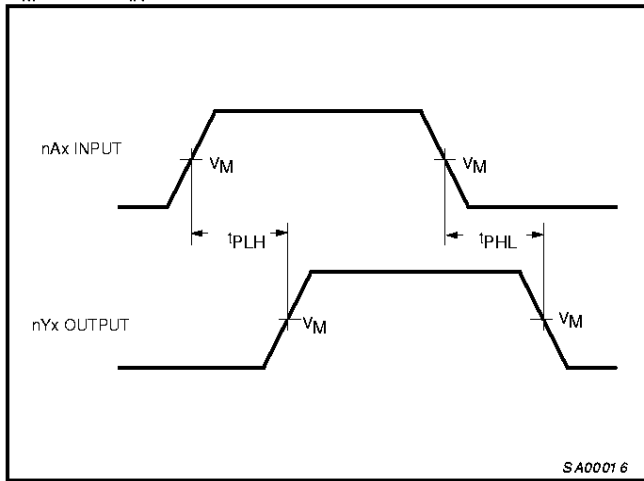

Waveform 1. Waveforms Showing the Input (An) to Output (Yn) Propagation Delays

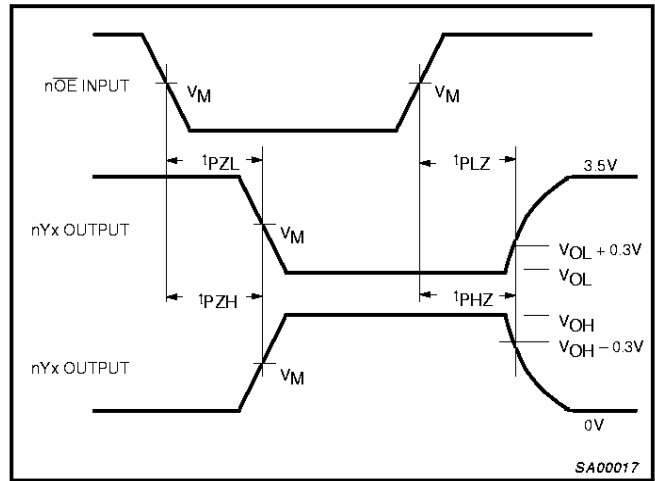

Waveform 2. Waveforms Showing the 3-State Output Enable and Disable Times

16-bit buffer/line driver (3-State)

74ABT16244A
74ABTH16244A

TEST CIRCUIT AND WAVEFORMS

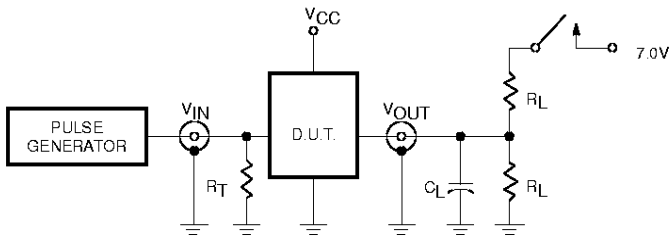

Test Circuit for 3-State Outputs

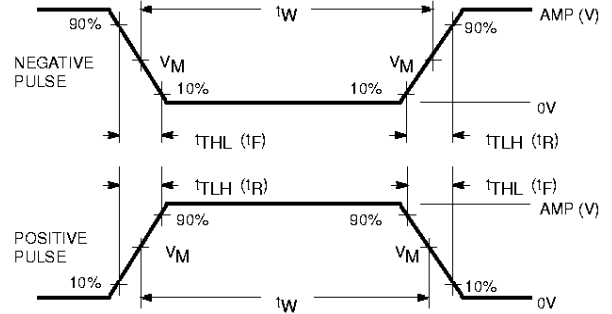

$V_M = 1.5V$
Input Pulse Definition

SWITCH POSITION

TEST	SWITCH
t_{PLZ}	closed
t_{pZL}	closed
All other	open

DEFINITIONS

R_L = Load resistor; see AC CHARACTERISTICS for value.
 C_L = Load capacitance includes jig and probe capacitance; see AC CHARACTERISTICS for value.
 R_T = Termination resistance should be equal to Z_{OUT} of pulse generators.

FAMILY	INPUT PULSE REQUIREMENTS				
	Amplitude	Rep. Rate	t_W	t_R	t_F
74ABT/H16	3.0V	1MHz	500ns	2.5ns	2.5ns

SA00018

16-bit buffer/line driver (3-State)

74ABT16244A
74ABTH16244A

SSOP48: plastic shrink small outline package; 48 leads; body width 7.5 mm

SOT370-1

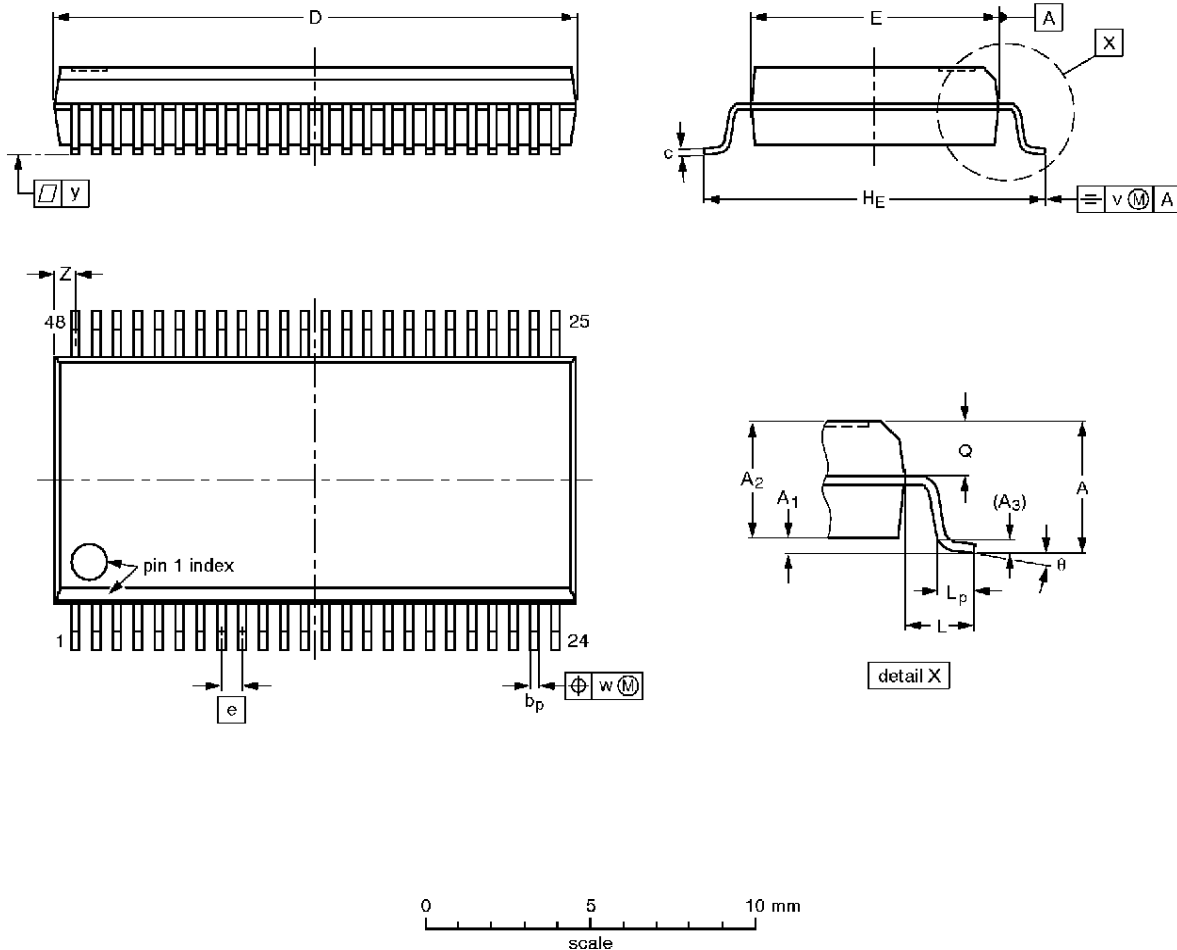

DIMENSIONS (mm are the original dimensions)

UNIT	A max.	A ₁	A ₂	A ₃	b _p	c	D ⁽¹⁾	E ⁽¹⁾	e	H _E	L	L _p	Q	v	w	y	Z ⁽¹⁾	θ
mm	2.8	0.4 0.2	2.35 2.20	0.25	0.3 0.2	0.22 0.13	16.00 15.75	7.6 7.4	0.635	10.4 10.1	1.4	1.0 0.6	1.2 1.0	0.25	0.18	0.1	0.85 0.40	8° 0°

Note

1. Plastic or metal protrusions of 0.25 mm maximum per side are not included.

OUTLINE VERSION	REFERENCES				EUROPEAN PROJECTION	ISSUE DATE
	IEC	JEDEC	EIAJ			
SOT370-1		MO-118AA				93-11-02 95-02-04

16-bit buffer/line driver (3-State)

74ABT16244A 74ABTH16244A

TSSOP48: plastic thin shrink small outline package; 48 leads; body width 6.1 mm

SOT362-1

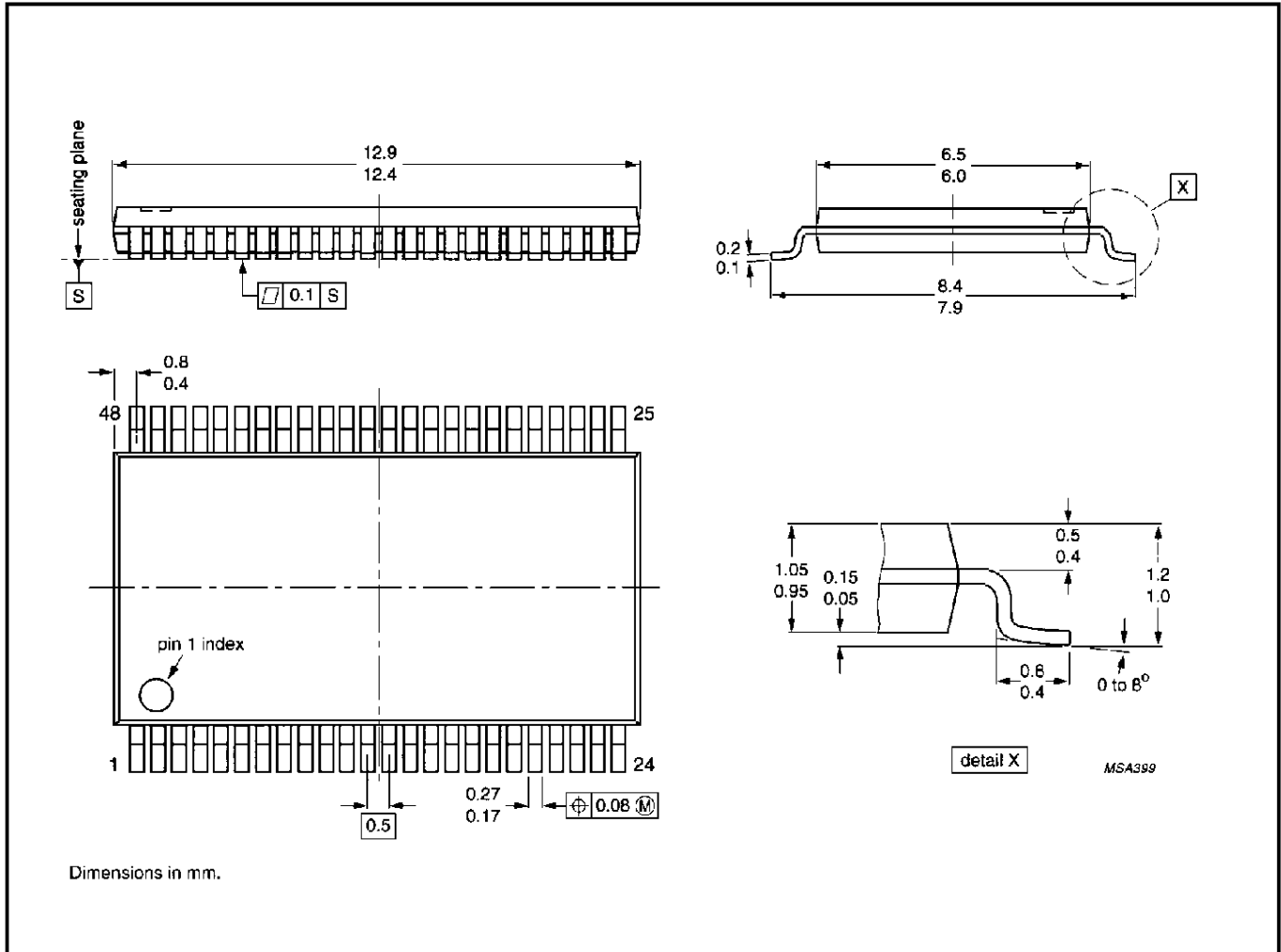

16-bit buffer/line driver (3-State)

74ABT16244A
74ABTH16244A

DEFINITIONS

Data Sheet Identification	Product Status	Definition
<i>Objective Specification</i>	Formative or In Design	This data sheet contains the design target or goal specifications for product development. Specifications may change in any manner without notice.
<i>Preliminary Specification</i>	Preproduction Product	This data sheet contains preliminary data, and supplementary data will be published at a later date. Philips Semiconductors reserves the right to make changes at any time without notice in order to improve design and supply the best possible product.
<i>Product Specification</i>	Full Production	This data sheet contains Final Specifications. Philips Semiconductors reserves the right to make changes at any time without notice, in order to improve design and supply the best possible product.

Philips Semiconductors and Philips Electronics North America Corporation reserve the right to make changes, without notice, in the products, including circuits, standard cells, and/or software, described or contained herein in order to improve design and/or performance. Philips Semiconductors assumes no responsibility or liability for the use of any of these products, conveys no license or title under any patent, copyright, or mask work right to these products, and makes no representations or warranties that these products are free from patent, copyright, or mask work right infringement, unless otherwise specified. Applications that are described herein for any of these products are for illustrative purposes only. Philips Semiconductors makes no representation or warranty that such applications will be suitable for the specified use without further testing or modification.

LIFE SUPPORT APPLICATIONS

Philips Semiconductors and Philips Electronics North America Corporation Products are not designed for use in life support appliances, devices, or systems where malfunction of a Philips Semiconductors and Philips Electronics North America Corporation Product can reasonably be expected to result in a personal injury. Philips Semiconductors and Philips Electronics North America Corporation customers using or selling Philips Semiconductors and Philips Electronics North America Corporation Products for use in such applications do so at their own risk and agree to fully indemnify Philips Semiconductors and Philips Electronics North America Corporation for any damages resulting from such improper use or sale.

Philips Semiconductors
811 East Arques Avenue
P.O. Box 3409
Sunnyvale, California 94088-3409
Telephone 800-234-7381

Philips Semiconductors and Philips Electronics North America Corporation register eligible circuits under the Semiconductor Chip Protection Act.
 © Copyright Philips Electronics North America Corporation 1997
 All rights reserved. Printed in U.S.A.