

Am2956/Am2957

Octal Latches with Three-State Outputs

DISTINCTIVE CHARACTERISTICS

- 8-bit, high-speed parallel latches
- Am2956 has non-inverting inputs
- Am2957 has inverting inputs
- $V_{OL} = 0.5V$ (max) at $I_{OL} = 32mA$
- Hysteresis on latch enable input for improved noise margin
- 3-state outputs interface directly with bus organized systems

GENERAL DESCRIPTION

The Am2956 and Am2957 are octal latches with 3-state outputs for bus organized system applications. The latches appear to be transparent to the data (data changes asynchronously) when latch enable, G, is HIGH. When G is LOW, the data that meets the set-up times is latched. Data appears on the bus when the output enable, \overline{OE} , is LOW.

When \overline{OE} is HIGH the bus output is in the high-impedance state.

The Am2956 presents non-inverted data at the outputs while the Am2957 is inverting.

The devices are packaged in a space-saving (0.3-inch row spacing) 20-pin package.

BLOCK DIAGRAM

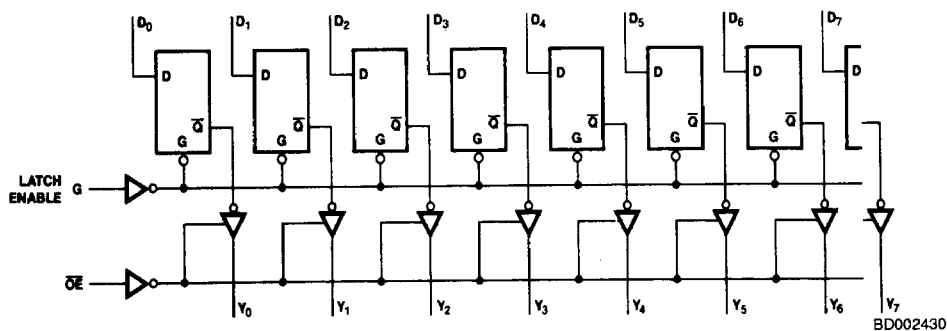

Inputs D_0 through D_7 are inverted on the Am2957.

RELATED PRODUCTS

Part No.	Description
Am29841-46	8, 9, 10-Bit Latches

CONNECTION DIAGRAM Top View

D-20, P-20

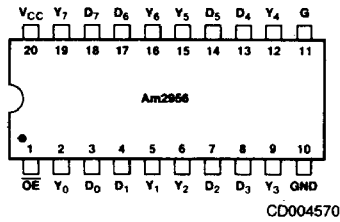

L-20-1

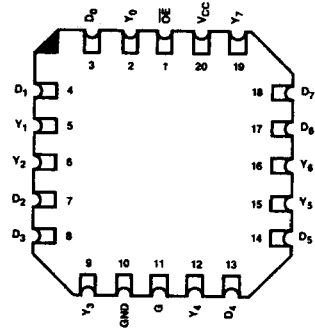

Note: Pin 1 is marked for orientation

F-20 pin configuration identical to D-20, P-20.

LOGIC SYMBOL

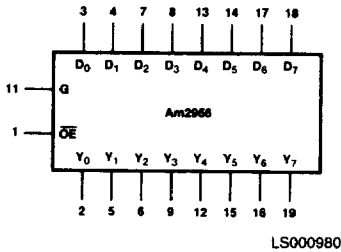

Note: Inputs D_0 through D_7 are inverted on the Am2957

METALLIZATION AND PAD LAYOUT Am2956

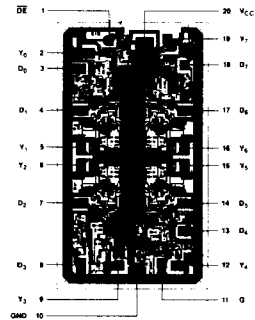

ORDERING INFORMATION

AMD products are available in several packages and operating ranges. The order number is formed by a combination of the following: Device number, speed option (if applicable), package type, operating range and screening option (if desired).

Am2956/2957

D

C

B

Screening Option
Blank - Standard processing
B - Burn-in

Temperature (See Operating Range)
C - Commercial (0°C to +70°C)
M - Military (-55°C to +125°C)

Package
D - 20-pin CERDIP
F - 20-pin flatpak
L - 20-pin leadless chip carrier
P - 20-pin plastic DIP
X - Dice

Device type
Octal Latches with 3-State Outputs

Valid Combinations

Am2956	PC
Am2957	DC, DCB, DM,
	DMB
	FM, FMB
	LC, LCB, LM,
	LMB
	XC, XM

Valid Combinations

Consult the AMD sales office in your area to determine if a device is currently available in the combination you wish.

PIN DESCRIPTION

Pin No.	Name	I/O	Description
	D_i/\bar{D}_i	I	The latch data inputs (Am2956, non-inverting/Am2957, inverting).
11	G	I	The latch enable input. The latches are transparent when G is HIGH. Input data is latched on the HIGH-to-LOW transition.
	Y_i	O	The 3-state latch outputs.
1	$\bar{O}E$	I	The output enable control. When $\bar{O}E$ is LOW, the outputs Y_i are enabled. When $\bar{O}E$ is HIGH, the outputs Y_i are in the high-impedance (off) state.

FUNCTION TABLES

Am2956

Inputs			Internal	Outputs	Function
$\bar{O}E$	G	D_i	Q_i	Y_i	
H	X	X	X	Z	Hi-Z
L	H	L	L	L	Transparent
L	H	H	H	H	
L	L	X	NC	NC	Latched

Am2957

Inputs			Internal	Outputs	Function
$\bar{O}E$	G	\bar{D}_i	Q_i	Y_i	
H	X	X	X	Z	Hi-Z
L	H	L	H	H	Transparent
L	H	H	L	L	
L	L	X	NC	NC	Latched

H = HIGH
 L = LOW
 X = Don't Care
 NC = No Change
 Z = High Impedance

5

APPLICATION

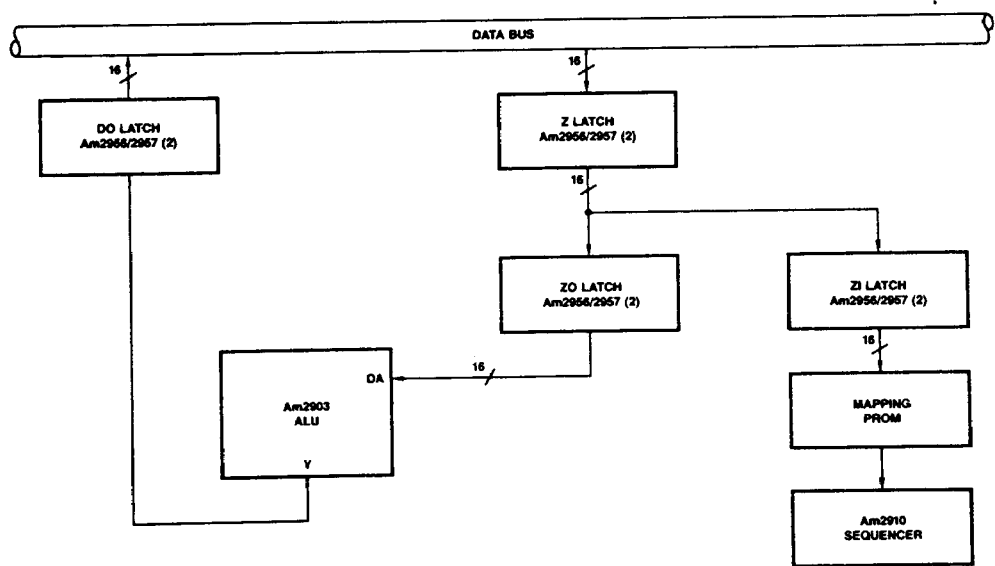

AF001880

Transparent Latches are used in high performance CPU designs. The Z Latch configuration shown provides overlapped fetch of machine instructions and operand data.

ABSOLUTE MAXIMUM RATINGS

Storage Temperature	-65°C to +150°C
(Ambient) Temperature Under Bias	-55°C to +125°C
Supply Voltage to Ground Potential (Pin 16 to Pin 8) Continuous	-0.5V to +7.0V
DC Voltage Applied to Outputs For High Output State	-0.5V to +V _{CC} max
DC Input Voltage	-0.5V to +5.5V
DC Output Current, Into Outputs	30mA
DC Input Current	-30 to +5.0mA

Stresses above those listed under ABSOLUTE MAXIMUM RATINGS may cause permanent device failure. Functionality at or above these limits is not implied. Exposure to absolute maximum ratings for extended periods may affect device reliability.

OPERATING RANGES

Commercial (C) Devices

Temperature	0°C to +70°C
Supply Voltage	+4.75V to +5.25V

Military (M) Devices

Temperature	-55°C to +125°C
Supply Voltage	+4.5V to +5.5V

Operating ranges define those limits over which the functionality of the device is guaranteed.

DC CHARACTERISTICS over operating range unless otherwise specified

Parameters	Description	Test Conditions (Note 2)		Min	Typ (Note 1)	Max	Units
V _{OH}	Output HIGH Voltage	V _{CC} = MIN V _{IN} = V _{IH} or V _{IL}	MIL, I _{OH} = -2.0mA	2.4	3.4		Volts
			COM'L, I _{OH} = -6.5mA	2.4	3.1		
V _{OL}	Output LOW Voltage	V _{CC} = MIN V _{IN} = V _{IH} or V _{IL}	I _{OL} = 20mA			.46	Volts
			I _{OL} = 32mA			.5	
V _{IH}	Input HIGH Level	Guaranteed input logical HIGH voltage for all inputs		2.0			Volts
V _{IL}	Input LOW Level	Guaranteed input logical LOW voltage for all inputs				0.8	Volts
V _I	Input Clamp Voltage	V _{CC} = MIN, I _{IN} = -18mA				-1.2	Volts
I _{IL}	Input LOW Current	V _{CC} = MAX, V _{IN} = 0.5V				-250	μA
I _{IN}	Input HIGH Current	V _{CC} = MAX, V _{IN} = 2.7V				50	μA
I _I	Input HIGH Current	V _{CC} = MAX, V _{IN} = 5.5V				1.0	mA
I _{OZ}	Off-State (High-Impedance) Output Current	V _{CC} = MAX	V _O = 0.5V			-50	μA
			V _O = 2.4V			50	
I _{SC}	Output Short Circuit Current (Note 3)	V _{CC} = MAX		-40		-100	mA
I _{CC}	Power Supply Current (Note 4)	2956	V _{CC} = MAX		105	160	mA
		2957			110	168	

Notes: 1. Typical limits are at V_{CC} = 5.0V, 25°C ambient and maximum loading.

2. For conditions shown as MIN or MAX use the appropriate value specified under Operating Ranges for the applicable device type.

3. Not more than one output should be shorted at a time. Duration of the short circuit test should not exceed one second.

4. Inputs grounded; outputs open.

SWITCHING CHARACTERISTICS ($T_A = +25^\circ\text{C}$, $V_{CC} = 5.0\text{V}$)
Am2956

Parameters	Description	Test Conditions	Min	Typ	Max	Units	
t_{PLH}	Enable to Output	$C_L = 15\text{pF}$ $R_L = 280\Omega$		7	14	ns	
t_{PHL}				12	18	ns	
t_{PLH}	Data Input to Output			5	9	ns	
t_{PHL}				9	13	ns	
$t_s(H)$	HIGH Data to Enable			0		ns	
$t_s(L)$	LOW Data to Enable			0		ns	
$t_h(H)$	HIGH Data to Enable			10		ns	
$t_h(L)$	LOW Data to Enable			10		ns	
t_{pWH}	Enable Pulse Width			6		ns	
t_{pWL}				7.3		ns	
t_{ZH}	\overline{OE} to Y_i				8	15	ns
t_{ZL}					11	18	ns
t_{HZ}	\overline{OE} to Y_i		$C_L = 5\text{pF}$ $R_L = 280\Omega$		6	9	ns
t_{LZ}					8	12	ns

*Switching Characteristics' performance over the operating temperature range is guaranteed by testing defined in Group A, Subgroup 9.

SWITCHING CHARACTERISTICS ($T_A = +25^\circ\text{C}$, $V_{CC} = 5.0\text{V}$)
Am2957

Parameters	Description	Test Conditions	Min	Typ	Max	Units	
t_{PLH}	Enable to Output	$C_L = 15\text{pF}$ $R_L = 280\Omega$		17	24	ns	
t_{PHL}				19	26	ns	
t_{PLH}	Data Input to Output			10	14	ns	
t_{PHL}				14	20	ns	
$t_s(H)$	HIGH Data to Enable			0		ns	
$t_s(L)$	LOW Data to Enable			0		ns	
$t_h(H)$	HIGH Data to Enable			10		ns	
$t_h(L)$	LOW Data to Enable			10		ns	
t_{pWH}	Enable Pulse Width			6		ns	
t_{pWL}				7.3		ns	
t_{ZH}	\overline{OE} to Y_i				8	15	ns
t_{ZL}					11	18	ns
t_{HZ}	\overline{OE} to Y_i		$C_L = 5\text{pF}$ $R_L = 280\Omega$		6	9	ns
t_{LZ}					8	10	ns