

HD74HC76

Dual J-K Flip-Flops (with Preset and Clear)

REJ03D0551-0200
 (Previous ADE-205-423)
 Rev.2.00
 Oct 06, 2005

Description

Each flip-flop has independent J, K, preset, clear, and clock inputs and Q and \bar{Q} outputs. This device is edge sensitive to the clock input and change state on the negative going transition of the clock pulse. Clear and preset are independent of the clock and accomplished by a low logic level on the corresponding input.





Features

- High Speed Operation: t_{pd} (Clock to Q) = 21 ns typ ($C_L = 50$ pF)
- High Output Current: Fanout of 10 LSTTL Loads
- Wide Operating Voltage: $V_{CC} = 2$ to 6 V
- Low Input Current: 1 μ A max
- Low Quiescent Supply Current: I_{CC} (static) = 2 μ A max ($T_a = 25^\circ\text{C}$)
- Ordering Information

| Part Name | Package Type | Package Code (Previous Code) | Package Abbreviation | Taping Abbreviation (Quantity) |
|--------------|--------------------|------------------------------|----------------------|--------------------------------|
| HD74HC76P | DILP-16 pin | PRDP0016AE-B (DP-16FV) | P | — |
| HD74HC76FPEL | SOP-16 pin (JEITA) | PRSP0016DH-B (FP-16DAV) | FP | EL (2,000 pcs/reel) |

Note: Please consult the sales office for the above package availability.

Function Table

| Inputs | | | | | Outputs | |
|--------|-------|---|---|---|-----------|-----------|
| Preset | Clear | Clock | J | K | Q | \bar{Q} |
| L | H | X | X | X | H | L |
| H | L | X | X | X | L | H |
| L | L | X | X | X | H^{*1} | H^{*1} |
| H | H |  | L | L | No change | |
| H | H |  | L | H | L | H |
| H | H |  | H | L | H | L |
| H | H |  | H | H | Toggle | |
| H | H | L | X | X | No change | |
| H | H | H | X | X | No change | |
| H | H |  | X | X | No change | |

H : High level

L : Low level

X : Irrelevant

Note: 1. Q and \bar{Q} will remain High as long as Preset and Clear are Low, but Q and \bar{Q} are unpredictable, if Preset and Clear go High simultaneously.

Pin Arrangement

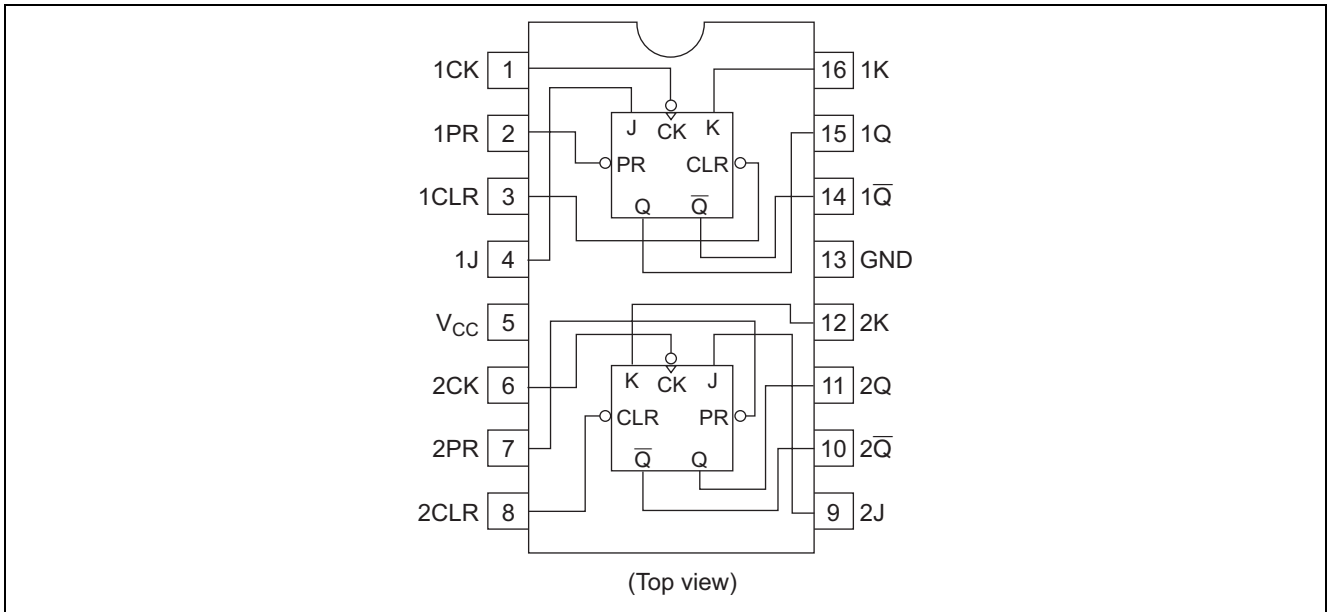

Logic Diagram (1/2)

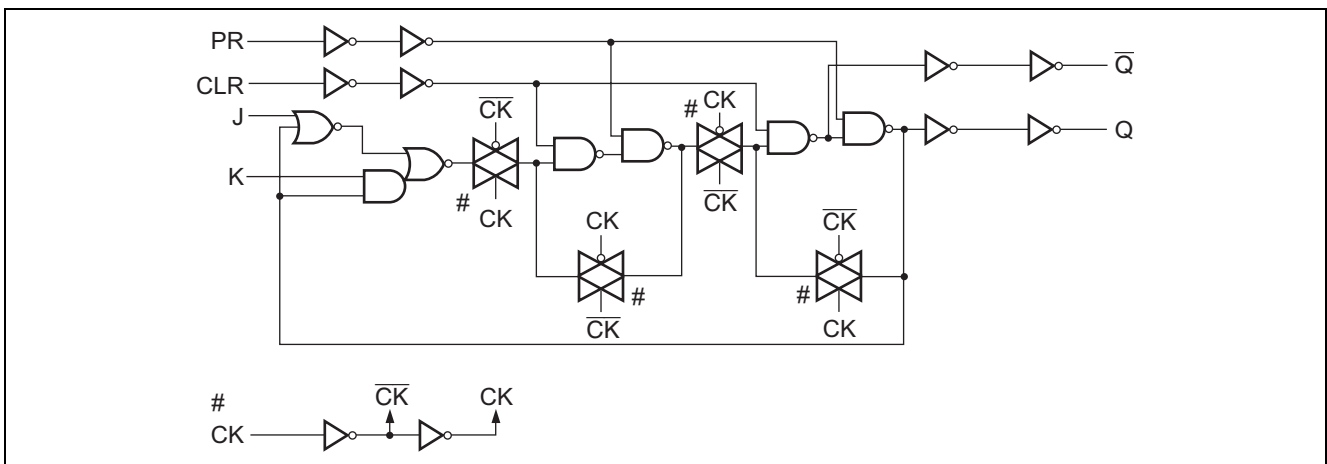

Absolute Maximum Ratings

| Item | Symbol | Ratings | Unit |
|------------------------------|-----------------------|------------------------|-------------|
| Supply voltage range | V_{CC} | -0.5 to 7.0 | V |
| Input / Output voltage | V_{in}, V_{out} | -0.5 to $V_{CC} + 0.5$ | V |
| Input / Output diode current | I_{IK}, I_{OK} | ± 20 | mA |
| Output current | I_O | ± 25 | mA |
| V_{CC}, GND current | I_{CC} or I_{GND} | ± 50 | mA |
| Power dissipation | P_T | 500 | mW |
| Storage temperature | T_{stg} | -65 to +150 | $^{\circ}C$ |

Note: The absolute maximum ratings are values, which must not individually be exceeded, and furthermore, no two of which may be realized at the same time.

Recommended Operating Conditions

| Item | Symbol | Ratings | Unit | Conditions |
|--------------------------------------|-------------------|---------------|------|-------------------------|
| Supply voltage | V_{CC} | 2 to 6 | V | |
| Input / Output voltage | V_{IN}, V_{OUT} | 0 to V_{CC} | V | |
| Operating temperature | T_a | -40 to 85 | °C | |
| Input rise / fall time ^{*1} | t_r, t_f | 0 to 1000 | ns | $V_{CC} = 2.0\text{ V}$ |
| | | 0 to 500 | | $V_{CC} = 4.5\text{ V}$ |
| | | 0 to 400 | | $V_{CC} = 6.0\text{ V}$ |

Note: 1. This item guarantees maximum limit when one input switches.
 Waveform: Refer to test circuit of switching characteristics.

Electrical Characteristics

| Item | Symbol | V_{CC} (V) | $T_a = 25^\circ\text{C}$ | | | $T_a = -40\text{ to }+85^\circ\text{C}$ | | Unit | Test Conditions | |
|--------------------------|----------|--------------|--------------------------|-----|-----------|---|-----------|---------------|---|-----------------------------|
| | | | Min | Typ | Max | Min | Max | | | |
| Input voltage | V_{IH} | 2.0 | 1.5 | — | — | 1.5 | — | V | | |
| | | 4.5 | 3.15 | — | — | 3.15 | — | | | |
| | | 6.0 | 4.2 | — | — | 4.2 | — | | | |
| | V_{IL} | 2.0 | — | — | 0.5 | — | 0.5 | V | | |
| | | 4.5 | — | — | 1.35 | — | 1.35 | | | |
| | | 6.0 | — | — | 1.8 | — | 1.8 | | | |
| Output voltage | V_{OH} | 2.0 | 1.9 | 2.0 | — | 1.9 | — | V | $V_{in} = V_{IH}\text{ or }V_{IL}$ | $I_{OH} = -20\ \mu\text{A}$ |
| | | 4.5 | 4.4 | 4.5 | — | 4.4 | — | | | $I_{OH} = -4\ \text{mA}$ |
| | | 6.0 | 5.9 | 6.0 | — | 5.9 | — | | | $I_{OH} = -5.2\ \text{mA}$ |
| | | 4.5 | 4.18 | — | — | 4.13 | — | | | |
| | | 6.0 | 5.68 | — | — | 5.63 | — | | | |
| | V_{OL} | 2.0 | — | 0.0 | 0.1 | — | 0.1 | V | $V_{in} = V_{IH}\text{ or }V_{IL}$ | $I_{OL} = 20\ \mu\text{A}$ |
| | | 4.5 | — | 0.0 | 0.1 | — | 0.1 | | | |
| | | 6.0 | — | 0.0 | 0.1 | — | 0.1 | | | |
| | | 4.5 | — | — | 0.26 | — | 0.33 | | | $I_{OL} = 4\ \text{mA}$ |
| | | 6.0 | — | — | 0.26 | — | 0.33 | | | $I_{OL} = 5.2\ \text{mA}$ |
| Input current | I_{in} | 6.0 | — | — | ± 0.1 | — | ± 1.0 | μA | $V_{in} = V_{CC}\text{ or GND}$ | |
| Quiescent supply current | I_{CC} | 6.0 | — | — | 2.0 | — | 20 | μA | $V_{in} = V_{CC}\text{ or GND, }I_{out} = 0\ \mu\text{A}$ | |

Switching Characteristics ($C_L = 50\ \text{pF}$, Input $t_r = t_f = 6\ \text{ns}$)

| Item | Symbol | V_{CC} (V) | $T_a = 25^\circ\text{C}$ | | | $T_a = -40\text{ to }+85^\circ\text{C}$ | | Unit | Test Conditions | | |
|-------------------------|--------------------|--------------|--------------------------|-----|-----|---|-----|------|-------------------------|--------------------------|--|
| | | | Min | Typ | Max | Min | Max | | | | |
| Maximum clock frequency | f_{max} | 2.0 | — | — | 6 | — | 5 | MHz | | | |
| | | 4.5 | — | — | 30 | — | 24 | | | | |
| | | 6.0 | — | — | 35 | — | 28 | | | | |
| Propagation delay time | t_{PLH}, t_{PHL} | 2.0 | — | — | 150 | — | 190 | ns | Clock to Q or \bar{Q} | | |
| | | 4.5 | — | 21 | 30 | — | 38 | | | | |
| | | 6.0 | — | — | 26 | — | 33 | | | | |
| | | | 2.0 | — | — | 140 | — | 175 | ns | Clear to Q or \bar{Q} | |
| | | | 4.5 | — | 17 | 28 | — | 35 | | | |
| | | | 6.0 | — | — | 24 | — | 30 | | | |
| | | | 2.0 | — | — | 140 | — | 175 | ns | Preset to Q or \bar{Q} | |
| | | | 4.5 | — | 19 | 28 | — | 35 | | | |
| | | | 6.0 | — | — | 24 | — | 30 | | | |

Switching Characteristics ($C_L = 50 \text{ pF}$, Input $t_r = t_f = 6 \text{ ns}$)

| Item | Symbol | V_{CC} (V) | $T_a = 25^\circ\text{C}$ | | | $T_a = -40 \text{ to } +85^\circ\text{C}$ | | Unit | Test Conditions |
|-----------------------|--------------------|--------------|--------------------------|-----|-----|---|-----|------|--------------------------|
| | | | Min | Typ | Max | Min | Max | | |
| Pulse width | t_w | 2.0 | 80 | — | — | 100 | — | ns | Preset, Clear, Clock |
| | | 4.5 | 16 | 6 | — | 20 | — | | |
| | | 6.0 | 14 | — | — | 17 | — | | |
| Setup time | t_{su} | 2.0 | 100 | — | — | 125 | — | ns | J or K to Clock |
| | | 4.5 | 20 | 4 | — | 25 | — | | |
| | | 6.0 | 17 | — | — | 21 | — | | |
| Hold time | t_h | 2.0 | 0 | — | — | 0 | — | ns | Clock to J or K |
| | | 4.5 | 0 | -3 | — | 0 | — | | |
| | | 6.0 | 0 | — | — | 0 | — | | |
| Removal time | t_{rem} | 2.0 | 100 | — | — | 125 | — | ns | Preset or Clear to Clock |
| | | 4.5 | 20 | -2 | — | 25 | — | | |
| | | 6.0 | 17 | — | — | 21 | — | | |
| Output rise/fall time | t_{TLH}, t_{THL} | 2.0 | — | — | 75 | — | 95 | ns | |
| | | 4.5 | — | 5 | 15 | — | 19 | | |
| | | 6.0 | — | — | 13 | — | 16 | | |
| Input capacitance | C_{in} | — | — | 5 | 10 | — | 10 | pF | |

Test Circuit

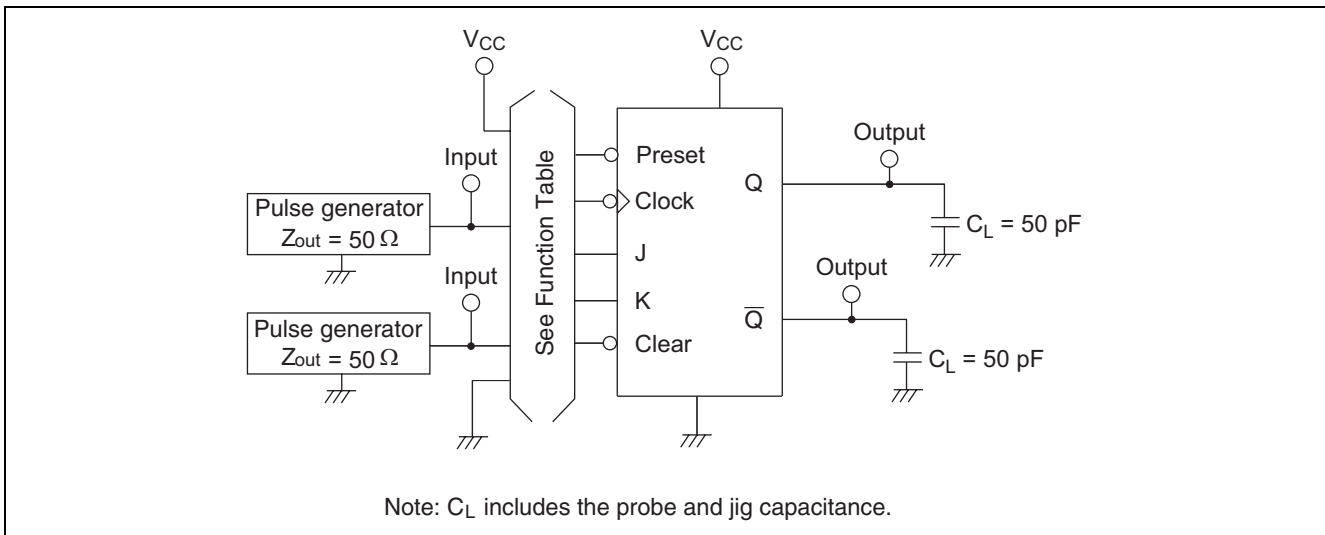

Waveforms

• Waveform – 1

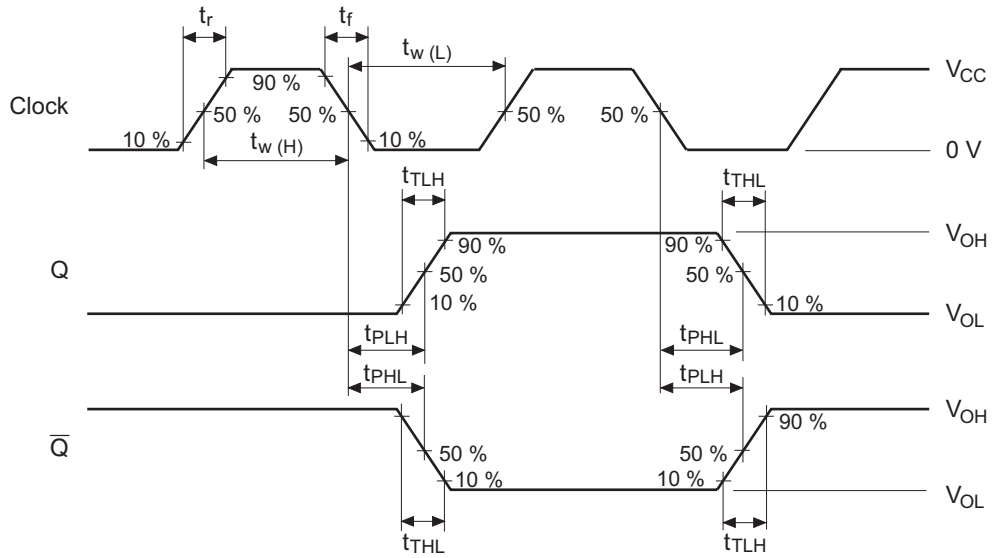

• Waveform – 2

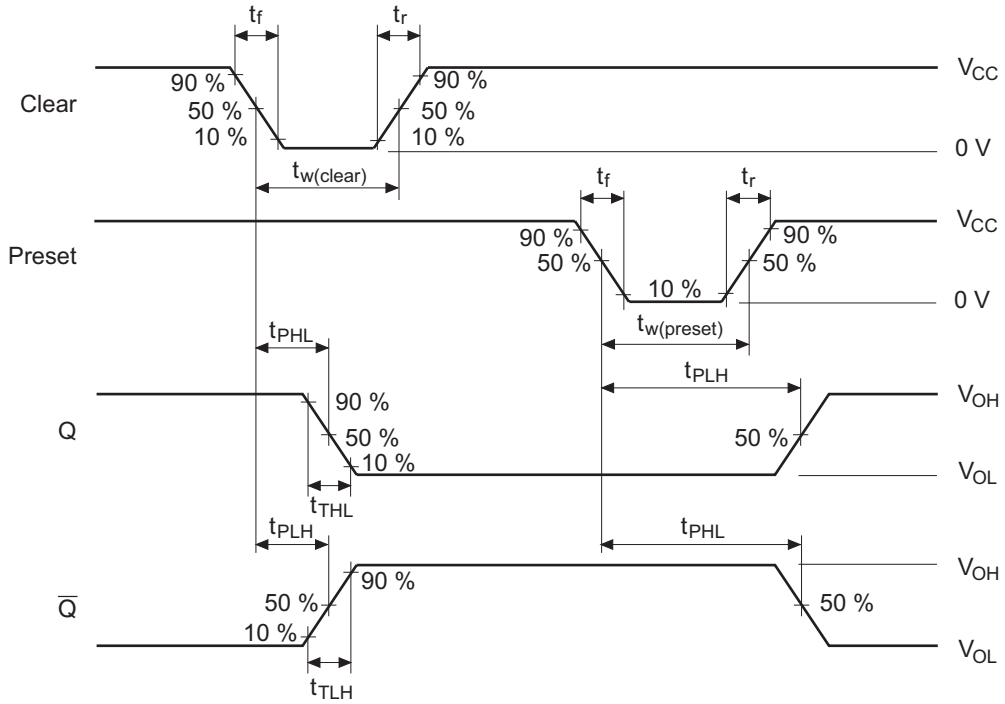

- Notes: 1. Input waveform: $PRR \leq 1 \text{ MHz}$, $Z_o = 50 \Omega$, $t_r \leq 6 \text{ ns}$, $t_f \leq 6 \text{ ns}$
 2. The output are measured one at a time with one transition per measurement.

Package Dimensions

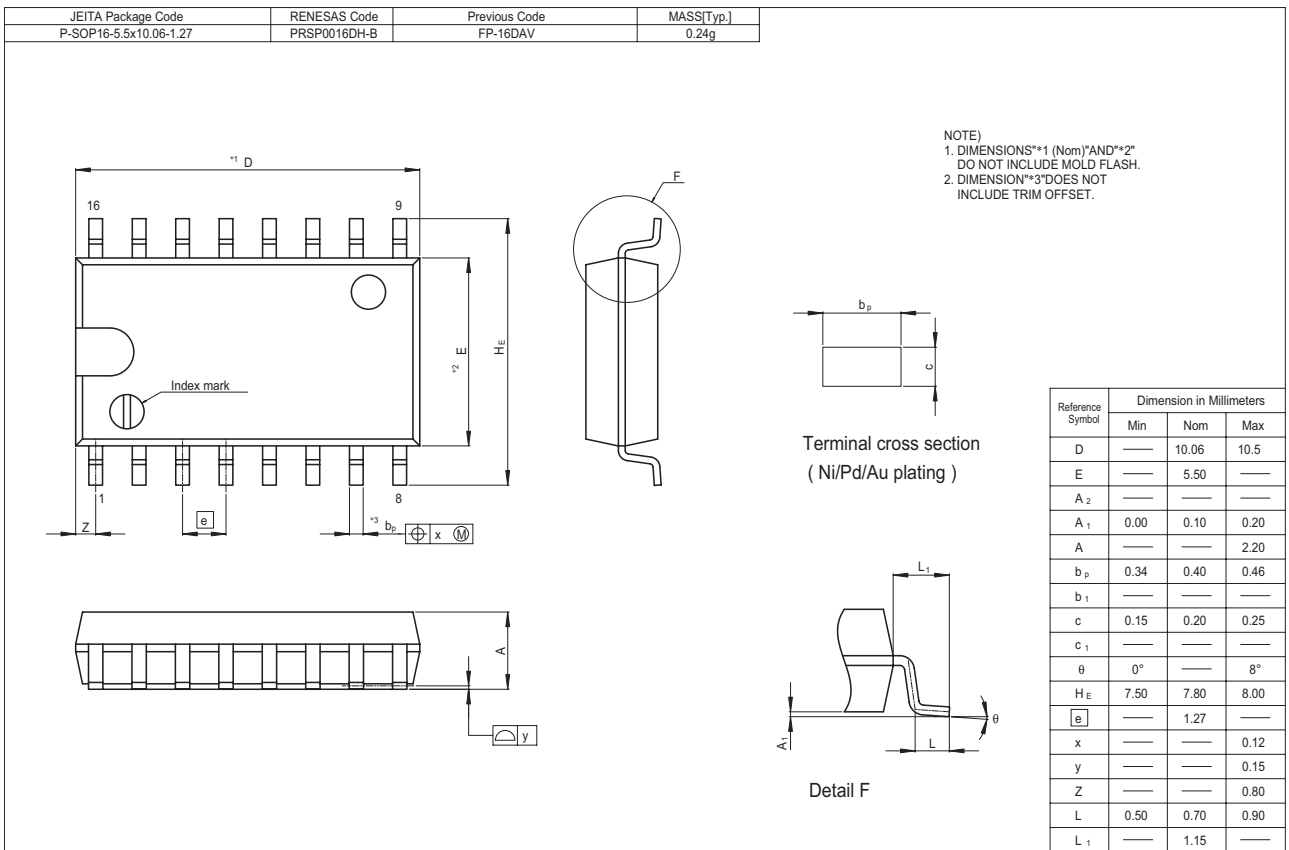
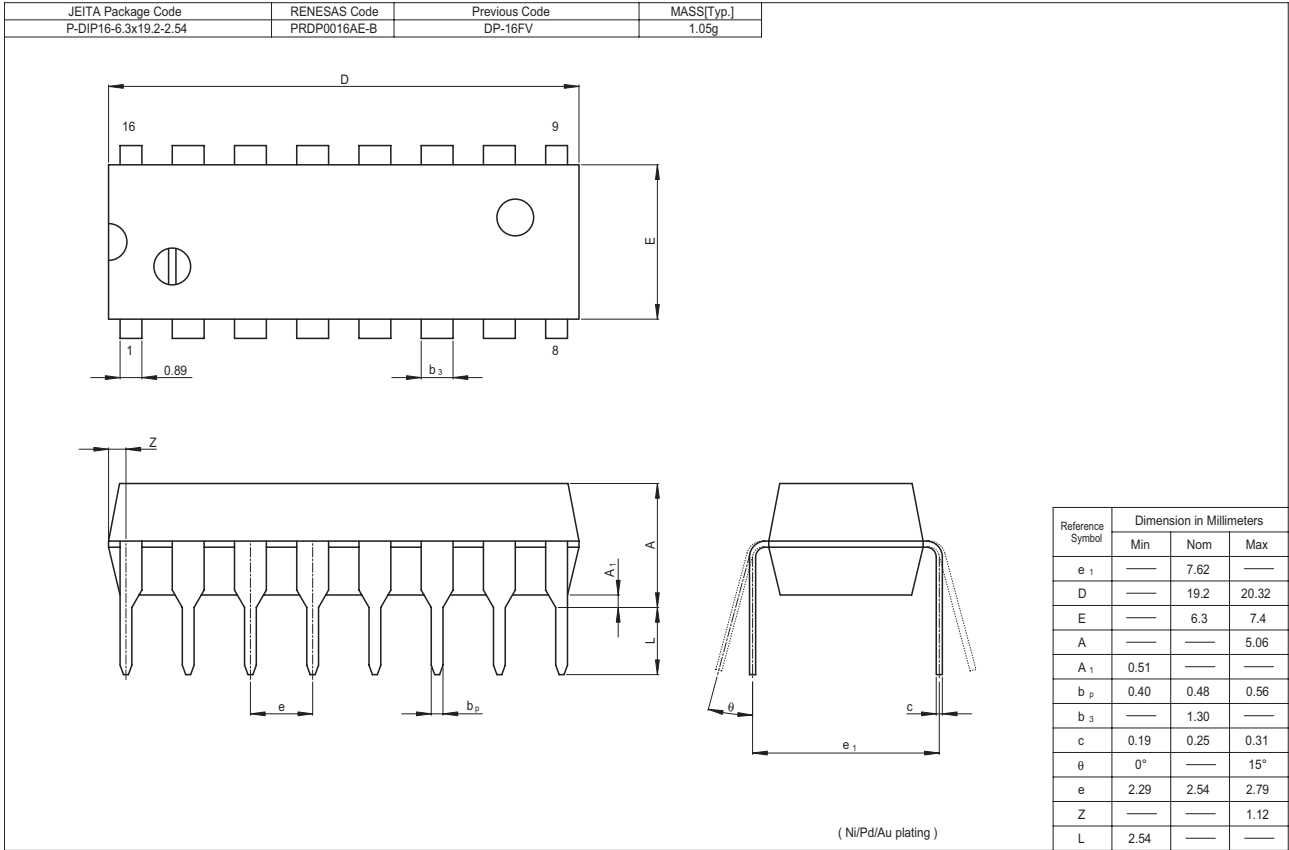

Renesas Technology Corp. Sales Strategic Planning Div. Nippon Bldg., 2-6-2, Ohte-machi, Chiyoda-ku, Tokyo 100-0004, Japan

Keep safety first in your circuit designs!

1. Renesas Technology Corp. puts the maximum effort into making semiconductor products better and more reliable, but there is always the possibility that trouble may occur with them. Trouble with semiconductors may lead to personal injury, fire or property damage. Remember to give due consideration to safety when making your circuit designs, with appropriate measures such as (i) placement of substitutive, auxiliary circuits, (ii) use of nonflammable material or (iii) prevention against any malfunction or mishap.

Notes regarding these materials

1. These materials are intended as a reference to assist our customers in the selection of the Renesas Technology Corp. product best suited to the customer's application; they do not convey any license under any intellectual property rights, or any other rights, belonging to Renesas Technology Corp. or a third party.
2. Renesas Technology Corp. assumes no responsibility for any damage, or infringement of any third-party's rights, originating in the use of any product data, diagrams, charts, programs, algorithms, or circuit application examples contained in these materials.
3. All information contained in these materials, including product data, diagrams, charts, programs and algorithms represents information on products at the time of publication of these materials, and are subject to change by Renesas Technology Corp. without notice due to product improvements or other reasons. It is therefore recommended that customers contact Renesas Technology Corp. or an authorized Renesas Technology Corp. product distributor for the latest product information before purchasing a product listed herein.
The information described here may contain technical inaccuracies or typographical errors.
Renesas Technology Corp. assumes no responsibility for any damage, liability, or other loss rising from these inaccuracies or errors.
Please also pay attention to information published by Renesas Technology Corp. by various means, including the Renesas Technology Corp. Semiconductor home page (<http://www.renesas.com>).
4. When using any or all of the information contained in these materials, including product data, diagrams, charts, programs, and algorithms, please be sure to evaluate all information as a total system before making a final decision on the applicability of the information and products. Renesas Technology Corp. assumes no responsibility for any damage, liability or other loss resulting from the information contained herein.
5. Renesas Technology Corp. semiconductors are not designed or manufactured for use in a device or system that is used under circumstances in which human life is potentially at stake. Please contact Renesas Technology Corp. or an authorized Renesas Technology Corp. product distributor when considering the use of a product contained herein for any specific purposes, such as apparatus or systems for transportation, vehicular, medical, aerospace, nuclear, or undersea repeater use.
6. The prior written approval of Renesas Technology Corp. is necessary to reprint or reproduce in whole or in part these materials.
7. If these products or technologies are subject to the Japanese export control restrictions, they must be exported under a license from the Japanese government and cannot be imported into a country other than the approved destination.
Any diversion or reexport contrary to the export control laws and regulations of Japan and/or the country of destination is prohibited.
8. Please contact Renesas Technology Corp. for further details on these materials or the products contained therein.



RENESAS SALES OFFICES

<http://www.renesas.com>

Refer to "<http://www.renesas.com/en/network>" for the latest and detailed information.

Renesas Technology America, Inc.

450 Holger Way, San Jose, CA 95134-1368, U.S.A
Tel: <1> (408) 382-7500, Fax: <1> (408) 382-7501

Renesas Technology Europe Limited

Dukes Meadow, Millboard Road, Bourne End, Buckinghamshire, SL8 5FH, U.K.
Tel: <44> (1628) 585-100, Fax: <44> (1628) 585-900

Renesas Technology Hong Kong Ltd.

7th Floor, North Tower, World Finance Centre, Harbour City, 1 Canton Road, Tsimshatsui, Kowloon, Hong Kong
Tel: <852> 2265-6688, Fax: <852> 2730-6071

Renesas Technology Taiwan Co., Ltd.

10th Floor, No.99, Fushing North Road, Taipei, Taiwan
Tel: <886> (2) 2715-2888, Fax: <886> (2) 2713-2999

Renesas Technology (Shanghai) Co., Ltd.

Unit2607 Ruijing Building, No.205 Maoming Road (S), Shanghai 200020, China
Tel: <86> (21) 6472-1001, Fax: <86> (21) 6415-2952

Renesas Technology Singapore Pte. Ltd.

1 Harbour Front Avenue, #06-10, Keppel Bay Tower, Singapore 098632
Tel: <65> 6213-0200, Fax: <65> 6278-8001

Renesas Technology Korea Co., Ltd.

Kukje Center Bldg. 18th Fl., 191, 2-ka, Hangang-ro, Yongsan-ku, Seoul 140-702, Korea
Tel: <82> 2-796-3115, Fax: <82> 2-796-2145

Renesas Technology Malaysia Sdn. Bhd.

Unit 906, Block B, Menara Amcorp, Amcorp Trade Centre, No.18, Jalan Persiaran Barat, 46050 Petaling Jaya, Selangor Darul Ehsan, Malaysia
Tel: <603> 7955-9390, Fax: <603> 7955-9510