



Integrated Device Technology, Inc.

# CMOS STATIC RAM 256K (32K x 8-BIT)

IDT71256S  
IDT71256L

## FEATURES:

- High-speed address/chip select time
  - Military: 25/30/35/45/55/70/85/100/120/150ns (max.)
  - Commercial: 20/25/35/45ns (max.) Low Power only.
- Low-power operation
- Battery Backup operation — 2V data retention
- Produced with advanced high-performance CMOS technology
- Input and output directly TTL-compatible
- Available in standard 28-pin (300 or 600 mil) ceramic DIP, 28-pin (600 mil) plastic DIP, 28-pin (300 mil) SOJ and 32-pin LCC
- Military product compliant to MIL-STD-883, Class B

## DESCRIPTION:

The IDT71256 is a 262,144-bit high-speed static RAM organized as 32K x 8. It is fabricated using IDT's high-performance, high-reliability CMOS technology.

Address access times as fast as 20ns are available with power consumption of only 350mW (typ.). The circuit also offers a reduced power standby mode. When  $\overline{CS}$  goes HIGH, the circuit will automatically go to, and remain in, a low-power standby mode as long as  $\overline{CS}$  remains HIGH. In the full standby mode, the low-power device consumes less than 15 $\mu$ W, typically. This capability provides significant system level power and cooling savings. The low-power (L) version also offers a battery backup data retention capability where the circuit typically consumes only 5 $\mu$ W when operating off a 2V battery.

The IDT71256 is packaged in a 28-pin (300 or 600 mil) ceramic DIP, a 28-pin 300 mil J-bend SOIC, and a 28-pin (600 mil) plastic DIP, and 32-pin LCC providing high board-level packing densities.

The IDT71256 military RAM is manufactured in compliance with the latest revision of MIL-STD-883, Class B, making it ideally suited to military temperature applications demanding the highest level of performance and reliability.

## FUNCTIONAL BLOCK DIAGRAM

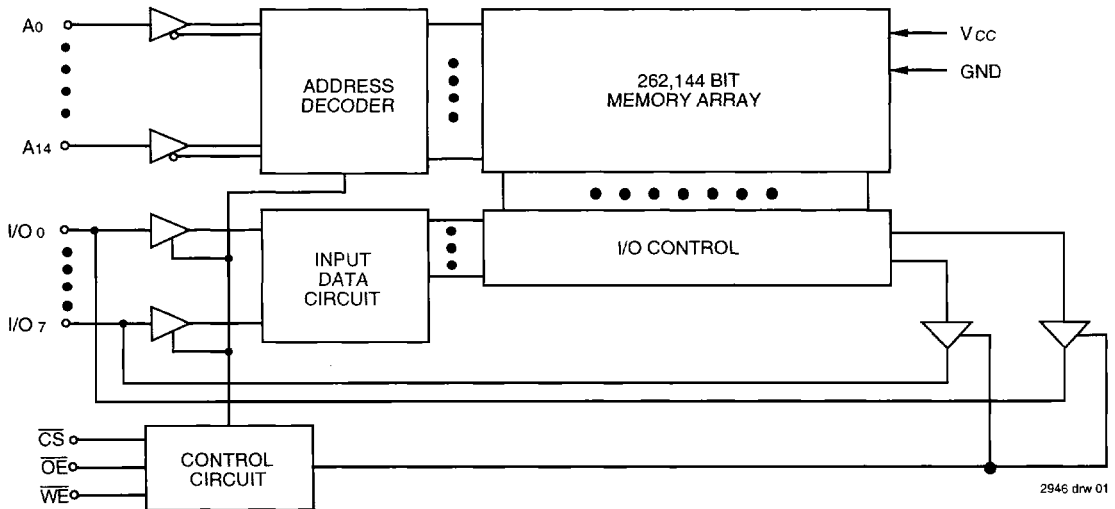

2946 drw 01

The IDT logo is a registered trademark of Integrated Device Technology, Inc.

MILITARY AND COMMERCIAL TEMPERATURE RANGES

AUGUST 1996

**PIN CONFIGURATIONS**

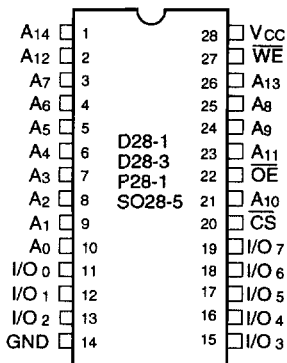

2946 drw 02

**DIP/SOJ  
TOP VIEW**

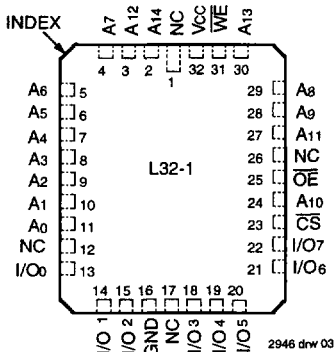

2946 drw 03

**32-Pin LCC  
TOP VIEW**

**TRUTH TABLE<sup>(1)</sup>**

WE	CS	OE	I/O	Function
X	H	X	High-Z	Standby (Isb)
X	VHc	X	High-Z	Standby (Isb1)
H	L	H	High-Z	Output Disabled
H	L	L	DOUT	Read Data
L	L	X	DIN	Write Data

**NOTE:**

1. H = V<sub>IH</sub>, L = V<sub>IL</sub>, X = Don't Care

2946 tbl 02

**ABSOLUTE MAXIMUM RATINGS<sup>(1)</sup>**

Symbol	Rating	Com'l.	Mil.	Unit
VTERM	Terminal Voltage with Respect to GND	-0.5 to +7.0	-0.5 to +7.0	V
TA	Operating Temperature	0 to +70	-55 to +125	°C
TBIAS	Temperature Under Bias	-55 to +125	-65 to +135	°C
TSTG	Storage Temperature	-55 to +125	-65 to +150	°C
Pr	Power Dissipation	1.0	1.0	W
IOUT	DC Output Current	50	50	mA

**NOTE:**

1. Stresses greater than those listed under ABSOLUTE MAXIMUM RATINGS may cause permanent damage to the device. This is a stress rating only and functional operation of the device at these or any other conditions above those indicated in the operational sections of this specification is not implied. Exposure to absolute maximum rating conditions for extended periods may affect reliability.

2946 tbl 03



**PIN DESCRIPTIONS**

Name	Description
A0-A14	Addresses
I/O <sub>0</sub> -I/O <sub>7</sub>	Data Input/Output
CS	Chip Select
WE	Write Enable
OE	Output Enable
GND	Ground
VCC	Power

2946 tbl 01

**CAPACITANCE (TA = +25°C, f = 1.0MHz)**

Symbol	Parameter <sup>(1)</sup>	Conditions	Max.	Unit
CIN	Input Capacitance	V <sub>IN</sub> = 0V	8	pF
C <sub>I/O</sub>	I/O Capacitance	V <sub>OUT</sub> = 0V	8	pF

**NOTE:**

1. This parameter is determined by device characterization, but is not production tested.

2946 tbl 04

**RECOMMENDED OPERATING TEMPERATURE AND SUPPLY VOLTAGE**

Grade	Temperature	GND	Vcc
Military	-55°C to +125°C	0V	5.0V ± 10%
Commercial	0°C to +70°C	0V	5.0V ± 10%

2946 tbl 05

**RECOMMENDED DC OPERATING CONDITIONS**

Symbol	Parameter	Min.	Typ.	Max.	Unit
Vcc	Supply Voltage	4.5	5.0	5.5	V
GND	Supply Voltage	0	0	0	V
V <sub>IH</sub>	Input High Voltage	2.2	—	6.0	V
V <sub>IL</sub>	Input Low Voltage	-0.5 <sup>(1)</sup>	—	0.8	V

**NOTE:**

2946 tbl 06

1. V<sub>IL</sub> (min.) = -3.0V for pulse width less than 20ns, once per cycle.

**DC ELECTRICAL CHARACTERISTICS<sup>(1, 2)</sup>**

(Vcc = 5.0V ± 10%, V<sub>LC</sub> = 0.2V, V<sub>HC</sub> = Vcc - 0.2V)

Symbol	Parameter	Power	71256S/L20		71256S/L25		71256S/L30		71256S/L35		Unit
			Com'l.	Mil.	Com'l.	Mil.	Com'l.	Mil.	Com'l.	Mil.	
I <sub>CC</sub>	Dynamic Operating Current CS ≤ V <sub>IL</sub> , Outputs Open Vcc = Max., f = f <sub>MAX</sub> <sup>(2)</sup>	S	—	—	—	150	—	145	—	.140	mA
		L	135	—	115	130	—	125	105	120	
I <sub>SB</sub>	Standby Power Supply Current (TTL Level) CS ≥ V <sub>IH</sub> , Vcc = Max., Outputs Open, f = f <sub>MAX</sub> <sup>(2)</sup>	S	—	—	—	20	—	20	—	20	mA
		L	3	—	3	3	—	3	3	3	
I <sub>SB1</sub>	Full Standby Power Supply Current (CMOS Level) CS ≥ V <sub>HC</sub> , Vcc = Max., f = 0	S	—	—	—	20	—	20	—	20	mA
		L	0.4	—	0.4	1.5	—	1.5	0.4	1.5	

Symbol	Parameter	Power	71256S/L45		71256S/L55		71256S/L70		71256S/L85 <sup>(3)</sup>		71256S/L100 <sup>(3)</sup>		Unit
			Com'l.	Mil.	Com'l.	Mil.	Com'l.	Mil.	Com'l.	Mil.	Com'l.	Mil.	
I <sub>CC</sub>	Dynamic Operating Current CS ≤ V <sub>IL</sub> , Outputs Open Vcc = Max., f = f <sub>MAX</sub> <sup>(2)</sup>	S	—	135	—	135	—	135	—	135	—	135	mA
		L	100	115	—	115	—	115	—	115	—	115	
I <sub>SB</sub>	Standby Power Supply Current (TTL Level) CS ≥ V <sub>IH</sub> , Vcc = Max., Outputs Open, f = f <sub>MAX</sub> <sup>(2)</sup>	S	—	20	—	20	—	20	—	20	—	20	mA
		L	3	3	—	3	—	3	—	3	—	3	
I <sub>SB1</sub>	Full Standby Power Supply Current (CMOS Level) CS ≥ V <sub>HC</sub> , Vcc = Max., f = 0	S	—	20	—	20	—	20	—	20	—	20	mA
		L	0.4	1.5	—	1.5	—	1.5	—	1.5	—	1.5	

**NOTES:**

2946 tbl 07

1. All values are maximum guaranteed values.
2. f<sub>MAX</sub> = 1/t<sub>RC</sub>, all address inputs cycling at f<sub>MAX</sub>; f = 0 means no address pins are cycling.
3. Also available: 120 and 150 ns military devices.

**AC TEST CONDITIONS**

Input Pulse Levels	GND to 3.0V
Input Rise/Fall Times	5ns
Input Timing Reference Levels	1.5V
Output Reference Levels	1.5V
AC Test Load	See Figures 1 and 2

2946 tbl 08

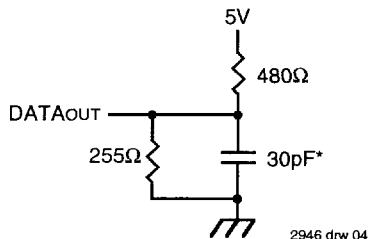

Figure 1. AC Test Load

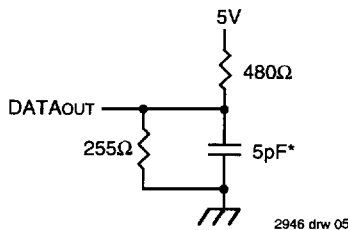

Figure 2. AC Test Load  
(for tCLZ, tOLZ, tCHZ, tOHZ, tLOW, tWHZ)

\*Includes scope and jig capacitances

**DC ELECTRICAL CHARACTERISTICS**

VCC = 5.0V ± 10%

Symbol	Parameter	Test Condition	IDT71256S			IDT71256L			Unit
			Min.	Typ.	Max.	Min.	Typ.	Max.	
II <sub>L</sub>	Input Leakage Current	V <sub>CC</sub> = Max., V <sub>IN</sub> = GND to V <sub>CC</sub>	MIL. COM'L.	— —	10 5	— —	— —	5 2	μA
II <sub>OL</sub>	Output Leakage Current	V <sub>CC</sub> = Max., $\overline{CS} = V_{IH}$ , V <sub>OUT</sub> = GND to V <sub>CC</sub>	MIL. COM'L.	— —	10 5	— —	— —	5 2	μA
V <sub>OL</sub>	Output Low Voltage	IO <sub>L</sub> = 8mA, V <sub>CC</sub> = Min.		—	0.4	—	—	0.4	V
		IO <sub>L</sub> = 10mA, V <sub>CC</sub> = Min.		—	0.5	—	—	0.5	
V <sub>OH</sub>	Output High Voltage	IO <sub>H</sub> = -4mA, V <sub>CC</sub> = Min.		2.4	—	—	2.4	—	V

2946 tbl 09

**DATA RETENTION CHARACTERISTICS OVER ALL TEMPERATURE RANGES**

(L Version Only) V<sub>LC</sub> = 0.2V, V<sub>HC</sub> = V<sub>CC</sub> - 0.2V

Symbol	Parameter	Test Condition	Min.	Typ. <sup>(1)</sup> V <sub>CC</sub> @		Max. V <sub>CC</sub> @		Unit	
				2.0v	3.0V	2.0V	3.0V		
V <sub>DR</sub>	V <sub>CC</sub> for Data Retention	—	2.0	—	—	—	—	V	
I <sub>CCDR</sub>	Data Retention Current	$\overline{CS} \geq V_{HC}$	MIL.	—	—	—	500	800	μA
			COM'L.	—	—	—	120	200	
t <sub>CDR</sub>	Chip Deselect to Data Retention Time	$\overline{CS} \geq V_{HC}$	0	—	—	—	—	ns	
t <sub>R</sub> <sup>(3)</sup>	Operation Recovery Time		t <sub>RC</sub> <sup>(2)</sup>	—	—	—	—	ns	

**NOTES:**

- TA = +25°C.
- t<sub>RC</sub> = Read Cycle Time.
- This parameter is guaranteed, but not tested.

2946 tbl 10

**LOW V<sub>CC</sub> DATA RETENTION WAVEFORM**

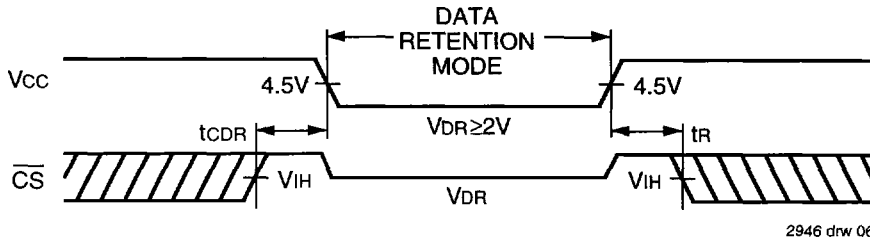

**AC ELECTRICAL CHARACTERISTICS** (V<sub>CC</sub> = 5.0V ± 10%, All Temperature Ranges)

Symbol	Parameter	71256L20 <sup>(1)</sup>		71256S25 71256L25		71256S30 <sup>(3)</sup> 71256L30 <sup>(9)</sup>		71256S35 71256L35		71256S45 71256L45		Unit
		Min.	Max.	Min.	Max.	Min.	Max.	Min.	Max.	Min.	Max.	
		<b>Read Cycle</b>										
t <sub>RC</sub>	Read Cycle Time	20	—	25	—	30	—	35	—	45	—	ns
t <sub>AA</sub>	Address Access Time	—	20	—	25	—	30	—	35	—	45	ns
t <sub>ACS</sub>	Chip Select Access Time	—	20	—	25	—	30	—	35	—	45	ns
t <sub>CLZ</sub> <sup>(2)</sup>	Chip Select to Output in Low-Z	5	—	5	—	5	—	5	—	5	—	ns
t <sub>CHZ</sub> <sup>(2)</sup>	Chip Deselect to Output in High-Z	—	10	—	11	—	15	—	15	—	20	ns
t <sub>OE</sub>	Output Enable to Output Valid	—	10	—	11	—	13	—	15	—	20	ns
t <sub>OLZ</sub> <sup>(2)</sup>	Output Enable to Output in Low-Z	2	—	2	—	2	—	2	—	0	—	ns
t <sub>OHZ</sub> <sup>(2)</sup>	Output Disable to Output in High-Z	2	8	2	10	2	12	2	15	—	20	ns
t <sub>OH</sub>	Output Hold from Address Change	5	—	5	—	5	—	5	—	5	—	ns
<b>Write Cycle</b>												
t <sub>WC</sub>	Write Cycle Time	20	—	25	—	30	—	35	—	45	—	ns
t <sub>CW</sub>	Chip Select to End-of-Write	15	—	20	—	25	—	30	—	40	—	ns
t <sub>AW</sub>	Address Valid to End-of-Write	15	—	20	—	25	—	30	—	40	—	ns
t <sub>AS</sub>	Address Set-up Time	0	—	0	—	0	—	0	—	0	—	ns
t <sub>WP</sub>	Write Pulse Width	15	—	20	—	25	—	30	—	35	—	ns
t <sub>WR</sub>	Write Recovery Time	0	—	0	—	0	—	0	—	0	—	ns
t <sub>DW</sub>	Data to Write Time Overlap	11	—	13	—	14	—	15	—	20	—	ns
t <sub>WHZ</sub> <sup>(2)</sup>	Write Enable to Output in High-Z	—	10	—	11	—	15	—	15	—	20	ns
t <sub>DH</sub>	Data Hold from Write Time	0	—	0	—	0	—	0	—	0	—	ns
t <sub>OW</sub> <sup>(2)</sup>	Output Active from End-of-Write	5	—	5	—	5	—	5	—	5	—	ns

**NOTES:**

- 0° to +70°C temperature range only.
- This parameter guaranteed by device characterization, but is not production tested.
- 55° to +125°C temperature range only.

2946 tbl 11

**AC ELECTRICAL CHARACTERISTICS** (VCC = 5.0V ± 10%, All Temperature Ranges)

Symbol	Parameter	71256S55 <sup>(1)</sup>		71256S70 <sup>(1)</sup>		71256S85 <sup>(1)</sup>		71256S100 <sup>(1,3)</sup>		Unit
		71256L55 <sup>(1)</sup>		71256L70 <sup>(1)</sup>		71256L85 <sup>(1)</sup>		71256L100 <sup>(1,3)</sup>		
		Min.	Max.	Min.	Max.	Min.	Max.	Min.	Max.	
<b>Read Cycle</b>										
tRC	Read Cycle Time	55	—	70	—	85	—	100	—	ns
tAA	Address Access Time	—	55	—	70	—	85	—	100	ns
tACS	Chip Select Access Time	—	55	—	70	—	85	—	100	ns
tCLZ <sup>(2)</sup>	Chip Deselect to Output in Low-Z	5	—	5	—	5	—	5	—	ns
tCHZ <sup>(2)</sup>	Output Enable to Output in Low-Z	—	25	—	30	—	35	—	40	ns
tOE	Output Enable to Output Valid	—	25	—	30	—	35	—	40	ns
tOLZ <sup>(2)</sup>	Output Enable to Output in Low-Z	0	—	0	—	0	—	0	—	ns
tOHZ <sup>(2)</sup>	Output Disable to Output in High-Z	0	25	0	30	—	35	—	40	ns
tOH	Output Hold from Address Change	5	—	5	—	5	—	5	—	ns
<b>Write Cycle</b>										
tWC	Write Cycle Time	55	—	70	—	85	—	100	—	ns
tCW	Chip Select to End-of-Write	50	—	60	—	70	—	80	—	ns
tAW	Address Valid to End-of-Write	50	—	60	—	70	—	80	—	ns
tAS	Address Set-up Time	0	—	0	—	0	—	0	—	ns
tWP	Write Pulse Width	40	—	45	—	50	—	55	—	ns
tWR	Write Recovery Time	0	—	0	—	0	—	0	—	ns
tDW	Data to Write Time Overlap	25	—	30	—	35	—	40	—	ns
tDH	Data Hold from Write Time ( $\overline{WE}$ )	0	—	0	—	0	—	0	—	ns
tWHZ <sup>(2)</sup>	Write Enable to Output in High-Z	—	25	—	30	—	35	—	40	ns
tOW <sup>(2)</sup>	Output Active from End-of-Write	5	—	5	—	5	—	5	—	ns

**NOTES:**

1. -55°C to +125°C temperature range only.
2. This parameter guaranteed by device characterization, but is not production tested.
3. Also available: 120 and 150 ns military devices.

2946 tbl 11



**TIMING WAVEFORM OF READ CYCLE NO. 1<sup>(1)</sup>**

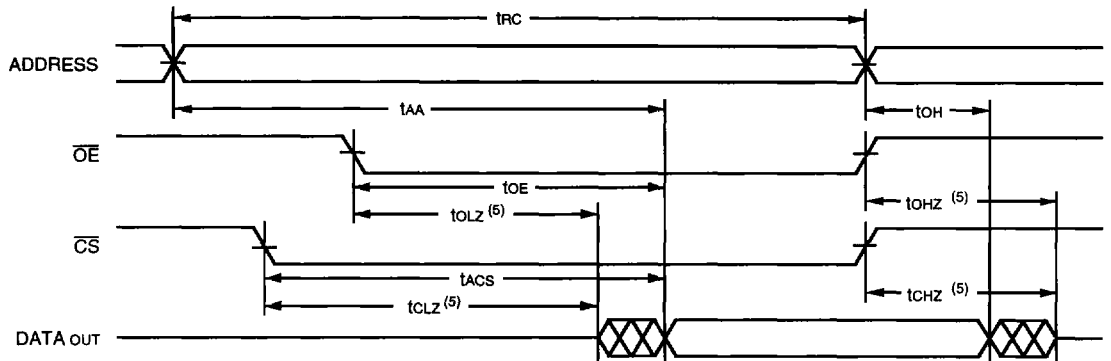

2946 drw 07

**TIMING WAVEFORM OF READ CYCLE NO. 2<sup>(1, 2, 4)</sup>**

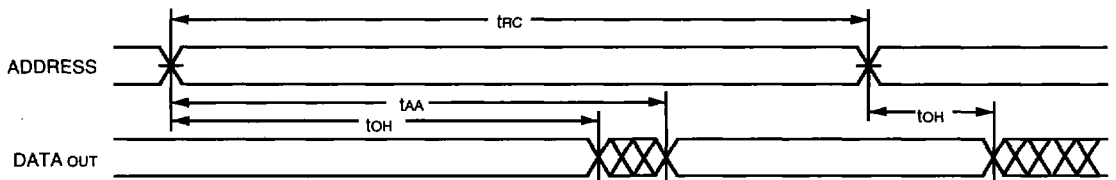

2946 drw 08

**TIMING WAVEFORM OF READ CYCLE NO. 3<sup>(1, 3, 4)</sup>**

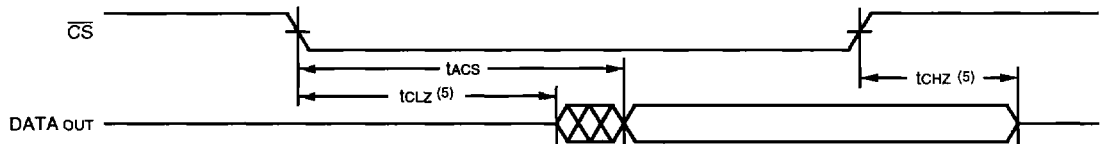

2946 drw 09

**NOTES:**

1. WE is HIGH for Read cycle.
2. Device is continuously selected, CS is LOW.
3. Address valid prior to or coincident with CS transition LOW.
4. OE is LOW.
5. Transition is measured ±200mV from steady state.

**TIMING WAVEFORM OF WRITE CYCLE NO. 1 ( $\overline{WE}$  CONTROLLED TIMING)<sup>(1, 2, 3, 5, 7)</sup>**

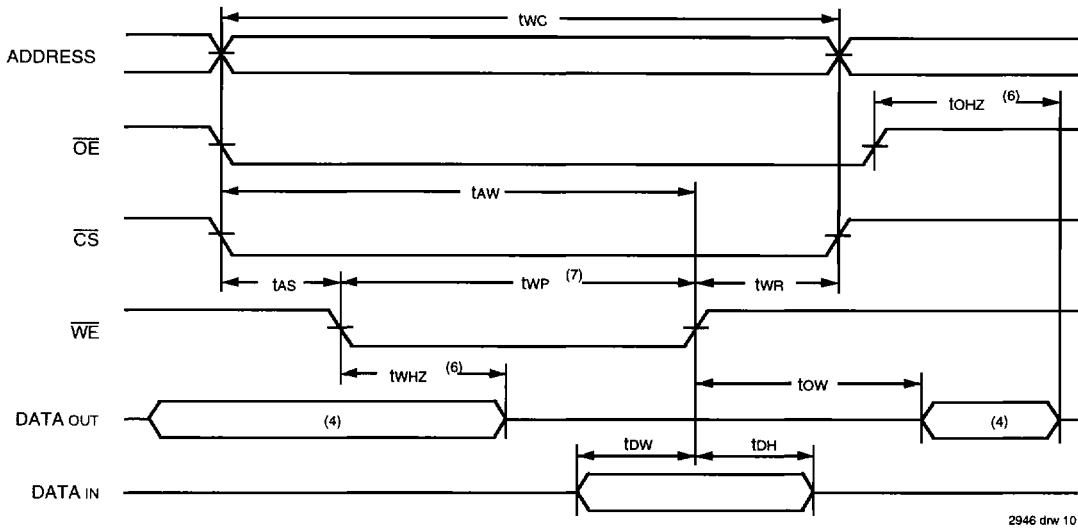

7

**TIMING WAVEFORM OF WRITE CYCLE NO. 2 ( $\overline{CS}$  CONTROLLED TIMING)<sup>(1, 2, 3, 5)</sup>**

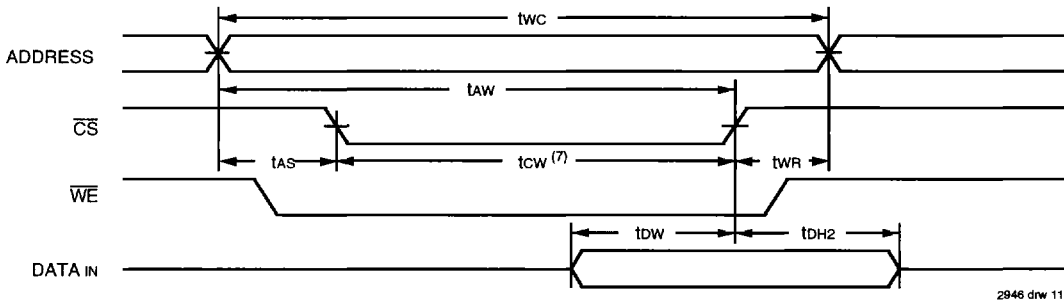

**NOTES:**

1.  $\overline{WE}$  or  $\overline{CS}$  must be HIGH during all address transitions.
2. A write occurs during the overlap of a LOW  $\overline{CS}$  and a LOW  $\overline{WE}$ .
3.  $t_{WR}$  is measured from the earlier of  $\overline{CS}$  or  $\overline{WE}$  going HIGH to the end of the write cycle.
4. During this period, I/O pins are in the output state so that the input signals must not be applied.
5. If the  $\overline{CS}$  LOW transition occurs simultaneously with or after the  $\overline{WE}$  LOW transition, the outputs remain in a high-impedance state.
6. Transition is measured  $\pm 200\text{mV}$  from steady state.
7. If  $\overline{OE}$  is LOW during a  $\overline{WE}$  controlled write cycle, the write pulse width must be the larger of  $t_{WP}$  or  $(t_{WHZ} + t_{OW})$  to allow the I/O drivers to turn off and data to be placed on the bus for the required  $t_{OW}$ . If  $\overline{OE}$  is HIGH during a  $\overline{WE}$  controlled write cycle, this requirement does not apply and the write pulse can be as short as the specified  $t_{WP}$ . For a  $\overline{CS}$  controlled write cycle,  $\overline{OE}$  may be LOW with no degradation to  $t_{cW}$ .



**ORDERING INFORMATION**

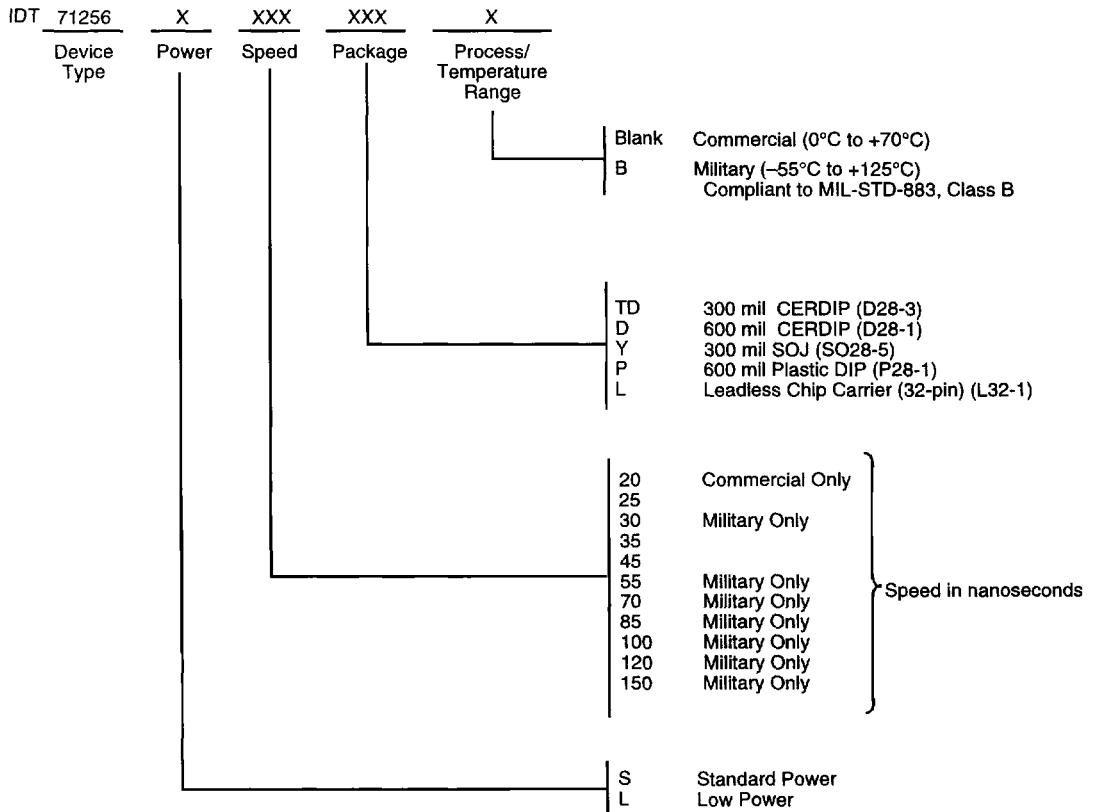

2846 drw 12