



128Kx8 MONOLITHIC SRAM, SMD 5962-96691

FEATURES

- Access Times 15, 17, 20, 25, 35, 45, 55ns
- Revolutionary, Center Power/Ground Pinout JEDEC Approved
 - 32 lead Ceramic SOJ (Package 101)
 - 36 lead Ceramic Flat Pack (Package 226)
- Evolutionary, Corner Power/Ground Pinout JEDEC Approved
 - 32 pin Ceramic DIP (Package 300)
 - 32 lead Ceramic SOJ (Package 101)
 - 32 lead Ceramic Flat Pack (Package 206)
- 32 pin, Rectangular Ceramic Leadless Chip Carrier (Package 601)
- MIL-STD-883 Compliant Devices Available
- Commercial, Industrial and Military Temperature Range
- 5 Volt Power Supply
- Low Power CMOS
- 2V Data Retention Devices Available (Low Power Version)
- TTL Compatible Inputs and Outputs

This product is subject to change without notice.

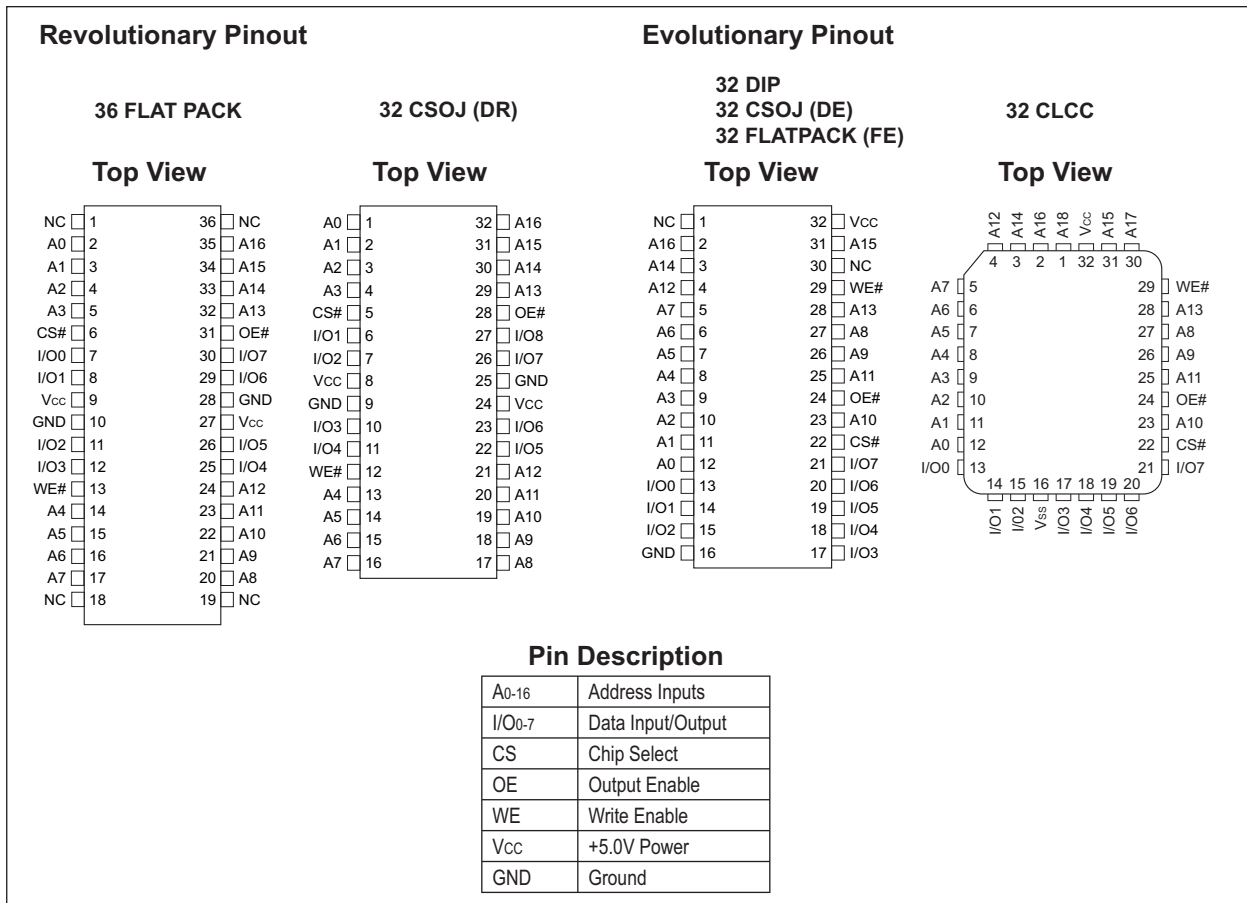



ABSOLUTE MAXIMUM RATINGS

Parameter	Symbol	Min	Max	Unit
Operating Temperature	T _A	-55	+125	°C
Storage Temperature	T _{STG}	-65	+150	°C
Signal Voltage Relative to GND	V _G	-0.5	V _{CC} +0.5	V
Junction Temperature	T _J		150	°C
Supply Voltage	V _{CC}	-0.5	7.0	V

TRUTH TABLE

CS#	OE#	WE#	Mode	Data I/O	Power
H	X	X	Standby	High Z	Standby
L	L	H	Read	Data Out	Active
L	X	L	Write	Data In	Active
L	H	H	Out Disable	High Z	Active

RECOMMENDED OPERATING CONDITIONS

Parameter	Symbol	Min	Max	Unit
Supply Voltage	V _{CC}	4.5	5.5	V
Input High Voltage	V _{IH}	2.2	V _{CC} + 0.3	V
Input Low Voltage	V _{IL}	-0.5	+0.8	V
Operating Temp. (Mil.)	T _A	-55	+125	°C

CAPACITANCE

T_A = +25°C

Parameter	Symbol	Condition	Package	Speed (ns)	Max	Unit
Input capacitance	C _{IN}	V _{IN} = 0V, f = 1.0MHz	32 Pin CSOJ, DIP, Flat Pack Evolutionary	15 to 55	20	pF
			36 Pin Flat Pack and 32 Pin CSOJ Revolutionary	15 to 25	12	pF
				35 to 55	20	pF
Output capacitance	C _{OUT}	V _{OUT} = 0V, f = 1.0MHz	32 Pin CSOJ, DIP, Flat Pack Evolutionary	15 to 55	20	pF
			36 Pin Flat Pack and 32 Pin CSOJ Revolutionary	15 to 55	12	pF
				35 to 55	20	pF
			32 Pin CLCC	15 to 55	15	pF

This parameter is guaranteed by design but not tested.

DC CHARACTERISTICS

V_{CC} = 5.0V, GND = 0V, -55°C ≤ T_A ≤ +125°C

Parameter	Symbol	Conditions	-15	-17	-20	-25	-35	-45	-55	Units
			Min Max	Min Max	Min Max	Min Max	Min Max	Min Max	Min Max	
Input Leakage Current	I _{LI}	V _{CC} = 5.5, V _{IN} = GND to V _{CC}	10	10	10	10	10	10	10	μA
Output Leakage Current	I _{LO}	CS# = V _{IH} , OE# = V _{IH} , V _{OUT} = GND to V _{CC}	10	10	10	10	10	10	10	μA
Operating Supply Current	I _{CC}	CS# = V _{IL} , OE# = V _{IH} , f = 5MHz, V _{CC} = 5.5	150	150	150	150	150	150	150	mA
Standby Current	I _{SB}	CS# = V _{IH} , OE# = V _{IH} , f = 5MHz, V _{CC} = 5.5	20	20	20	15	15	15	15	mA
Output Low Voltage	V _{OL}	I _{OL} = 2.1mA, V _{CC} = 4.5	0.4	0.4	0.4	0.4	0.4	0.4	0.4	V
Output High Voltage	V _{OH}	I _{OH} = -1.0mA, V _{CC} = 4.5	2.4	2.4	2.4	2.4	2.4	2.4	2.4	V

NOTE: DC test conditions: V_{IH} = V_{CC} - 0.3V, V_{IL} = 0.3V



AC CHARACTERISTICS

V_{CC} = 5.0V, GND = 0V, -55°C ≤ T_A ≤ 125°C

Parameter Read Cycle	Symbol	-15		-17		-20		-25		-35		-45		-55		Unit
		Min	Max	Min	Max	Min	Max	Min	Max	Min	Max	Min	Max	Min	Max	
Read Cycle Time	t _{RC}	15		17		20		25		35		45		55		ns
Address Access Time	t _{AA}		15		17		20		25		35		45		55	ns
Output Hold from Address Change	t _{OH}	0		0		0		0		0		0		0		ns
Chip Select Access Time	t _{ACS}		15		17		20		25		35		45		55	ns
Output Enable to Output Valid	t _{OE}		10		10		12		15		20		25		30	ns
Chip Select to Output in Low Z	t _{CLZ} ¹	3		3		3		3		3		3		3		ns
Output Enable to Output in Low Z	t _{OLZ} ¹	0		0		0		0		0		0		0		ns
Chip Disable to Output in High Z	t _{CHZ} ¹		10		10		10		12		20		20		20	ns
Output Disable to Output in High Z	t _{OHZ} ¹		10		10		10		12		20		20		20	ns

1. This parameter is guaranteed by design but not tested.

AC CHARACTERISTICS

V_{CC} = 5.0V, GND = 0V, -55°C ≤ T_A ≤ 125°C

Parameter Write Cycle	Symbol	-15		-17		-20		-25		-35		-45		-55		Unit
		Min	Max	Min	Max	Min	Max	Min	Max	Min	Max	Min	Max	Min	Max	
Write Cycle Time	t _{WC}	15		17		20		25		35		45		55		ns
Chip Select to End of Write	t _{CW}	14		14		15		20		25		30		45		ns
Address Valid to End of Write	t _{AW}	14		15		15		20		25		30		45		ns
Data Valid to End of Write	t _{DW}	10		10		12		15		20		25		25		ns
Write Pulse Width	t _{WP}	14		14		15		20		25		30		45		ns
Address Setup Time	t _{AS}	0		0		0		0		0		0		0		ns
Address Hold Time	t _{AH}	0		0		0		0		0		0		0		ns
Output Active from End of Write	t _{OW} ¹	3		3		3		3		4		4		4		ns
Write Enable to Output in High Z	t _{WHZ} ¹		10		10		12		15		20		25		25	ns
Data Hold Time	t _{DH}	0		0		0		0		0		0		0		ns

1. This parameter is guaranteed by design but not tested.

AC TEST CIRCUIT

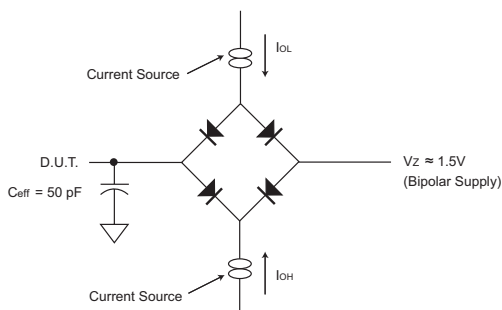

AC TEST CONDITIONS

Parameter	Typ	Unit
Input Pulse Levels	V _{IL} = 0, V _{IH} = 3.0	V
Input Rise and Fall	5	ns
Input and Output Reference Level	1.5	V
Output Timing Reference Level	1.5	V

Notes:
V_Z is programmable from -2V to +7V.
I_{OL} & I_{OH} programmable from 0 to 16mA.
Tester Impedance Z₀ = 75Ω.
V_Z is typically the midpoint of V_{OH} and V_{OL}.
I_{OL} & I_{OH} are adjusted to simulate a typical resistive load circuit.
ATE tester includes jig capacitance.



TIMING WAVEFORM – READ CYCLE

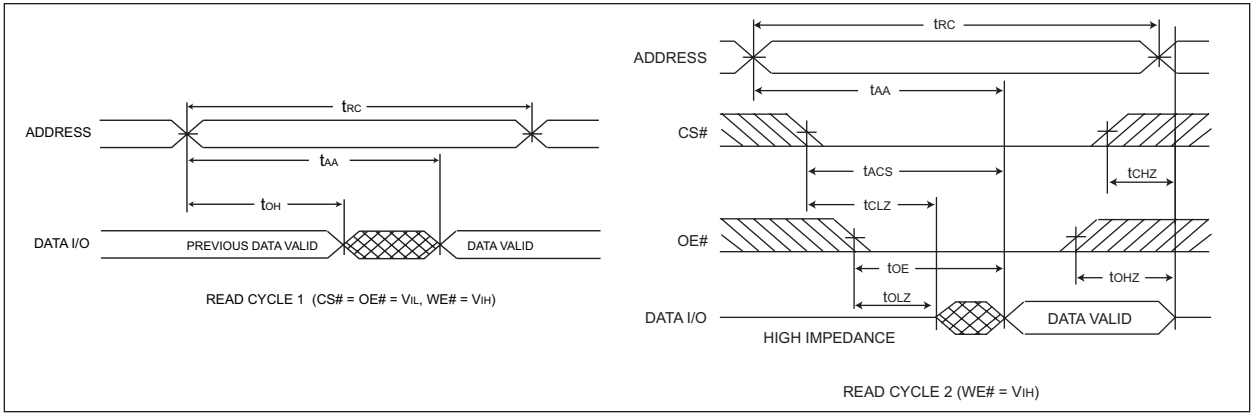

WRITE CYCLE – WE# CONTROLLED

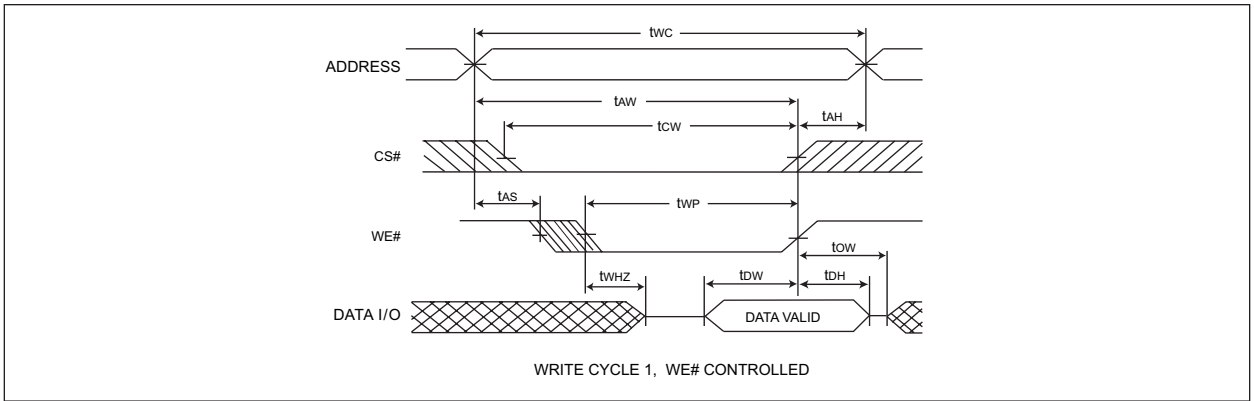

WRITE CYCLE – CS# CONTROLLED

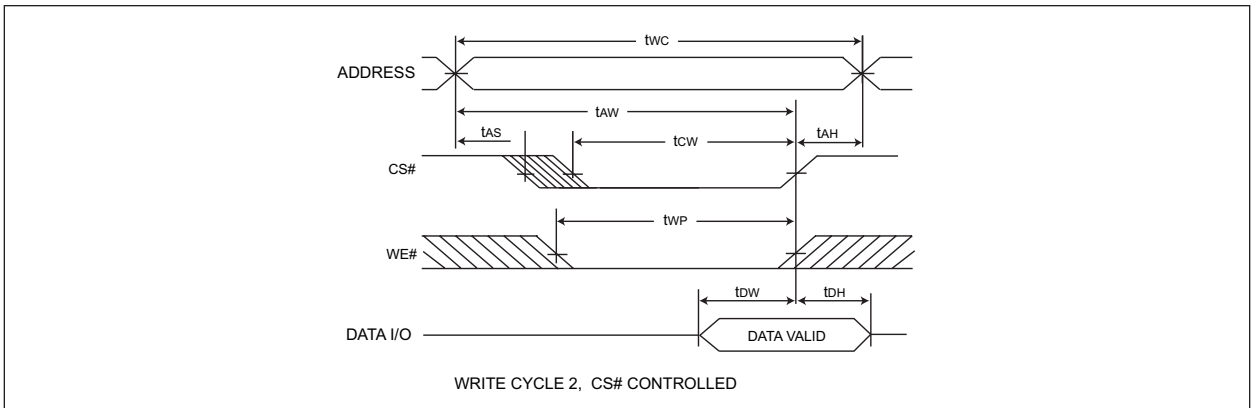



PACKAGE 101: 32 LEAD, CERAMIC SOJ

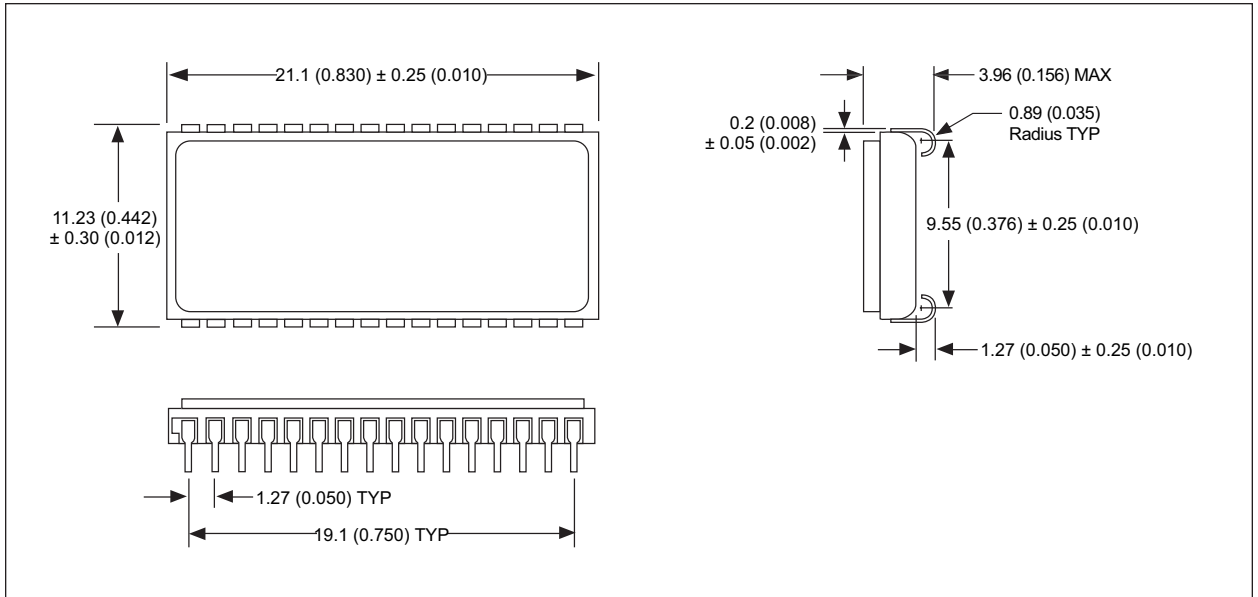

ALL LINEAR DIMENSIONS ARE MILLIMETERS AND PARENTHETICALLY IN INCHES



PACKAGE 206: 32 LEAD, CERAMIC FLAT PACK

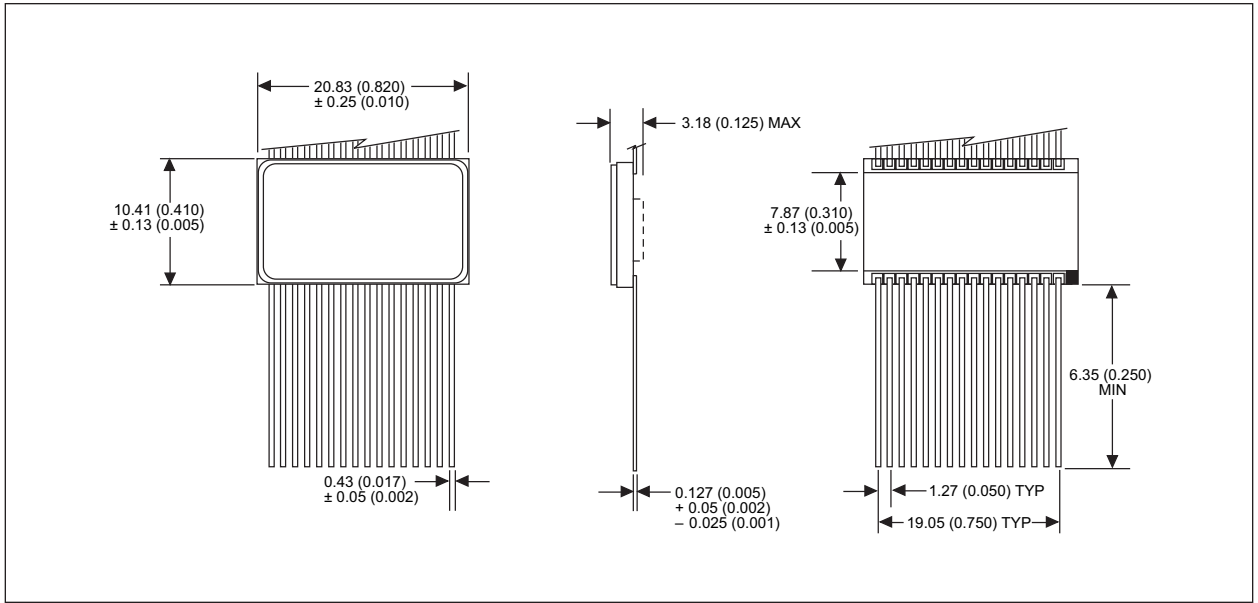

ALL LINEAR DIMENSIONS ARE MILLIMETERS AND PARENTHETICALLY IN INCHES

PACKAGE 226: 36 LEAD, CERAMIC FLAT PACK

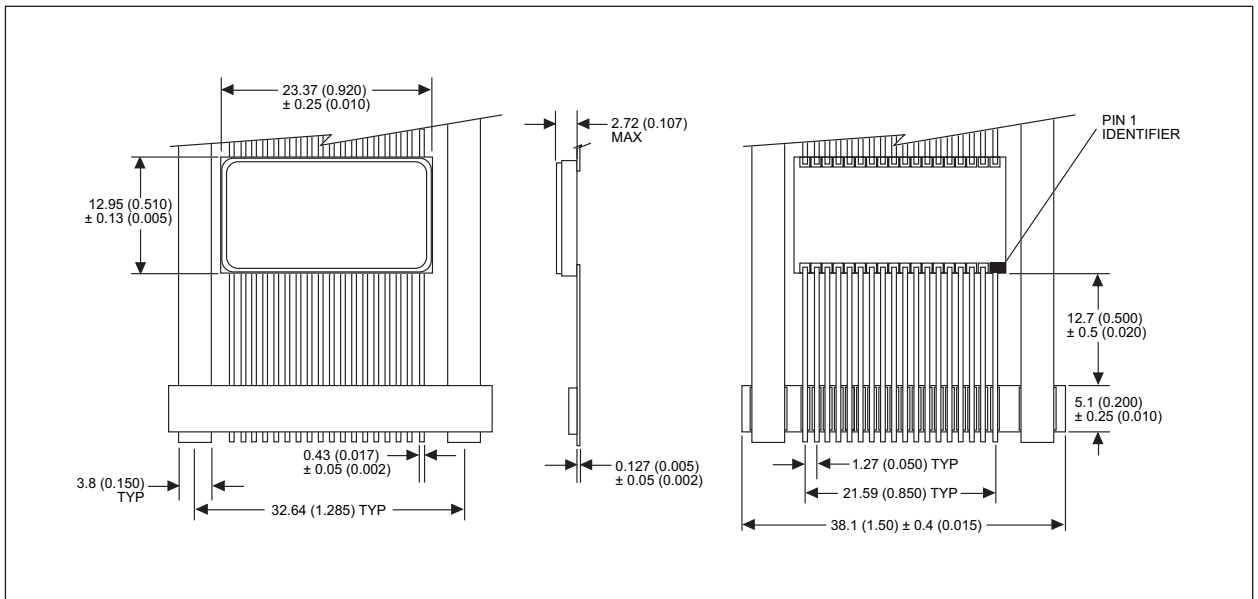

ALL LINEAR DIMENSIONS ARE MILLIMETERS AND PARENTHETICALLY IN INCHES

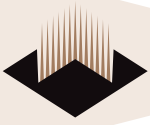

PACKAGE 300: 32 PIN, CERAMIC DIP, SINGLE CAVITY SIDE BRAZED

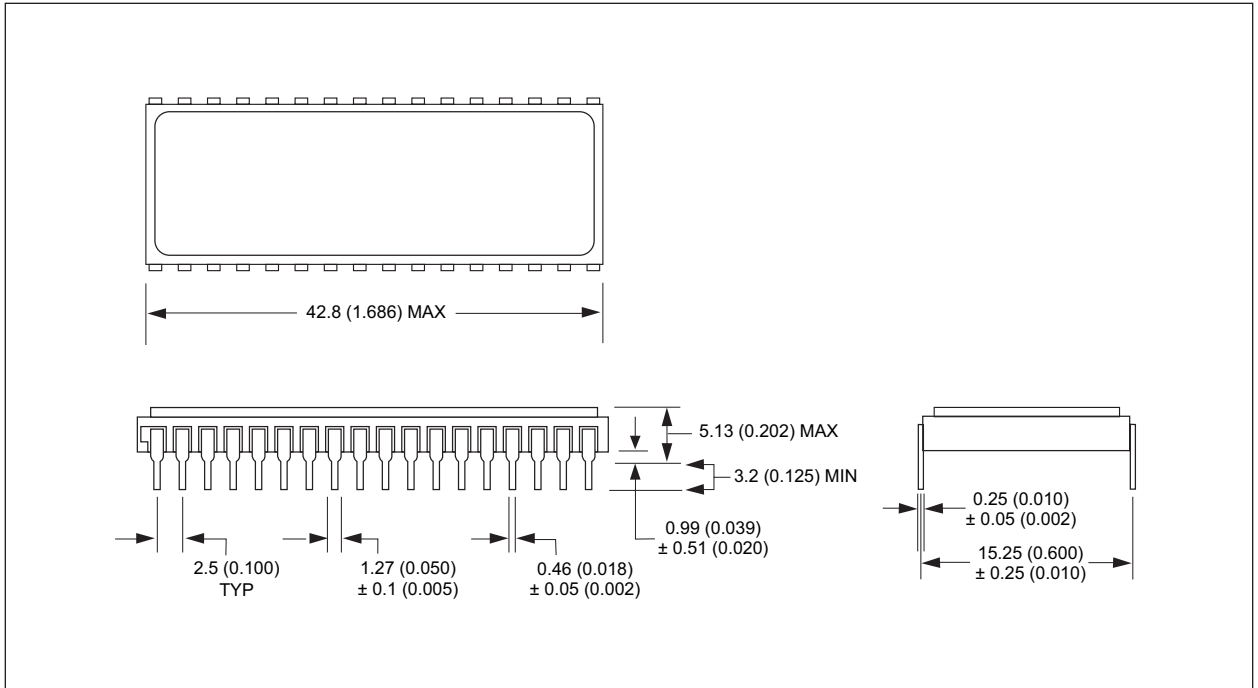

ALL LINEAR DIMENSIONS ARE MILLIMETERS AND PARENTHETICALLY IN INCHES



PACKAGE 601: 32 PIN, RECTANGULAR CERAMIC LEADLESS CHIP CARRIER

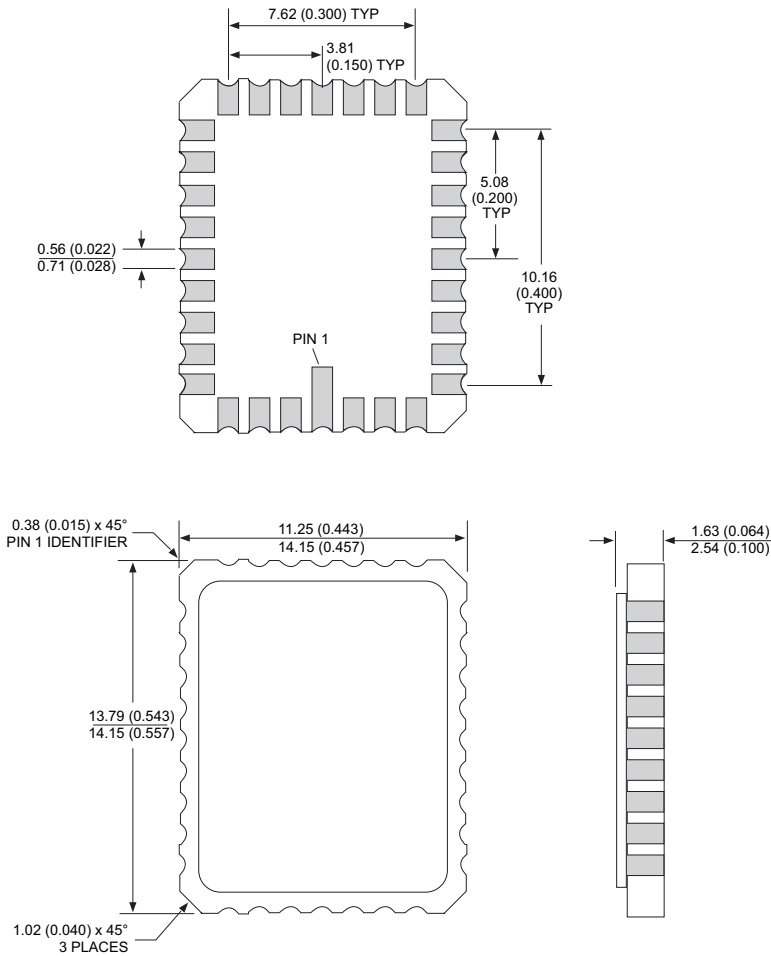

ALL LINEAR DIMENSIONS ARE MILLIMETERS AND PARENTHETICALLY IN INCHES



DATA RETENTION CHARACTERISTICS

-55°C ≤ T_A ≤ +125°C
Low Power L Version Only

Parameter	Symbol	Conditions	Min	Max	Units
Data Retention Supply Voltage	V _{DR}	CS# ≥ V _{CC} - 0.2V	2.0	5.5	V
Data Retention Current	I _{CCDR3}	V _{CC} = 2V		400	μA

ORDERING INFORMATION

W M S 128K8 X - XXX X X X

LEAD FINISH:

- Blank = Gold plated leads
- A = Solder dip leads

DEVICE GRADE:

- M = Military Screened -55°C to +125°C
- I = Industrial -40°C to +85°C
- C = Commercial 0°C to +70°C

PACKAGE:

- C = 32 Pin Ceramic .600" DIP (Package 300)
- CL = 32 Pin Rectangular Ceramic Leadless Chip Carrier (Package 601)
- DE = 32 Lead Ceramic SOJ (Package 101) Evolutionary
- DR = 32 Lead Ceramic SOJ (Package 101) Revolutionary
- F = 36 Lead Ceramic Flat Pack (Package 226)
- FE = 32 Lead Ceramic Flat Pack (Package 220)

ACCESS TIME (ns)

IMPROVEMENT MARK

- L = Low Power for 2V Data Retention

ORGANIZATION, 128K x 8

SRAM

MONOLITHIC

WHITE ELECTRONIC DESIGNS CORP.

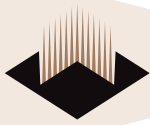

Device Type	Speed	Package	SMD No.
128K x 8 SRAM Monolithic	55ns	32 lead SOJ Revol (DR)	5962-96691 05HUX
128K x 8 SRAM Monolithic	45ns	32 lead SOJ Revol (DR)	5962-96691 06HUX
128K x 8 SRAM Monolithic	35ns	32 lead SOJ Revol (DR)	5962-96691 07HUX
128K x 8 SRAM Monolithic	25ns	32 lead SOJ Revol (DR)	5962-96691 08HUX
128K x 8 SRAM Monolithic	20ns	32 lead SOJ Revol (DR)	5962-96691 09HUX
128K x 8 SRAM Monolithic	17ns	32 lead SOJ Revol (DR)	5962-96691 10HUX
128K x 8 SRAM Monolithic	15ns	32 lead SOJ Revol (DR)	5962-96691 11HUX
128K x 8 SRAM Monolithic	55ns	32 lead SOJ Evol (DE)	5962-96691 05HTX
128K x 8 SRAM Monolithic	45ns	32 lead SOJ Evol (DE)	5962-96691 06HTX
128K x 8 SRAM Monolithic	35ns	32 lead SOJ Evol (DE)	5962-96691 07HTX
128K x 8 SRAM Monolithic	25ns	32 lead SOJ Evol (DE)	5962-96691 08HTX
128K x 8 SRAM Monolithic	20ns	32 lead SOJ Evol (DE)	5962-96691 09HTX
128K x 8 SRAM Monolithic	17ns	32 lead SOJ Evol (DE)	5962-96691 10HTX
128K x 8 SRAM Monolithic	15ns	32 lead SOJ Evol (DE)	5962-96691 11HTX
128K x 8 SRAM Monolithic	55ns	32 pin DIP (C)	5962-96691 05HYX
128K x 8 SRAM Monolithic	45ns	32 pin DIP (C)	5962-96691 06HYX
128K x 8 SRAM Monolithic	35ns	32 pin DIP (C)	5962-96691 07HYX
128K x 8 SRAM Monolithic	25ns	32 pin DIP (C)	5962-96691 08HYX
128K x 8 SRAM Monolithic	20ns	32 pin DIP (C)	5962-96691 09HYX
128K x 8 SRAM Monolithic	17ns	32 pin DIP (C)	5962-96691 10HYX
128K x 8 SRAM Monolithic	15ns	32 pin DIP (C)	5962-96691 11HYX
128K x 8 SRAM Monolithic	55ns	36 pin Flatpack (F)	5962-96691 05HXX
128K x 8 SRAM Monolithic	45ns	36 pin Flatpack (F)	5962-96691 06HXX
128K x 8 SRAM Monolithic	35ns	36 pin Flatpack (F)	5962-96691 07HXX
128K x 8 SRAM Monolithic	25ns	36 pin Flatpack (F)	5962-96691 08HXX
128K x 8 SRAM Monolithic	20ns	36 pin Flatpack (F)	5962-96691 09HXX
128K x 8 SRAM Monolithic	17ns	36 pin Flatpack (F)	5962-96691 10HXX
128K x 8 SRAM Monolithic	15ns	36 pin Flatpack (F)	5962-96691 11HXX