







SPRAGUE OPTOELECTRONIC DEVICES

T-41-21

DISCRETE LIGHT SOURCES, continued

Package Outline	Q-Line Stock No.	Sprague Cat. No.	Emission Color	Luminous Intensity (mcd)	Forward Current (mA)	Material/Wavelength (nm)	Lens Configuration	Mounting Hardware
 Fig. 9	QLP-1214-01	ED123G	Green	0.7	10	GaP/555	Green Clear	none
	QLP-1216-01	ED124G	Green	0.4	10	GaP/555	Green Diffused	
	QLP-1210-01	ED123R	Red	1.5	10	GaP/700	Red Clear	
	QLP-1212-01	ED124R	Red	1.0	10	GaP/700	Red Diffused	
	QLP-1218-01	ED123Y	Yellow	2.0	10	GaAsP on GaP/585	Yellow Clear	
	QLP-1220-01	ED124Y	Yellow	1.0	10	GaAsP on GaP/585	Yellow Diffused	
 Fig. 10	QLP-1168-01	ED102GKB	Green	0.45	15	GaP/560	Green Diffused	Part of device
	QLP-1170-01	ED102GKW	Green	0.45	15	GaP/560	Green Diffused	
	QLP-1162-01	ED108GKB	Green	2.5	15	GaP/560	Green Clear	
	QLP-1164-01	ED108GKW	Green	2.5	15	GaP/560	Green Clear	
	QLP-1154-01	ED102RKB	Red	0.5	10	GaP/700	Red Diffused	
	QLP-1156-01	ED102RKB	Red	0.5	10	GaP/700	Red Diffused	
	QLP-1150-01	ED108RKB	Red	0.7	10	GaP/700	Transparent Clear	
	QLP-1152-01	ED108RKB	Red	0.7	10	GaP/700	Transparent Clear	
	QLP-1158-01	ED109RKB	Red	0.6	10	GaP/700	Milk White Diffused	
	QLP-1160-01	ED108RKB	Red	0.6	10	GaP/700	Milk White Diffused	
 Fig. 11	QLP-1138-01	ED102G	Green	0.45	15	GaP/560	Green Diffused	none
	QLP-1136-01	ED108G	Green	2.5	15	GaP/560	Green Clear	
	QLP-1132-01	ED102R	Red	0.5	10	GaP/700	Red Diffused	
	QLP-1130-01	ED108R	Red	0.7	10	GaP/700	Transparent Clear	
 Fig. 12	QLP-1116-01	ED121G	Green	3.0	20	GaP/560	Transparent Clear	none
	QLP-1118-01	ED122G	Green	2.0	20	GaP/560	Green Clear	
	QLP-1110-01	ED121R	Red	0.7	10	GaP/700	Transparent Clear	
	QLP-1112-01	ED122R	Red	0.6	10	GaP/700	Red Clear	
 Fig. 13	QLP-1182-01	ED202G	Green	0.1	15	GaP/560	Transparent Clear	none
	QLP-1180-01	ED202R	Red	0.5	10	GaP/700	Transparent Clear	
 Fig. 14	QLP-1266-01	QLB-1266	Red	3.0	35 Max	GaP/697	Red Clear	part of device
	QLP-1267-01	QLB-1267	Green	3.0	35 Max	GaP/565	Green Clear	
 Fig. 15	QLP-1176-01	ED101RG	Red/Green	0.6	20	GaP/700, GaP/560	Milk White Diffused	none

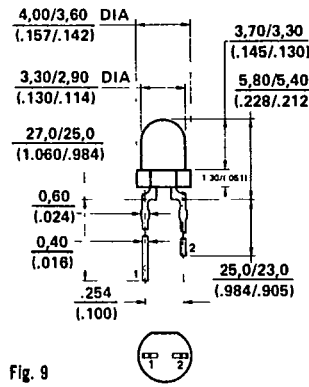

Fig. 9

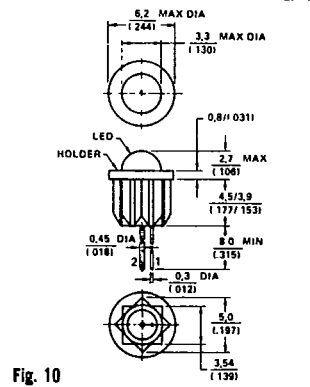

Fig. 10

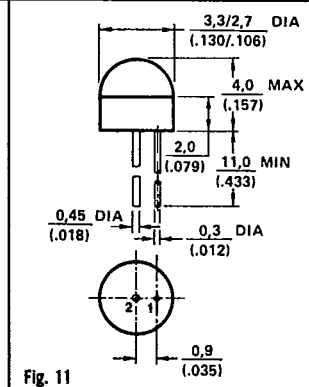

Fig. 11

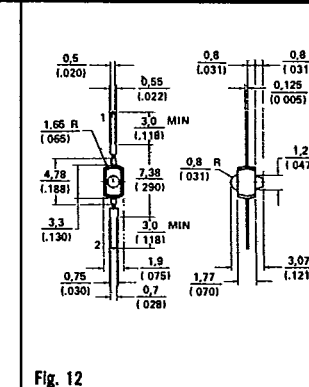

Fig. 12

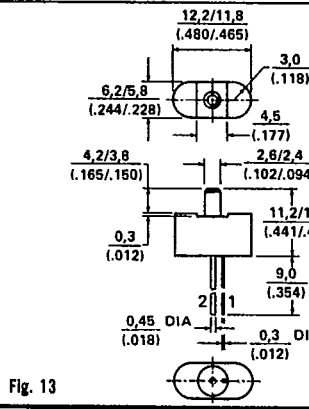

Fig. 13

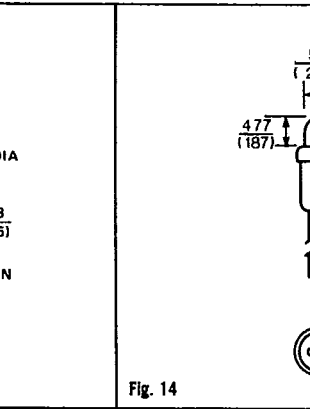

Fig. 14

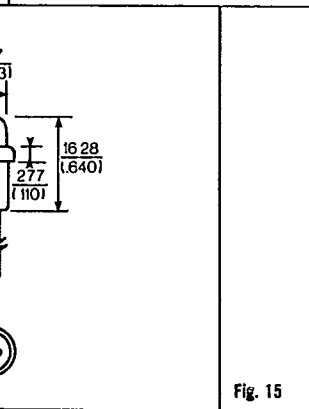

Fig. 15

Note: PIN 1 is the anode, PIN 2 is the cathode. Dimensions: mm (inches)