

- Single Power Supply Supports 2.7-V and 3.6-V Read/Write Operation
- Organization . . . 1048576 By 8 Bits
- Array Blocking Architecture
  - One 16K-Byte Boot Sector
  - Two 8K-Byte Parameter Sectors
  - One 32K-Byte Sector
  - Fifteen 64K-Byte Sectors
  - Any Combination of Sectors Can Be Erased. Supports Full-Chip Erase
  - Any Combination of Sectors Can Be Marked as Read-Only
- Boot-Code Sector Architecture
  - T = Top Sector
  - B = Bottom Sector
- Sector Protection
  - Hardware Protection Method That Disables Any Combination of Sectors From Write or Erase Operations Using Standard Programming Equipment
- Embedded Program/Erase Algorithms
  - Automatically Pre-Programs and Erases Any Sector
  - Automatically Programs and Verifies the Program Data at Specified Address
- JEDEC Standards
  - Compatible With JEDEC Byte Pinouts
  - Compatible With JEDEC EEPROM Command Set
- Fully Automated On-Chip Erase and Program Operations
- 100 000 Program/Erase Cycles
- Low Power Dissipation
- Low Current Consumption
  - 20-mA Typical Active Read for Byte Mode
  - 30-mA Typical Program/Erase Current
  - Less Than 60- $\mu$ A Standby Current
  - 5  $\mu$ A in Deep Power-Down Mode
- All Inputs/Outputs TTL-Compatible
- Erase Suspend/Resume
  - Supports Reading Data From, or Programming Data to, a Sector Not Being Erased
- Hardware-Reset Pin Initializes the Internal-State Machine to the Read Operation
- 40-Pin Thin Small-Outline Package (TSOP) (DCD Suffix)
- Detection Of Program/Erase Operation
  - Data Polling and Toggle Bit Feature of Program/Erase Cycle Completion
  - Hardware Method for Detection of Program/Erase Cycle Completion Through Ready/Busy (RY/ $\overline$ BY) Output Pin
- High-Speed Data Access at 3.3-V  $V_{CC} \pm 10\%$  at Three Temperature Ranges
  - 90 ns      Commercial . . . 0°C to 70°C
  - 100 ns     Extended . . . –40°C to 85°C
  - 120 ns     Automotive . . . –40°C to 125°C

PIN NOMENCLATURE	
A[0:19]	Address Inputs
DQ[0:7]	Data In/Data out
$\overline$ CE	Chip Enable
$\overline$ OE	Output Enable
NC	No Internal Connection
$\overline$ RESET	Reset/Deep Power Down
RY/ $\overline$ BY	Ready/Busy Output
$V_{CC}$	Power Supply
$V_{SS}$	Ground
$\overline$ WE	Write Enable

PRODUCT PREVIEW



Please be aware that an important notice concerning availability, standard warranty, and use in critical applications of Texas Instruments semiconductor products and disclaimers thereto appears at the end of this data sheet.

PRODUCT PREVIEW information concerns products in the formative or design phase of development. Characteristic data and other specifications are design goals. Texas Instruments reserves the right to change or discontinue these products without notice.



**TMS29LF008T, TMS29LF008B**  
**1048576 BY 8-BIT**  
**FLASH MEMORIES**

SMJS846A – MAY 1997 – REVISED NOVEMBER 1997

**40-PIN TSOP  
DCD PACKAGE  
(TOP VIEW)**



**PRODUCT PREVIEW**

**description**

The TMS29LF008T/B is an 1048576 by 8-bit (8388608-bit), 3-V single-supply, programmable read-only memory device that can be electrically erased and reprogrammed. This device is organized as 1024K by 8 bits, divided into 19 sectors:

- One 16K-byte boot sector
- Two 8K-byte sectors
- One 32K-byte sector
- Fifteen 64K-byte sectors

Any combination of sectors can be marked as read-only or erased. Full-chip erasure is also supported.

Sector data protection is afforded by methods that can disable any combination of sectors from write or read operations using standard programming equipment. An on-chip state machine controls the program and erase operations by providing an on-board algorithm that automatically pre-programs and erases any sector before it automatically programs and verifies program data at any specified address. The command set is compatible with that of the Joint Electronic Device Engineering Council (JEDEC) standards and is compatible with the JEDEC 8M-bit electrically erasable, programmable read-only memory (EEPROM) command set. A suspend/resume feature allows access to unaltered memory blocks during a section-erase operation. All outputs of this device are TTL-compatible. Additionally, an erase/suspend/resume feature supports reading data from, or programming data to, a sector that is not being erased.



**description (continued)**

Device operations are selected by writing JEDEC-standard commands into the command register using standard microprocessor write timings. The command register acts as an input to an internal-state machine which interprets the commands, controls the erase and programming operations, outputs the status of the device, outputs the data stored in the device, and outputs the device algorithm-selection code. On initial power up, the device defaults to the read mode. A hardware-reset pin initializes the internal-state machine to the read operation.

The device has low power dissipation with a 20-mA active read for the byte mode, 30-mA typical program/erase current mode, and less than 60-µA standby current with a 5-µA deep-power-down mode. These devices are offered with 90-, 100-, and 120-ns access times. Table 1 and Table 2 show the sector-address ranges. The TMS29LF008T/B is offered in a 40-pin thin small-outline package (TSOP) (DCD suffix).

**device symbol nomenclature**

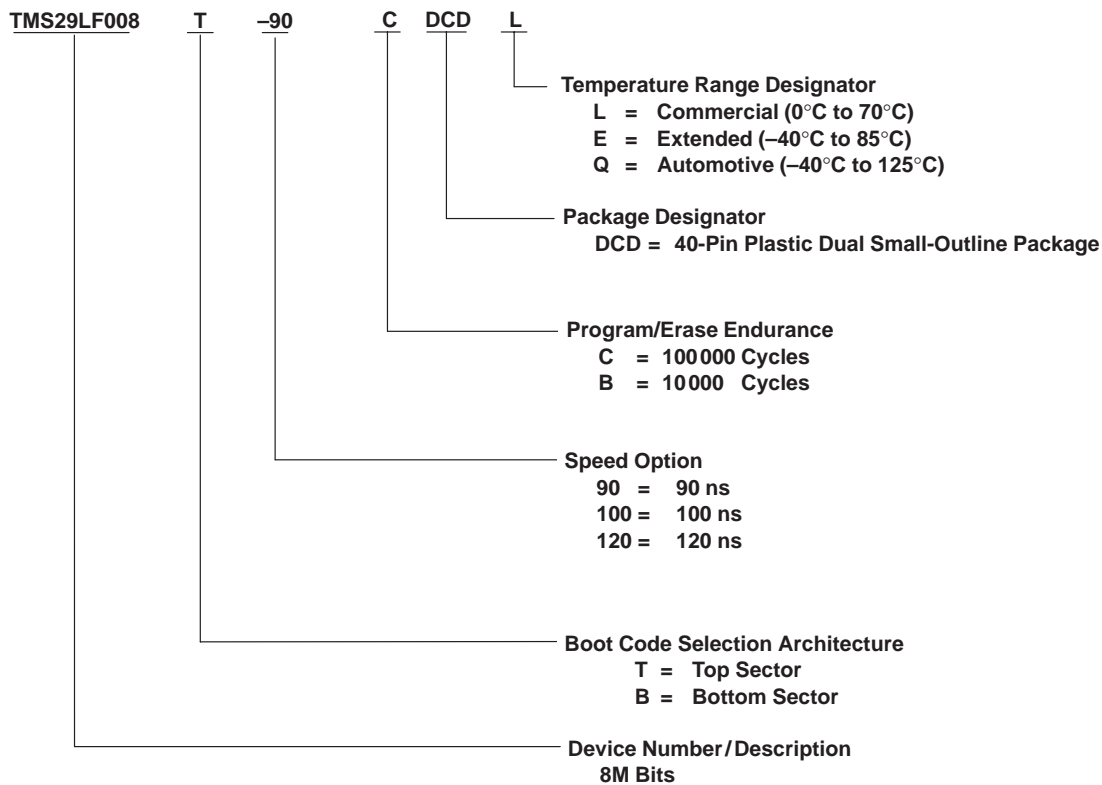

PRODUCT PREVIEW



TMS29LF008T, TMS29LF008B  
 1048576 BY 8-BIT  
 FLASH MEMORIES

SMJS846A – MAY 1997 – REVISED NOVEMBER 1997

logic symbol†

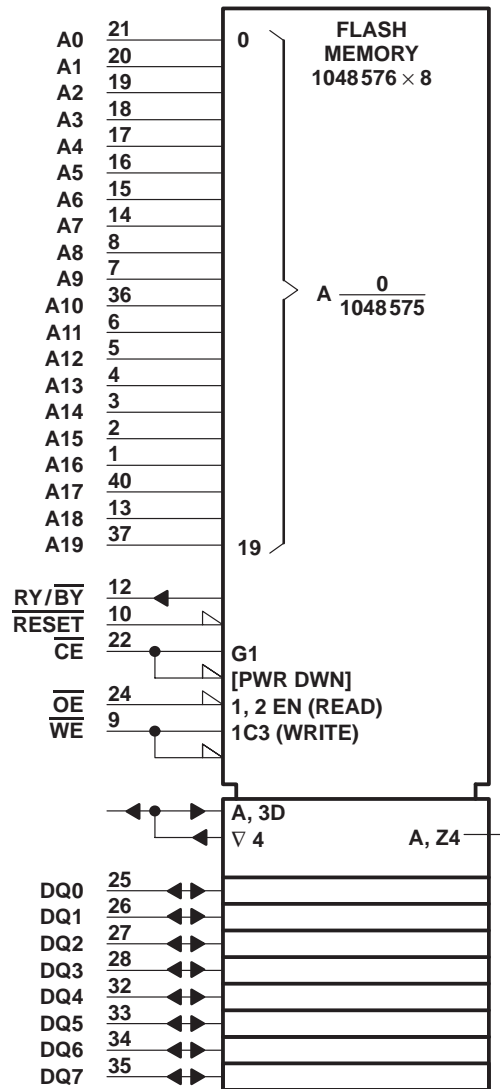

† This symbol is in accordance with ANSI/IEEE Std 91-1984 and IEC Publication 617-12.

PRODUCT PREVIEW



block diagram

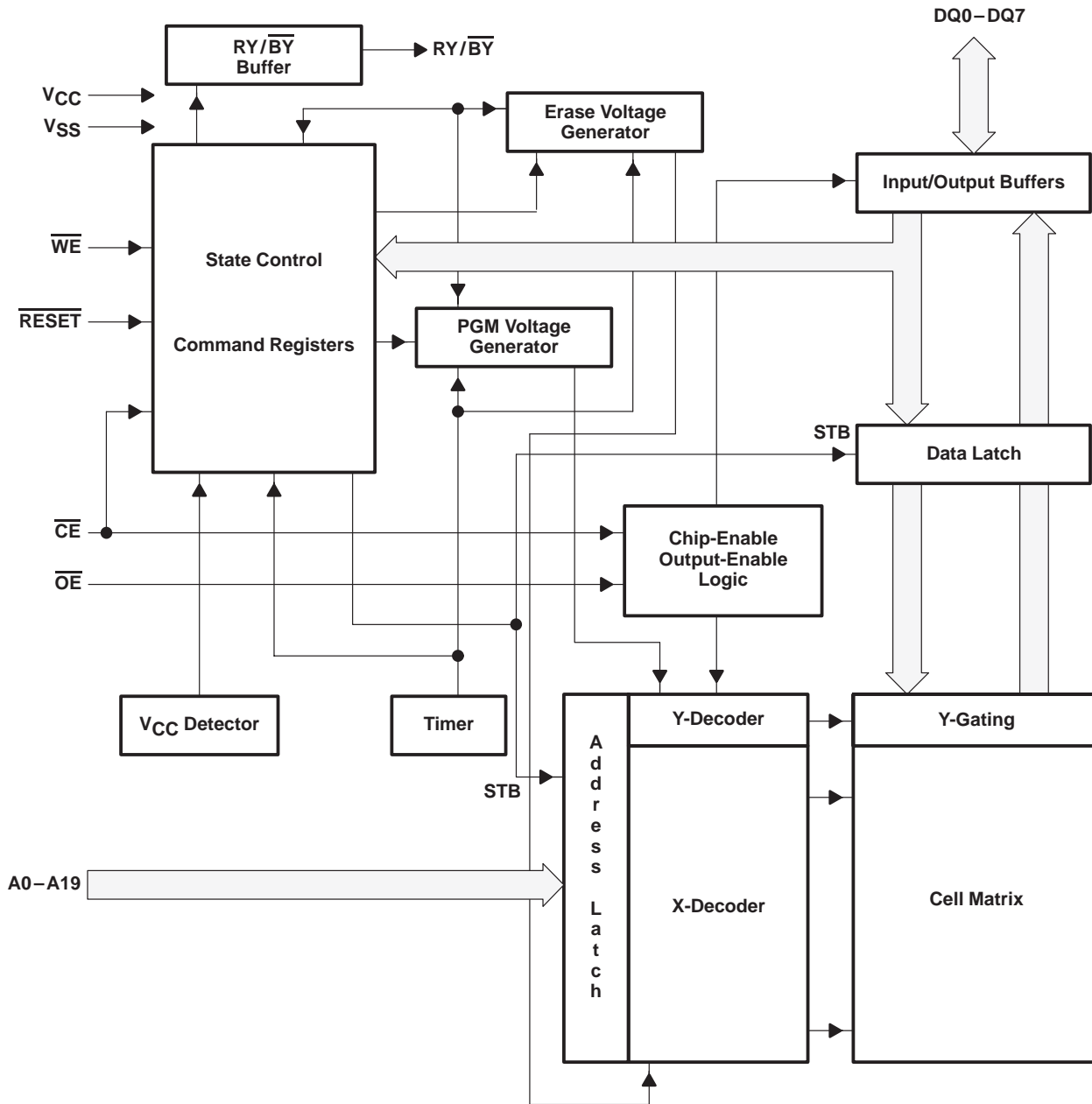

PRODUCT PREVIEW

**TMS29LF008T, TMS29LF008B**  
**1048576 BY 8-BIT**  
**FLASH MEMORIES**

SMJS846A – MAY 1997 – REVISED NOVEMBER 1997

**operation**

See Table 1 and Table 2 for the sector-address ranges of the TMS29LF008T/B.

**Table 1. Top-Boot Sector-Address Ranges†**

	A19	A18	A17	A16	A15	A14	A13	SECTOR SIZE	ADDRESS RANGE
SA18	1	1	1	1	1	1	X	16K-Byte	FC000H–FFFFFFH
SA17	1	1	1	1	1	0	1	8K-Byte	FA000H–FBFFFH
SA16	1	1	1	1	1	0	0	8K-Byte	F8000H–F9FFFH
SA15	1	1	1	1	0	X	X	32K-Byte	F0000H–F7FFFH
SA14	1	1	1	0	X	X	X	64K-Byte	E0000H–EFFFFH
SA13	1	1	0	1	X	X	X	64K-Byte	D0000H–DFFFFH
SA12	1	1	0	0	X	X	X	64K-Byte	C0000H–CFFFFH
SA11	1	0	1	1	X	X	X	64K-Byte	B0000H–BFFFFH
SA10	1	0	1	0	X	X	X	64K-Byte	A0000H–AFFFFH
SA9	1	0	0	1	X	X	X	64K-Byte	90000H–9FFFFH
SA8	1	0	0	0	X	X	X	64K-Byte	80000H–8FFFFH
SA7	0	1	1	1	X	X	X	64K-Byte	70000H–7FFFFH
SA6	0	1	1	0	X	X	X	64K-Byte	60000H–6FFFFH
SA5	0	1	0	1	X	X	X	64K-Byte	50000H–5FFFFH
SA4	0	1	0	0	X	X	X	64K-Byte	40000H–4FFFFH
SA3	0	0	1	1	X	X	X	64K-Byte	30000H–3FFFFH
SA2	0	0	1	0	X	X	X	64K-Byte	20000H–2FFFFH
SA1	0	0	0	1	X	X	X	64K-Byte	10000H–1FFFFH
SA0	0	0	0	0	X	X	X	64K-Byte	00000H–0FFFFH

† The address range is A0–A19.

PRODUCT PREVIEW



operation (continued)

Table 2. Bottom-Boot Sector-Address Ranges†

	A19	A18	A17	A16	A15	A14	A13	SECTOR SIZE	ADDRESS RANGE
SA18	1	1	1	1	X	X	X	64K-Byte	F0000H–FFFFFH
SA17	1	1	1	0	X	X	X	64K-Byte	E0000H–EFFFFH
SA16	1	1	0	1	X	X	X	64K-Byte	D0000H–DFFFFH
SA15	1	1	0	0	X	X	X	64K-Byte	C0000H–CFFFFH
SA14	1	0	1	1	X	X	X	64K-Byte	B0000H–BFFFFH
SA13	1	0	1	0	X	X	X	64K-Byte	A0000H–AFFFFH
SA12	1	0	0	1	X	X	X	64K-Byte	90000H–9FFFFH
SA11	1	0	0	0	X	X	X	64K-Byte	80000H–8FFFFH
SA10	0	1	1	1	X	X	X	64K-Byte	70000H–7FFFFH
SA9	0	1	1	0	X	X	X	64K-Byte	60000H–6FFFFH
SA8	0	1	0	1	X	X	X	64K-Byte	50000H–5FFFFH
SA7	0	1	0	0	X	X	X	64K-Byte	40000H–4FFFFH
SA6	0	0	1	1	X	X	X	64K-Byte	30000H–3FFFFH
SA5	0	0	1	0	X	X	X	64K-Byte	20000H–2FFFFH
SA4	0	0	0	1	X	X	X	64K-Byte	10000H–1FFFFH
SA3	0	0	0	0	1	X	X	32K-Byte	08000H–0FFFFH
SA2	0	0	0	0	0	1	1	8K-Byte	06000H–07FFFH
SA1	0	0	0	0	0	1	0	8K-Byte	04000H–05FFFH
SA0	0	0	0	0	0	0	X	16K-Byte	00000H–03FFFH

† The address range is A0–A19.

See Table 3 for the operation modes of the TMS29LF008T/B.

Table 3. Operation Modes

MODE	FUNCTIONS‡									DQ0–DQ7
	$\overline{\text{CE}}$	$\overline{\text{OE}}$	$\overline{\text{WE}}$	A0	A1	A6	A9	$\overline{\text{RESET}}$		
Algorithm-selection mode	V <sub>IL</sub>	V <sub>IL</sub>	V <sub>IH</sub>	V <sub>IL</sub>	V <sub>IL</sub>	V <sub>IL</sub>	V <sub>ID</sub>	V <sub>IH</sub>	V <sub>IH</sub>	Manufacturer-Equivalent Code 01h (TMS29LF008)
3-V power supply	V <sub>IL</sub>	V <sub>IL</sub>	V <sub>IH</sub>	V <sub>IH</sub>	V <sub>IL</sub>	V <sub>IL</sub>	V <sub>ID</sub>	V <sub>IH</sub>	V <sub>IH</sub>	Device-Equivalent Code 3Eh (TMS29LF008T)
	V <sub>IL</sub>	V <sub>IL</sub>	V <sub>IH</sub>	V <sub>IH</sub>	V <sub>IL</sub>	V <sub>IL</sub>	V <sub>ID</sub>	V <sub>IH</sub>	V <sub>IH</sub>	Device-Equivalent Code 37h (TMS29LF008B)
Read	V <sub>IL</sub>	V <sub>IL</sub>	V <sub>IH</sub>	A0	A1	A6	A9	V <sub>IH</sub>	V <sub>IH</sub>	Data out
Output disable	V <sub>IL</sub>	V <sub>IH</sub>	V <sub>IH</sub>	X	X	X	X	V <sub>IH</sub>	V <sub>IH</sub>	Hi-Z
Standby and write inhibit	V <sub>IH</sub>	X	X	X	X	X	X	V <sub>IH</sub>	V <sub>IH</sub>	Hi-Z
Write§	V <sub>IL</sub>	V <sub>IH</sub>	V <sub>IL</sub>	A0	A1	A6	A9	V <sub>IH</sub>	V <sub>IH</sub>	Data in
Temporary sector unprotect	X	X	X	X	X	X	X	V <sub>ID</sub>	V <sub>ID</sub>	X
Verify sector protect	V <sub>IL</sub>	V <sub>IL</sub>	V <sub>IH</sub>	V <sub>IL</sub>	V <sub>IH</sub>	V <sub>IL</sub>	V <sub>ID</sub>	V <sub>IH</sub>	V <sub>IH</sub>	Data out
Hardware reset	X	X	X	X	X	X	X	V <sub>IL</sub>	V <sub>IL</sub>	Hi-Z

Legend:

V<sub>IL</sub> = Logic low

V<sub>IH</sub> = Logic high

V<sub>ID</sub> = 12.0 ± 0.5 V

‡ X can be V<sub>IL</sub> or V<sub>IH</sub>.

§ See Table 5 for valid address and data during write.

# TMS29LF008T, TMS29LF008B

## 1048576 BY 8-BIT

### FLASH MEMORIES

SMJS846A – MAY 1997 – REVISED NOVEMBER 1997

#### read mode

A logic-low signal applied to the  $\overline{CE}$  and  $\overline{OE}$  pins allows the output of the TMS29LF008T/B to be read. When two or more '29LF008T/B devices are connected in parallel, the output of any one device can be read without interference. The  $\overline{CE}$  pin is for power control and must be used for device selection. The  $\overline{OE}$  pin is for output control, and is used to gate the data output onto the bus from the selected device.

The address-access time ( $t_{AVQV}$ ) is the delay from stable address to valid output data. The chip-enable ( $\overline{CE}$ ) access time ( $t_{ELQV}$ ) is the delay from  $\overline{CE}$  low and stable addresses to valid output data. The output-enable access time ( $t_{GLQV}$ ) is the delay from  $\overline{OE}$  low to valid output data when  $\overline{CE}$  equals logic low, and addresses are stable for at least the duration of  $t_{AVQV} - t_{GLQV}$ .

#### standby mode

$I_{CC}$  supply current is reduced by applying a logic-high level on  $\overline{CE}$  and  $\overline{RESET}$  to enter the standby mode. In the standby mode, the outputs are placed in the high-impedance state. Applying a CMOS logic-high level on  $\overline{CE}$  and  $\overline{RESET}$  reduces the current to 60  $\mu$ A. Applying a TTL logic-high level on  $\overline{CE}$  and  $\overline{RESET}$  reduces the current to 1 mA. If the '29LF008T/B is deselected during erasure or programming, the device continues to draw active current until the operation is complete.

#### output disable

When  $\overline{OE}$  equals  $V_{IH}$  or  $\overline{CE}$  equals  $V_{IH}$ , output from the device is disabled and the output pins (DQ0–DQ7) are placed in the high-impedance state.

#### automatic-sleep mode

The '29LF008T/B has a built-in feature called automatic-sleep mode to minimize device energy consumption which is independent of  $\overline{CE}$ ,  $\overline{WE}$ , and  $\overline{OE}$ , and is enabled when addresses remain stable for 300 ns. Typical sleep-mode current is 60  $\mu$ A. Sleep mode does not affect output data, which remains latched and available to the system.

#### algorithm selection

The algorithm-selection mode provides access to a binary code that matches the device with its proper programming and erase command operations. This mode is activated when  $V_{ID}$  (11.5 V to 12.5 V) is placed on address pin A9. Address pins A1 and A6 must be logic low. Two bytes of code are accessed by toggling address pin A0 from  $V_{IL}$  to  $V_{IH}$ . Address pins other than A0, A1, and A6 can be at logic low or at logic high.

The algorithm-selection mode can also be read by using the command register, which is useful when  $V_{ID}$  is not available to be placed on address pin A9. Table 4 shows the binary algorithm-selection codes.

**Table 4. Algorithm-Selection Codes (3-V Single Power Supply)<sup>†</sup>**

	CODE	DQ7	DQ6	DQ5	DQ4	DQ3	DQ2	DQ1	DQ0
Manufacturer-equivalent code	01H	0	0	0	0	0	0	0	1
TMS29LF008T	3EH	0	0	1	1	1	1	1	0
TMS29LF008B	37H	0	0	1	1	0	1	1	1
Sector protection	01H	0	0	0	0	0	0	0	1

<sup>†</sup> A1 =  $V_{IL}$ , A6 =  $V_{IL}$ ,  $\overline{CE}$  =  $V_{IL}$ ,  $\overline{OE}$  =  $V_{IL}$



## erasure and programming

Erase and programming of the '29LF008 are accomplished by writing a sequence of commands using standard microprocessor write timing. The commands are written to a command register and input to the command-state machine (CSM). The CSM interprets the command entered and initiates program, erase, suspend, and resume operations as instructed. The CSM acts as the interface between the write-state machine (WSM) and external-chip operations. The WSM controls all voltage generation, pulse generation, preconditioning, and verification of memory contents. Program and block-/chip-erase functions are fully automatic. Once the end of a program or erase operation has been reached, the device resets internally to the read mode. If  $V_{CC}$  drops below the low-voltage-detect level ( $V_{LKO}$ ), any programming or erase operation is aborted and subsequent writes are ignored until the  $V_{CC}$  level is greater than  $V_{LKO}$ . The control pins must be logically correct to prevent unintentional command writes or programming or erasing.

## command definitions

Device operating modes are selected by writing specific address and data sequences into the command register. Table 5 defines the valid command sequences. Writing incorrect address and data values or writing them in the incorrect sequence causes the device to reset to the read mode. The command register does not occupy an addressable memory location. The register is used to store the command sequence, along with the address and data needed by the memory array. Commands are written by setting  $\overline{CE} = V_{IL}$ ,  $\overline{OE} = V_{IH}$ , and bringing  $\overline{WE}$  from logic high to logic low. Addresses are latched on the falling edge of  $\overline{WE}$  and data is latched on the rising edge of  $\overline{WE}$ . Holding  $\overline{WE} = V_{IL}$  and toggling  $\overline{CE}$  is an alternative method. See the switching characteristics of the write/erase/program-operations section for specific timing information.

Table 5. Command Definitions

COMMAND	BUS CYCLES	1ST CYCLE		2ND CYCLE		3RD CYCLE		4TH CYCLE		5TH CYCLE		6TH CYCLE	
		ADDR	DATA	ADDR	DATA	ADDR	DATA	ADDR	DATA	ADDR	DATA	ADDR	DATA
Read/reset	1	XXXXH	F0H										
	3	555H	AAH	2AAH	55H	555H	F0H	RA	RD				
Algorithm selection	3	555H	AAH	2AAH	55H	555H	90H	01H	3EH	T			
									37H	B			
Program	4	555H	AAH	2AAH	55H	555H	A0H	PA	PD				
Chip erase	6	555H	AAH	2AAH	55H	555H	80H	555H	AAH	2AAH	55H	555H	10H
Sector erase	6	555H	AAH	2AAH	55H	555H	80H	555H	AAH	2AAH	55H	SA	30H
Sector-erase suspend	1	XXXXH	B0H	Erase suspend valid during sector-erase operation									
Sector-erase resume	1	XXXXH	30H	Erase resume valid only after erase suspend									

### LEGEND:

- RA = Address of the location to be read
- PA = Address of the location to be programmed
- SA = Address of the sector to be erased  
Addresses A13–A19 select 1 to 19 sectors.
- RD = Data to be read at selected address location
- PD = Data to be programmed at selected address location

### read/reset command

The read or reset mode is activated by writing either of the two read/reset command sequences into the command register. The device remains in this mode until another valid command sequence is input in the command register. Memory data is available in the read mode and can be read with standard microprocessor read-cycle timing.

On power up, the device defaults to the read/reset mode. A read/reset command sequence is not required and memory data is available.

### algorithm-selection command

The algorithm-selection command allows access to a binary code that matches the device with the proper programming and erase command operations. After writing the three-bus-cycle command sequence, the first byte of the algorithm-selection code can be read from address XX00h. The second byte of the code can be read from address XX01h (see Table 5). This mode remains in effect until another valid command sequence is written to the device.

### byte-program command

Programming is a four-bus-cycle command sequence. The first three bus cycles put the device into the program-setup state. The fourth bus cycle loads the address location and the data to be programmed into the device. The addresses are latched on the falling edge of  $\overline{WE}$  and the data is latched on the rising edge of  $\overline{WE}$  in the fourth bus cycle. The rising edge of  $\overline{WE}$  starts the program operation. The embedded programming function automatically provides needed voltage and timing to program and verify the cell margin. Any further commands written to the device during the program operation are ignored.

Programming can be performed at any address location in any sequence. When erased, all bits are in a logic-high state. Logic lows are programmed into the device and only an erase operation can change bits from logic lows to logic highs. Attempting to program a 1 into a bit that has been programmed previously to a 0 causes the internal-pulse counter to exceed the pulse-count limit, which sets the exceed-time-limit indicator (DQ5) to a logic-high state. The automatic-programming operation is complete when the data on DQ7 is equivalent to the data written to this bit, at which time the device returns to the read mode and addresses are no longer latched. Figure 7 shows a flowchart of the typical device-programming operation.

### chip-erase command

Chip erase is a six-bus-cycle command sequence. The first three bus cycles put the device into the erase-setup state. The next two bus cycles unlock the erase mode. The sixth bus cycle loads the chip-erase command. This command sequence is required to ensure that the memory contents are not erased accidentally. The rising edge of  $\overline{WE}$  starts the chip-erase operation. Any further commands written to the device during the chip-erase operation are ignored.

The embedded chip-erase function automatically provides voltage and timing needed to program and to verify all the memory cells prior to electrical erase. It then erases and verifies the cell margin automatically without programming the memory cells prior to erase.

Figure 10 shows a flowchart of the typical chip-erase operation.

### sector-erase command

Sector-erase is a six-bus-cycle command sequence. The first three bus cycles put the device into the erase-setup state. The next two bus cycles unlock the erase mode and the sixth bus cycle loads the sector-erase command and the sector-address location to be erased. Any address location within the desired sector can be used. The addresses are latched on the falling edge of  $\overline{WE}$  and the sector-erase command (30h) is latched on the rising edge of  $\overline{WE}$  in the sixth bus cycle. After a delay of 80  $\mu\text{s}$  from the rising edge of  $\overline{WE}$ , the sector-erase operation begins on the selected sector(s).

Additional sectors can be selected to be erased concurrently during the sector-erase command sequence. For each additional sector to be selected for erase, another bus cycle is issued. The bus cycle loads the next sector-address location and the sector-erase command. The time between the end of the previous bus cycle and the start of the next bus cycle must be less than 100  $\mu\text{s}$ ; otherwise, the new sector location is not loaded. A time delay of 100  $\mu\text{s}$  from the rising edge of the last  $\overline{WE}$  starts the sector-erase operation. If there is a falling edge of  $\overline{WE}$  within the 100  $\mu\text{s}$  time delay, the timer is reset.

One to nineteen sector-address locations can be loaded in any sequence. The state of the delay timer can be monitored using the sector-erase delay indicator (DQ3). If DQ3 is at logic low, the time delay has not expired. See the operation status section for a description.

Any command other than erase suspend (B0h) or sector erase (30h) written to the device during the sector-erase operation causes the device to exit the sector-erase mode and the contents of the sector(s) selected for erase are no longer valid. To complete the sector-erase operation, re-issue the sector-erase command sequence.

The embedded sector-erase function automatically provides needed voltage and timing to program and to verify all of the memory cells prior to electrical erase and then erases and verifies the cell margin automatically. Programming the memory cells prior to erase is not required.

See the operation status section for a full description. Figure 12 shows a flowchart of the typical sector-erase operation.

### erase-suspend command

The erase-suspend command (B0h) allows interruption of a sector-erase operation to read data from unaltered sectors of the device. Erase-suspend is a one-bus-cycle command. The addresses can be  $V_{IL}$  or  $V_{IH}$  and the erase-suspend command (B0h) is latched on the rising edge of  $\overline{WE}$ . Once the sector-erase operation is in progress, the erase-suspend command requests the internal write-state machine to halt operation at predetermined breakpoints. The erase-suspend command is valid only during the sector-erase operation and is invalid during programming and chip-erase operations. The sector-erase delay timer expires immediately if the erase-suspend command is issued while the delay is active.

After the erase-suspend command is issued, the device takes between 0.1  $\mu\text{s}$  and 15  $\mu\text{s}$  to suspend the operation. The toggle bit must be monitored to determine when the suspend has been executed. When the toggle bit stops toggling, data can be read from sectors that are not selected for erase. Reading from a sector selected for erase can result in invalid data. See the operation status section for a full description.

Once the sector-erase operation is suspended, reading from or programming to a sector that is not being erased can be performed. This command is applicable only during sector-erase operation. Any other command written during erase-suspend mode to the suspended sector is ignored.

# TMS29LF008T, TMS29LF008B

## 1048576 BY 8-BIT

### FLASH MEMORIES

SMJS846A – MAY 1997 – REVISED NOVEMBER 1997

#### erase-resume command

The erase-resume command (30h) restarts a suspended sector-erase operation from the point where it was halted. Erase resume is a one-bus-cycle command. The addresses can be  $V_{IL}$  or  $V_{IH}$  and the erase-resume command (30h) is latched on the rising edge of  $\overline{WE}$ . When an erase-suspend/erase-resume command combination is written, the internal-pulse counter (exceed timing limit) is reset. The erase-resume command is valid only in the erase-suspend state. After the erase-resume command is executed, the device returns to the valid sector-erase state and further writes of the erase-resume command are ignored. After the device has resumed the sector-erase operation, another erase-suspend command can be issued to the device.

#### operation status

The status of the device during an automatic-programming algorithm, chip-erase, or automatic-erase algorithm can be determined in three ways:

- DQ7: Data polling
- DQ6: Toggle bit
- RY/ $\overline{BY}$ : Ready/busy bit

#### status-bit definitions

During operation of the automatic embedded program and erase functions, the status of the device can be determined by reading the data state of designated outputs. The data-polling bit (DQ7) and toggle bit (DQ6) require multiple successive reads to observe a change in the state of the designated output. Table 6 defines the values of the status flags.

Table 6. Operation Status Flags†

DEVICE OPERATION‡		DQ7	DQ6	DQ5	DQ3	DQ2	RY/ $\overline{BY}$	
In progress	Programming	$\overline{DQ7}$	T	0	0	No Tog	0	
	Program/erase in auto-erase	0	T	0	1	§	0	
	Erase-suspend mode	Erase-sector address	1	No Tog	0	0	T	1
		Non-erase sector address	D	D	D	D	D	1
	Program in erase suspend	$\overline{DQ7}$ ¶	T	0	0	‡§	0	
Exceeded time limits	Programming	$\overline{DQ7}$	T	1	0	No Tog	0	
	Program/erase in auto erase	0	T	1	1	#	0	
	Program in erase suspend	$\overline{DQ7}$	T	1	0	No Tog	0	
Successful operation complete	Programming complete	D	D	D	D	D	1	
	Sector /chip erase complete	1	1	1	1	1	1	

† T= toggle, D= data, No Tog= no toggle

‡ DQ4, DQ1, DQ0 are reserved for future use.

§ DQ2 can be toggled when the sector address applied is an erasing sector. DQ2 cannot be toggled when the sector address applied is a non-erasing sector. DQ2 is used to determine which sectors are erasing and which are not.

¶ Status flags apply when outputs are read from the address of a non-erase-suspend operation.

# If DQ5 is high (exceeded timing limits), successive reads from a problem sector causes DQ2 to toggle.

PRODUCT PREVIEW



### data-polling (DQ7)

The data-polling-status function outputs the complement of the data latched into the DQ7 data register while the write-state machine is engaged in a program or erase operation. The changing of data bit DQ7 from complement to true indicates the end of an operation. Data-polling is available only during programming, chip-erase, sector-erase, and sector-erase-timing delay. Data-polling is valid after the rising edge of  $\overline{WE}$  in the last bus cycle of the command sequence loaded into the command register. Figure 14 shows a flowchart for data-polling.

During a program operation, reading DQ7 outputs the complement of the DQ7 data to be programmed at the selected address location. Upon completion, reading DQ7 outputs the true DQ7 data loaded into the program-data register. During the erase operations, reading DQ7 outputs a logic low. Upon completion, reading DQ7 outputs a logic high. Also, data-polling must be performed at a sector address that is within a sector that is being erased. Otherwise, the status is invalid. When using data-polling, the address should remain stable throughout the operation.

During a data-polling read, while  $\overline{OE}$  is logic low, data bit DQ7 can change asynchronously. Depending on the read timing, the system can read valid data on DQ7, while other DQ pins are still invalid. A subsequent read of the device is valid. See Figure 15 for the data-polling timing diagram.

### toggle bit (DQ6)

The toggle-bit status function outputs data on DQ6, which toggles between logic high and logic low while the write-state machine is engaged in a program or erase operation. When DQ6 stops toggling after two consecutive reads to the same address, the operation is complete. The toggle bit is available only during programming, chip erase, sector erase, and sector-erase-timing delay. Toggle-bit data is valid after the rising edge of  $\overline{WE}$  in the last bus cycle of the command sequence loaded into the command register. Figure 16 shows a flowchart of the toggle-bit status-read algorithm. Depending on the read timing, DQ6 can stop toggling while other DQ pins are still invalid and a subsequent read of the device is valid. See Figure 17 for the toggle-bit timing diagram.

### exceed time limit (DQ5)

The program and erase operations use an internal-pulse counter to limit the number of pulses applied. If the pulse-count limit is exceeded, DQ5 is set to a logic-high data state. This indicates that the program or erase operation has failed. DQ7 does not change from complemented data to true data and DQ6 does not stop toggling when read. To continue operation, the device must be reset.

The exceed-time-limit condition occurs when attempting to program a logic-high state into a bit that has been programmed previously to a logic low. Only an erase operation can change bits from logic low to logic high. After reset, the device is functional and can be erased and reprogrammed.

### sector-load-timer (DQ3)

The sector-load-timer status bit, DQ3, is used to determine whether the time to load additional sector addresses has expired. After completion of a sector-erase command sequence, DQ3 remains at a logic low for 100  $\mu$ s. This indicates that another sector-erase command sequence can be issued. If DQ3 is at a logic high, it indicates that the delay has expired and attempts to issue additional sector-erase commands are ignored. See the sector-erase command section for a description.

The data-polling and toggle bit are valid during the 100- $\mu$ s time delay and can be used to determine if a valid sector-erase command has been issued. To ensure additional sector-erase commands have been accepted, the status of DQ3 should be read before and after each additional sector-erase command. If DQ3 is at a logic low on both reads, the additional sector-erase command was accepted.

**toggle bit 2 (DQ2)**

The state of DQ2 determines whether the device is in algorithmic-erase mode or erase-suspend mode. DQ2 toggles if successive reads are issued to the erasing or erase-suspended sector, assuming in case of the latter that the device is in erase-suspend-read mode. It also toggles when DQ5 becomes a logic high due to timer-exceed limit and reads are issued to the failed sector. DQ2 does not toggle in any other sector due to DQ5 failure. When the device is in erase-suspend-program mode, successive reads from the non-erase-suspended sector causes a logic high on DQ2.

**ready/busy bit (RY/ $\overline{\text{BY}}$ )**

The RY/ $\overline{\text{BY}}$  bit indicates when the device can accept new commands after performing algorithmic operations. If the RY/ $\overline{\text{BY}}$  (open-drain output) bit is low, the device is busy with either a program or erase operation and does not accept any other commands except for erase suspend. While it is in the erase-suspend mode, RY/ $\overline{\text{BY}}$  remains high. In program mode, the RY/ $\overline{\text{BY}}$  bit is valid (logic low) after the fourth  $\overline{\text{WE}}$  pulse. In erase mode, it is valid after the sixth  $\overline{\text{WE}}$  pulse. There is a delay period  $t_{\text{busy}}$ , after which the RY/ $\overline{\text{BY}}$  bit becomes valid. See Figure 24 for the timing waveform.

Since the RY/ $\overline{\text{BY}}$  bit is an open-drain output, several such bits can be combined in parallel with a pullup resistor to  $V_{\text{CC}}$ .

**hardware-reset bit ( $\overline{\text{RESET}}$ )**

When the  $\overline{\text{RESET}}$  pin is driven to a logic low, it forces the device out of the currently active mode and into a reset state. It also avoids bus contention by placing the outputs into the high-impedance state for the duration of the  $\overline{\text{RESET}}$  pulse.

During program or erase operation, if  $\overline{\text{RESET}}$  is asserted to logic low, the RY/ $\overline{\text{BY}}$  bit remains at logic low until the reset operation is complete. Since this can take anywhere from 1  $\mu\text{s}$  to 20  $\mu\text{s}$ , the RY/ $\overline{\text{BY}}$  bit can be used to sense reset completion or the user can allow a maximum of 20  $\mu\text{s}$ . If  $\overline{\text{RESET}}$  is asserted during read mode, then the reset operation is complete within 500 ns. See Figure 1 and Figure 2 for timing specifications.

The  $\overline{\text{RESET}}$  pin also can be used to drive the device into deep power-down (standby) mode by applying  $V_{\text{SS}} \pm 0.3 \text{ V}$  to it.  $I_{\text{CC4}}$  reads  $<1 \mu\text{A}$  typical, and 5  $\mu\text{A}$  maximum for CMOS inputs. Standby mode can be entered anytime, regardless of the condition of  $\overline{\text{CE}}$ .

Asserting  $\overline{\text{RESET}}$  during program or erase can leave erroneous data in the address locations. These locations need to be updated after the device resumes normal operations. A minimum of 50 ns must be allowed after  $\overline{\text{RESET}}$  goes high before a valid read can take place.

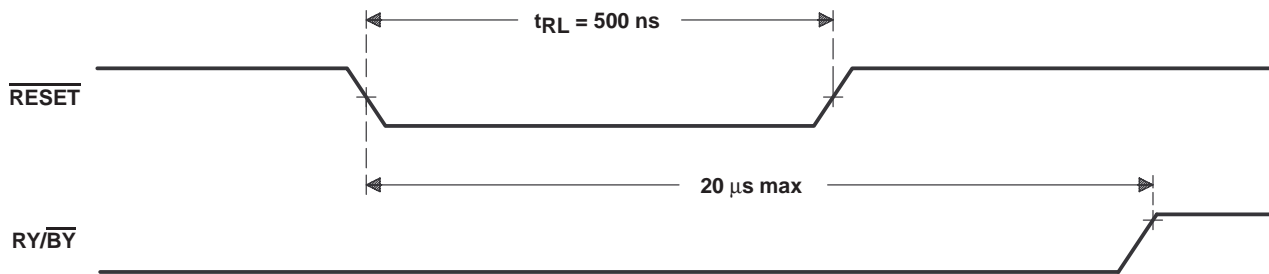

**Figure 1. Device Reset During a Program or Erase Operation**

hardware-reset bit ( $\overline{\text{RESET}}$ ) (continued)

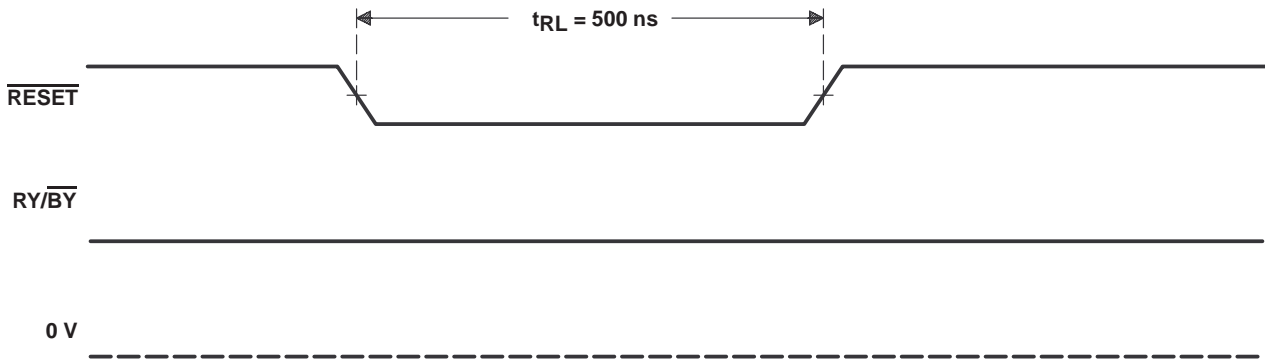

Figure 2. Device Reset During Read Mode

temporary hardware-sector unprotect feature

This feature temporarily enables both programming and erase operations on any combination of one to nineteen sectors that were previously protected. This feature is enabled using high voltage  $V_{ID}$  (11.5 V to 12.5 V) on the  $\overline{\text{RESET}}$  pin and using standard command sequences.

Normally, the device is delivered with all sectors unprotected.

sector-protect programming

The sector-protect programming mode is activated when  $A_6$ ,  $A_0$ , and  $\overline{\text{CE}}$  are at  $V_{IL}$ , and address pin  $A_9$  and control pin  $\overline{\text{OE}}$  are forced to  $V_{ID}$ . Address pin  $A_1$  is set to  $V_{IH}$ . The sector-select address pins  $A_{13}$ – $A_{19}$  are used to select the sector to be protected. Address pins  $A_0$ – $A_{12}$  and I/O pins must be stable and can be either  $V_{IL}$  or  $V_{IH}$ . Once the addresses are stable,  $\overline{\text{WE}}$  is pulsed low for 100  $\mu\text{s}$ , causing programming to begin on the falling edge of  $\overline{\text{WE}}$  and to terminate on the rising edge of  $\overline{\text{WE}}$ . Figure 18 is a flowchart of the sector-protect algorithm and Figure 19 shows a timing diagram of the sector-protect operation.

Commands to program or erase a protected sector do not change the data contained in the sector. Attempts to program and erase a protected sector cause the data-polling bit (DQ7) and the toggle bit (DQ6) to operate from 2  $\mu\text{s}$  to 100  $\mu\text{s}$  and then return to valid data.

sector-protect verify

Verification of the sector-protection programming is activated when  $\overline{\text{WE}} = V_{IH}$ ,  $\overline{\text{OE}} = V_{IL}$ ,  $\overline{\text{CE}} = V_{IL}$ , and address pin  $A_9 = V_{ID}$ . Address pins  $A_0$  and  $A_6$  are set to  $V_{IL}$ , and  $A_1$  is set to  $V_{IH}$ . The sector-address pins  $A_{13}$ – $A_{19}$  select the sector that is to be verified. The other addresses can be  $V_{IH}$  or  $V_{IL}$ . If the sector that was selected is protected, the DQs output 01h. If the sector is not protected, the DQs output 00h.

Sector-protect verify can also be read using the algorithm-selection command. After issuing the three-bus-cycle command sequence, the sector-protection status can be read on DQ0. Set address pins  $A_0 = V_{IL}$ ,  $A_1 = V_{IH}$ , and  $A_6 = V_{IL}$ , and then the sector address pins  $A_{13}$ – $A_{19}$  select the sector to be verified. The remaining addresses are set to  $V_{IL}$ . If the sector selected is protected, DQ0 outputs a logic-high state. If the sector selected is not protected, DQ0 outputs a logic-low state. This mode remains in effect until another valid command sequence is written to the device. Figure 18 is a flowchart of the sector-protect algorithm and Figure 19 shows a timing diagram of the sector-protect operation.

# TMS29LF008T, TMS29LF008B

## 1048576 BY 8-BIT

### FLASH MEMORIES

SMJS846A – MAY 1997 – REVISED NOVEMBER 1997

---

#### sector unprotect

Prior to sector unprotect, all sectors must be protected using the sector-protect programming mode. The sector unprotect is activated when address pin A9 and control pin  $\overline{OE}$  are forced to  $V_{ID}$ . Address pins A1 and A6 are set to  $V_{IH}$  while  $\overline{CE}$  and A0 are set to  $V_{IL}$ . The sector-select address pins A13–A19 can be  $V_{IL}$  or  $V_{IH}$ . All sectors are unprotected in parallel and once the inputs are stable,  $\overline{WE}$  is pulsed low for 10 ms, causing the unprotect operation to begin on the falling edge of  $\overline{WE}$  and to terminate on the rising edge of  $\overline{WE}$ . Figure 20 is a flowchart of the sector-unprotect algorithm and Figure 21 shows a timing diagram of the sector-unprotect operation.

#### sector-unprotect verify

Verification of the sector unprotect is accomplished when  $\overline{WE} = V_{IH}$ ,  $\overline{OE} = V_{IL}$ ,  $\overline{CE} = V_{IL}$ , and A9 =  $V_{ID}$ , and then select the sector to be verified. Address pins A1 and A6 are set to  $V_{IH}$ , and A0 is set to  $V_{IL}$ . The other addresses can be  $V_{IH}$  or  $V_{IL}$ . If the sector selected is protected, the DQs output 01h. If the sector is not protected, the DQs output 00h. Sector unprotect can also be read using the algorithm-selection command.

#### low $V_{CC}$ write lockout

During power-up and power-down operations, write cycles are locked out for  $V_{CC}$  less than  $V_{LKO}$ . If  $V_{CC} < V_{LKO}$ , the command input is disabled and the device is reset to the read mode. On power up, if  $\overline{CE} = V_{IL}$ ,  $\overline{WE} = V_{IL}$ , and  $\overline{OE} = V_{IH}$ , the device does not accept commands on the rising edge of  $\overline{WE}$ . The device automatically powers up in the read mode.

#### glitching

Pulses of less than 5 ns (typical) on  $\overline{OE}$ ,  $\overline{WE}$ , or  $\overline{CE}$  do not issue a write cycle.

#### power supply considerations

Each device should have a 0.1- $\mu$ F ceramic capacitor connected between  $V_{CC}$  and  $V_{SS}$  to suppress circuit noise. Printed circuit traces to  $V_{CC}$  should be appropriate to handle the current demand and minimize inductance.



**absolute maximum ratings over ambient temperature range (unless otherwise noted)†**

Supply voltage range, $V_{CC}$ (see Note 1)	–0.6 V to 7 V
Input voltage range: All inputs except A9, $\overline{CE}$ , $\overline{OE}$ (see Note 2)	–0.6 V to $V_{CC} + 1$ V
A9, $\overline{CE}$ , $\overline{OE}$	–0.6 V to 13.5 V
Output voltage range (see Note 3)	–0.6 V to $V_{CC} + 1$ V
Ambient temperature range during read/erase/program, $T_A$	
(L)	0°C to 70°C
(E)	–40°C to 85°C
(Q)	–40°C to 125°C
Storage temperature range, $T_{stg}$	–65°C to 150°C

† Stresses beyond those listed under “absolute maximum ratings” may cause permanent damage to the device. These are stress ratings only, and functional operation of the device at these or any other conditions beyond those indicated under “recommended operating conditions” is not implied. Exposure to absolute-maximum-rated conditions for extended periods may affect device reliability.

- NOTES: 1. All voltage values are with respect to  $V_{SS}$ .  
 2. The voltage on any input pin can undershoot to –2 V for periods less than 20 ns (see Figure 4).  
 3. The voltage on any input or output pin can overshoot to 7 V for periods less than 20 ns (see Figure 5).

**recommended operating conditions**

		MIN	MAX	UNIT	
$V_{CC}$	Supply voltage	2.7	3.6	V	
$V_{IH}$	High-level dc input voltage	TTL	2	$V_{CC}+0.5$	V
		CMOS	$V_{CC}-0.5$	$V_{CC}+0.5$	
$V_{IL}$	Low-level dc input voltage	TTL	–0.5	0.8	V
		CMOS	–0.5	0.8	
$V_{ID}$	Algorithm selection and sector-protect input voltage	11.5	12.5	V	
$V_{LKO}$	Low $V_{CC}$ lock-out voltage	2.3	2.5	V	
$T_A$	Ambient temperature	L version	0	70	°C
		E version	–40	85	
		Q version	–40	125	

PRODUCT PREVIEW

**TMS29LF008T, TMS29LF008B**  
**1048576 BY 8-BIT**  
**FLASH MEMORIES**

SMJS846A – MAY 1997 – REVISED NOVEMBER 1997

**electrical characteristics over recommended ranges of supply voltage and ambient temperature**

PARAMETER		TEST CONDITIONS	MIN	MAX	UNIT
V <sub>OH</sub>	High-level output voltage	TTL-input level	V <sub>CC</sub> = V <sub>CC</sub> MIN, I <sub>OH</sub> = -2.0 mA		0.85*V <sub>CC</sub>
		CMOS-input level	V <sub>CC</sub> = V <sub>CC</sub> MIN, I <sub>OH</sub> = -100 μA		V <sub>CC</sub> -0.4
V <sub>OL</sub>	Low-level output voltage	V <sub>CC</sub> = V <sub>CC</sub> MIN, I <sub>OL</sub> = 5.8 mA		0.45	V
I <sub>I</sub>	Input current (leakage)	V <sub>CC</sub> = V <sub>CC</sub> MAX, V <sub>IN</sub> = V <sub>SS</sub> to V <sub>CC</sub>		±1	μA
I <sub>O</sub>	Output current (leakage)	V <sub>O</sub> = V <sub>SS</sub> to V <sub>CC</sub> , $\overline{CE} = V_{IH}$		±1	μA
I <sub>ID</sub>	High-voltage current (standby)	A9 or $\overline{CE}$ or $\overline{OE} = V_{ID}$ MAX		35	μA
I <sub>CC1</sub>	V <sub>CC</sub> supply current (standby)	TTL-input level	$\overline{CE} = V_{IH}, V_{CC} = V_{CC}$ MAX		1
		CMOS-input level	$\overline{CE} = V_{CC} \pm 0.2, V_{CC} = V_{CC}$ MAX		60
I <sub>CC2</sub>	V <sub>CC</sub> supply current (see Note 4 and Note 5)	$\overline{CE} = V_{IL}, \overline{OE} = V_{IH}$		30	mA
I <sub>CC3</sub>	V <sub>CC</sub> supply current (see Note 6)	$\overline{CE} = V_{IL}, \overline{OE} = V_{IH}$		60	mA
I <sub>CC4</sub>	V <sub>CC</sub> supply current (standby during reset)	V <sub>CC</sub> = V <sub>CC</sub> MAX, RESET = V <sub>SS</sub> ± 0.3 V		5	μA
I <sub>CC5</sub>	Automatic sleep mode (see Note 5 and Note 7)	V <sub>IH</sub> = V <sub>CC</sub> ± 0.3 V, V <sub>IL</sub> = V <sub>SS</sub> ± 0.3 V		60	μA

- NOTES: 4. I<sub>CC</sub> current in the read mode, switching at 6 MHz  
5. I<sub>OUT</sub> = 0 mA  
6. I<sub>CC</sub> current while erase or program operation is in progress  
7. Automatic sleep mode is entered when addresses remain stable for 300 ns.

**capacitance over recommended ranges of supply voltage and ambient temperature**

PARAMETER		TEST CONDITIONS	MIN	MAX	UNIT
C <sub>i1</sub>	Input capacitance (All inputs except A9, $\overline{CE}$ , $\overline{OE}$ )	V <sub>I</sub> = 0 V, f = 1 MHz		7.5	pF
C <sub>i2</sub>	Input capacitance (A9, $\overline{CE}$ , $\overline{OE}$ )	V <sub>I</sub> = 0 V, f = 1 MHz		9	pF
C <sub>o</sub>	Output capacitance	V <sub>O</sub> = 0 V, f = 1 MHz		12	pF

PRODUCT PREVIEW



PARAMETER MEASUREMENT INFORMATION

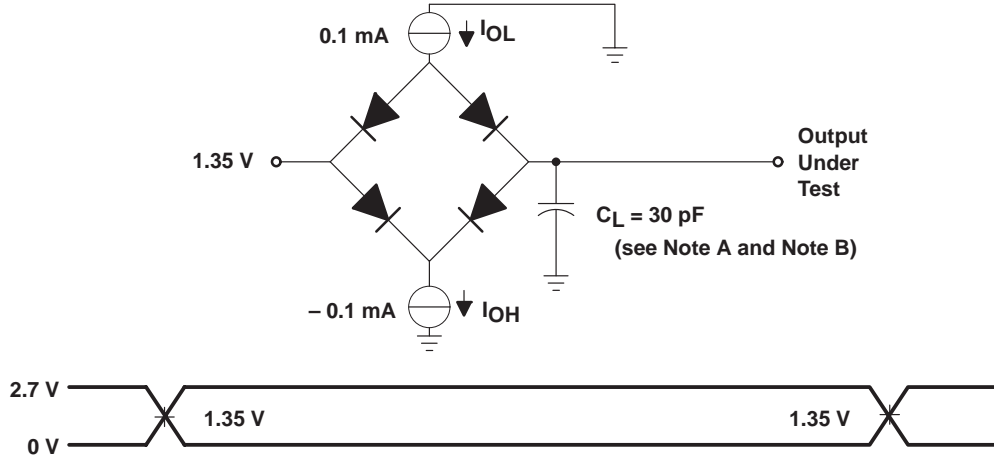

- NOTES: A.  $C_L$  includes probe and fixture capacitance.  
 B. The ac testing inputs are driven at 2.7 V for logic high and 0 V for logic low. Timing measurements are made at 1.35 V for logic high and 1.35 V for logic low on both inputs and outputs. Each device should have a 0.1- $\mu$ F ceramic capacitor connected between  $V_{CC}$  and  $V_{SS}$  as closely as possible to the device pins.

Figure 3. AC Test Output Load Circuit

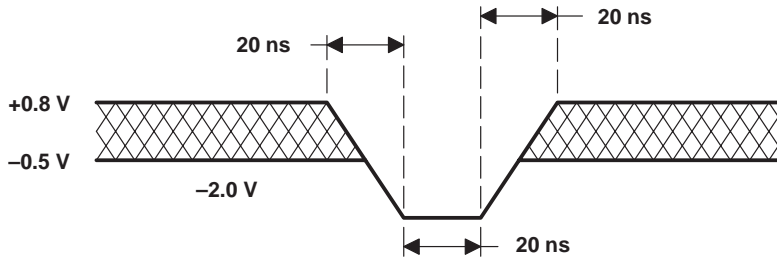

Figure 4. Maximum Negative Overshoot Waveform

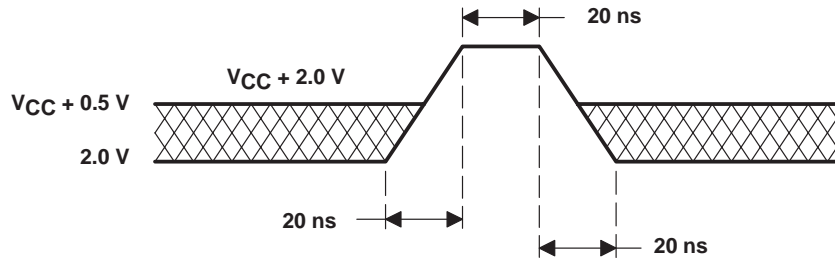

Figure 5. Maximum Positive Overshoot Waveform

TMS29LF008T, TMS29LF008B  
 1048576 BY 8-BIT  
 FLASH MEMORIES

SMJS846A – MAY 1997 – REVISED NOVEMBER 1997

PARAMETER MEASUREMENT INFORMATION

switching characteristics over recommended ranges of supply voltage and ambient temperature, read-only operation

PARAMETER	ALTERNATE SYMBOL	'29LF008-90		'29LF008-100		'29LF008-120		UNIT
		MIN	MAX	MIN	MAX	MIN	MAX	
t <sub>c</sub> (R) Cycle time, read	t <sub>AVAV</sub>	90		100		120		ns
t <sub>a</sub> (A) Access time, address	t <sub>AVQV</sub>		90		100		120	ns
t <sub>a</sub> (E) Access time, $\overline{CE}$	t <sub>ELQV</sub>		90		100		120	ns
t <sub>a</sub> (G) Access time, $\overline{OE}$	t <sub>GLQV</sub>		40		50		55	ns
t <sub>dis</sub> (E) Disable time, $\overline{CE}$ to high impedance	t <sub>EHQZ</sub>		30		30		40	ns
t <sub>dis</sub> (G) Disable time, $\overline{OE}$ to high impedance	t <sub>GHQZ</sub>		30		30		40	ns
t <sub>en</sub> (E) Enable time, $\overline{CE}$ to low impedance	t <sub>ELQX</sub>	0		0		0		ns
t <sub>en</sub> (G) Enable time, $\overline{OE}$ to low impedance	t <sub>GLQX</sub>	0		0		0		ns
t <sub>h</sub> (D) Hold time, output from address $\overline{CE}$ or $\overline{OE}$ change	t <sub>AXQX</sub>	0		0		0		ns

PRODUCT PREVIEW



switching characteristics over recommended ranges of supply voltage and ambient temperature, controlled by  $\overline{WE}$ 

PARAMETER	ALTERNATE SYMBOL	'29LF008-90			'29LF008-100			'29LF008-120			UNIT
		MIN	TYP	MAX	MIN	TYP	MAX	MIN	TYP	MAX	
$t_{c(W)}$ Cycle time, write	$t_{AVAV}$	90			100			120			ns
$t_{su(A)}$ Setup time, address	$t_{AVWL}$	0			0			0			ns
$t_{h(A)}$ Hold time, address	$t_{WLAX}$	50			50			65			ns
$t_{su(D)}$ Setup time, data	$t_{DVWH}$	50			50			65			ns
$t_{h(D)}$ Hold time, data valid after $\overline{WE}$ high	$t_{WHDX}$	0			0			0			ns
$t_{su(E)}$ Setup time, $\overline{CE}$	$t_{ELWL}$	0			0			0			ns
$t_{h(E)}$ Hold time, $\overline{CE}$	$t_{EHWH}$	0			0			0			ns
$t_w(WL)$ Pulse duration, $\overline{WE}$ low	$t_{WLWH1}$	50			50			65			ns
$t_w(WH)$ Pulse duration, $\overline{WE}$ high	$t_{WHWL}$	30			30			35			ns
$t_{rec(R)}$ Recovery time, read before write	$t_{GHWL}$	0			0			0			ns
Hold time, $\overline{OE}$ read	$t_{WHGL1}$	0			0			0			ns
Hold time, $\overline{OE}$ toggle, data	$t_{WHGL2}$	10			10			10			ns
Setup time, $V_{CC}$	$t_{VCEL}$	50			50			50			$\mu$ s
Transition time, $V_{ID}$ (see Note 8 and Note 9)	$t_{HVT}$	4			4			4			$\mu$ s
Pulse duration, $\overline{WE}$ low (see Note 8)	$t_{WLWH2}$	100			100			100			$\mu$ s
Pulse duration, $\overline{WE}$ low (see Note 9)	$t_{WLWH3}$	10			10			10			ms
Setup time, $\overline{CE}$ VID to $\overline{WE}$ (see Note 9)	$t_{EHVWL}$	4			4			4			$\mu$ s
Setup time, $\overline{CE}$ $V_{ID}$ to $\overline{WE}$ (see Note 8 and Note 9)	$t_{GHVWL}$	4			4			4			$\mu$ s
$t_{c(W)PR}$ Cycle time, programming operation	$t_{WHWH1}$		8			8			8		$\mu$ s
Write recovery time from $R\overline{Y}/\overline{B\overline{Y}}$	$t_{RB}$	0			0			0			ns
$\overline{RESET}$ low time	$t_{RL}$	500			500			500			ns
$\overline{RESET}$ high time before read	$t_{RH}$	50			50			50			ns
$\overline{RESET}$ to power-down time	$t_{RPD}$	20			20			20			$\mu$ s
Program/erase valid to $R\overline{Y}/\overline{B\overline{Y}}$ delay	$t_{BUSY}$	90			90			90			ns
$t_{c(W)ER}$ Cycle time, sector-erase operation	$t_{WHWH2}$		1			1			1		s
Cycle time, chip-erase operation	$t_{WHWH3}$		6	50		6	50		6	50	s

NOTES: 8. Sector protect  
9. Sector-unprotect timing

PRODUCT PREVIEW

TMS29LF008T, TMS29LF008B  
 1048576 BY 8-BIT  
 FLASH MEMORIES

SMJS846A – MAY 1997 – REVISED NOVEMBER 1997

switching characteristics over recommended ranges of supply voltage and ambient temperature, controlled by  $\overline{CE}$

PARAMETER	ALTERNATE SYMBOL	'29LF008-90			'29LF008-100			'29LF008-120			UNIT
		MIN	TYP	MAX	MIN	TYP	MAX	MIN	TYP	MAX	
$t_{c(W)}$ Cycle time, write	$t_{AVAV}$	90			100			120			ns
$t_{su(A)}$ Setup time, address	$t_{AVEL}$	0			0			0			ns
$t_{h(A)}$ Hold time, address	$t_{ELAX}$	50			50			65			ns
$t_{su(D)}$ Setup time, data	$t_{DVEH}$	50			50			65			ns
$t_{h(D)}$ Hold time, data	$t_{EHDX}$	0			0			0			ns
$t_{su(W)}$ Setup time, $\overline{WE}$	$t_{WLEL}$	0			0			0			ns
$t_{h(W)}$ Hold time, $\overline{WE}$	$t_{EHWH}$	0			0			0			ns
$t_{w(EL)}$ Pulse duration, $\overline{CE}$ low	$t_{ELEH1}$	50			50			65			ns
$t_{w(EH)}$ Pulse duration, $\overline{CE}$ high	$t_{EHEL}$	30			30			35			ns
$t_{rec(R)}$ Recovery time, read before write	$t_{GHEL}$	0			0			0			ns
Setup time, $\overline{OE}$	$t_{GLEL}$	0			0			0			ns
$t_{h(C)}$ Hold time, $\overline{OE}$ read	$t_{EHGL1}$	0			0			0			ns
Hold time, $\overline{OE}$ toggle, data	$t_{EHGL2}$	10			10			10			ns
Programming operation	$t_{EHEH1}$		8			8			8		$\mu$ s
Cycle time, sector-erase operation	$t_{EHEH2}$		1			1			1		s
Cycle time, chip-erase operation	$t_{EHEH3}$		6	50		6	50		6	50	s

PRODUCT PREVIEW



**erase and program performance†**

PARAMETER	TEST CONDITIONS	MIN	TYP	MAX	UNIT
Sector-erase time	Excludes 00H programming prior to erasure		1‡	15§	s
Program time	Excludes system-level overhead	9	9	3600§	µs
Chip-programming time	Excludes system-level overhead		6‡	50§	s
Erase/program cycles		100 000	1 000 000		cycles

† The internal algorithms allow for 2.5-ms byte-program time. DQ5 = 1 only after a byte takes the theoretical maximum time to program. A minimal number of bytes can require significantly more programming pulses than the typical byte. The majority of the bytes program within one or two pulses. This is demonstrated by the typical and maximum programming time listed above.

‡ 25°C, 3-V  $V_{CC}$ , 100 000 cycles, typical pattern

§ Under worst-case conditions: 90°C, 2.7-V  $V_{CC}$ , 100 000 cycles

**latchup characteristics (see Note 10)**

PARAMETER	MIN	MAX	UNIT
Input voltage with respect to $V_{SS}$ on all pins except I/O pins (including A9 and $\overline{OE}$ )	-1	13	V
Input voltage with respect to $V_{SS}$ on all I/O pins	-1	$V_{CC} + 1$	V
Current	-100	100	mA

NOTE 10: Includes all pins except  $V_{CC}$  test conditions:  $V_{CC} = 3$  V, one pin at a time

**pin capacitance, all packages (see Note 11)**

PARAMETER	TEST CONDITIONS	TYP	MAX	UNIT
$C_{IN}$ Input capacitance	$V_{IN} = 0$	6	7.5	pF
$C_{OUT}$ Output capacitance	$V_{OUT} = 0$	8.5	12	pF
$C_{IN2}$ Control pin capacitance	$V_{IN} = 0$	8	10	pF

NOTE 11: Test conditions:  $T_A = 25^\circ\text{C}$ ,  $f = 1$  MHz

**data retention**

PARAMETER	TEST CONDITIONS	MIN	MAX	UNIT
Minimum pattern data retention time	150°C	10		Years
	125°C	20		

read operation

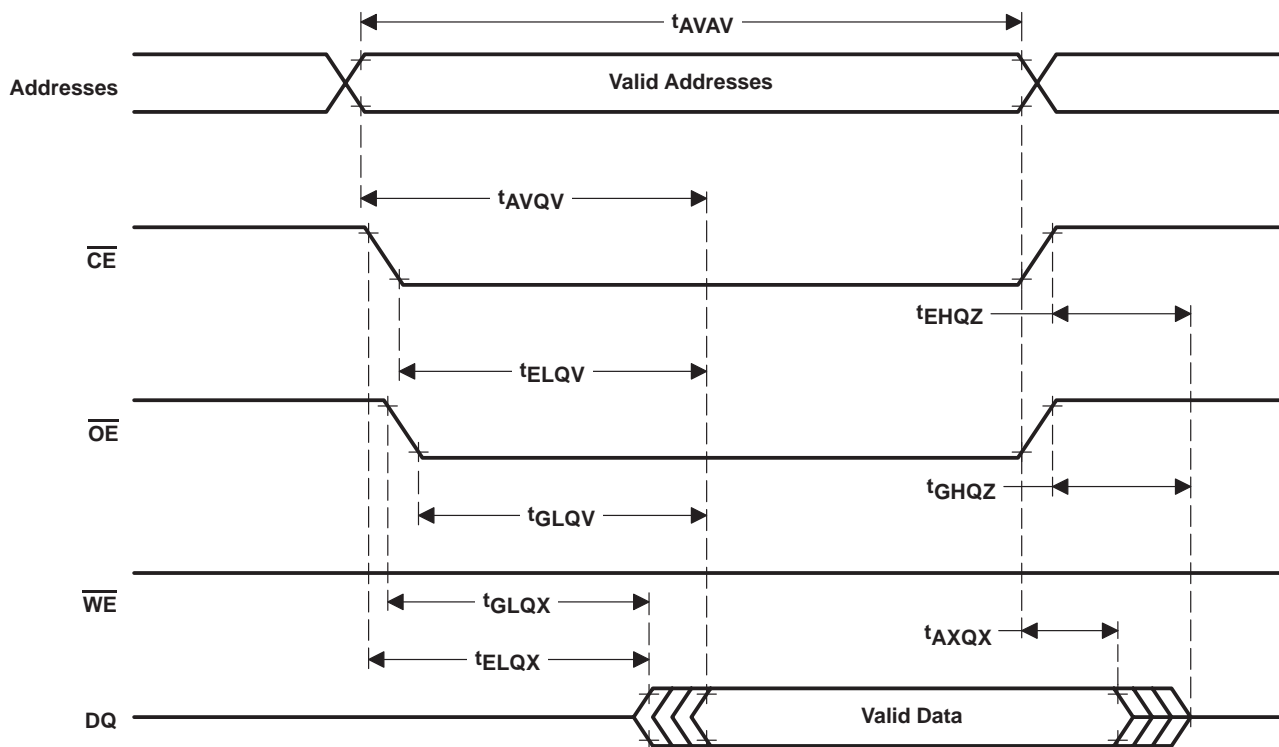

Figure 6. AC Waveform for Read Operation

PRODUCT PREVIEW



write operation

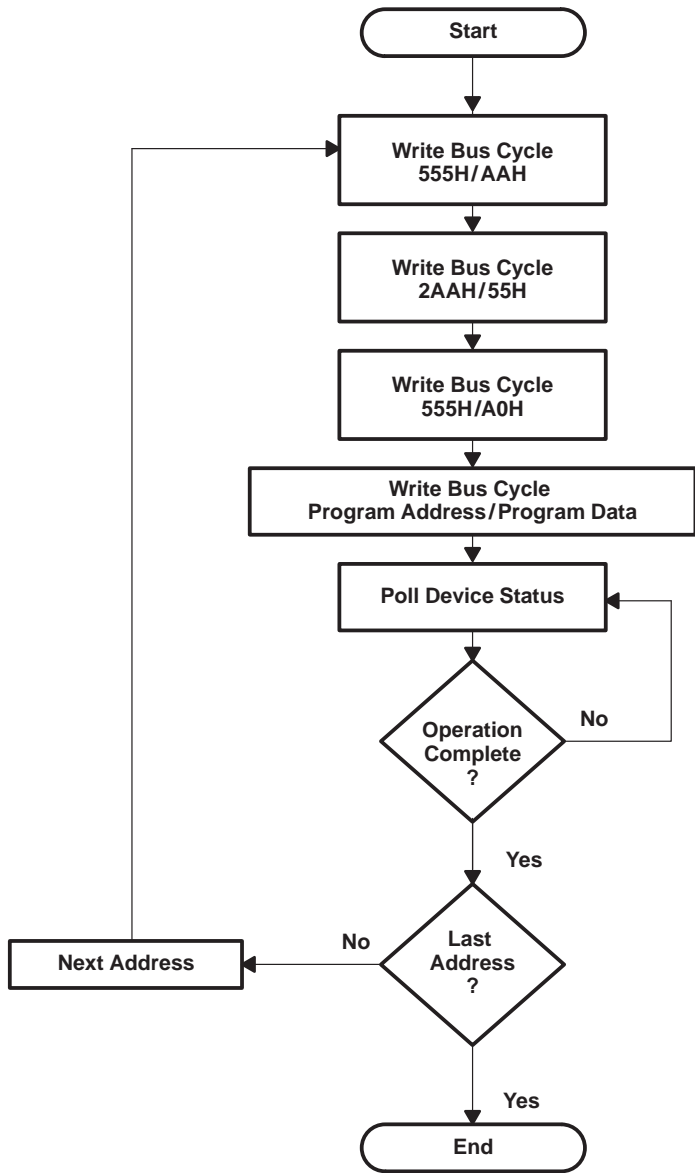

Figure 7. Program Algorithm

PRODUCT PREVIEW

TMS29LF008T, TMS29LF008B  
 1048576 BY 8-BIT  
 FLASH MEMORIES

SMJS846A – MAY 1997 – REVISED NOVEMBER 1997

write operation (continued)

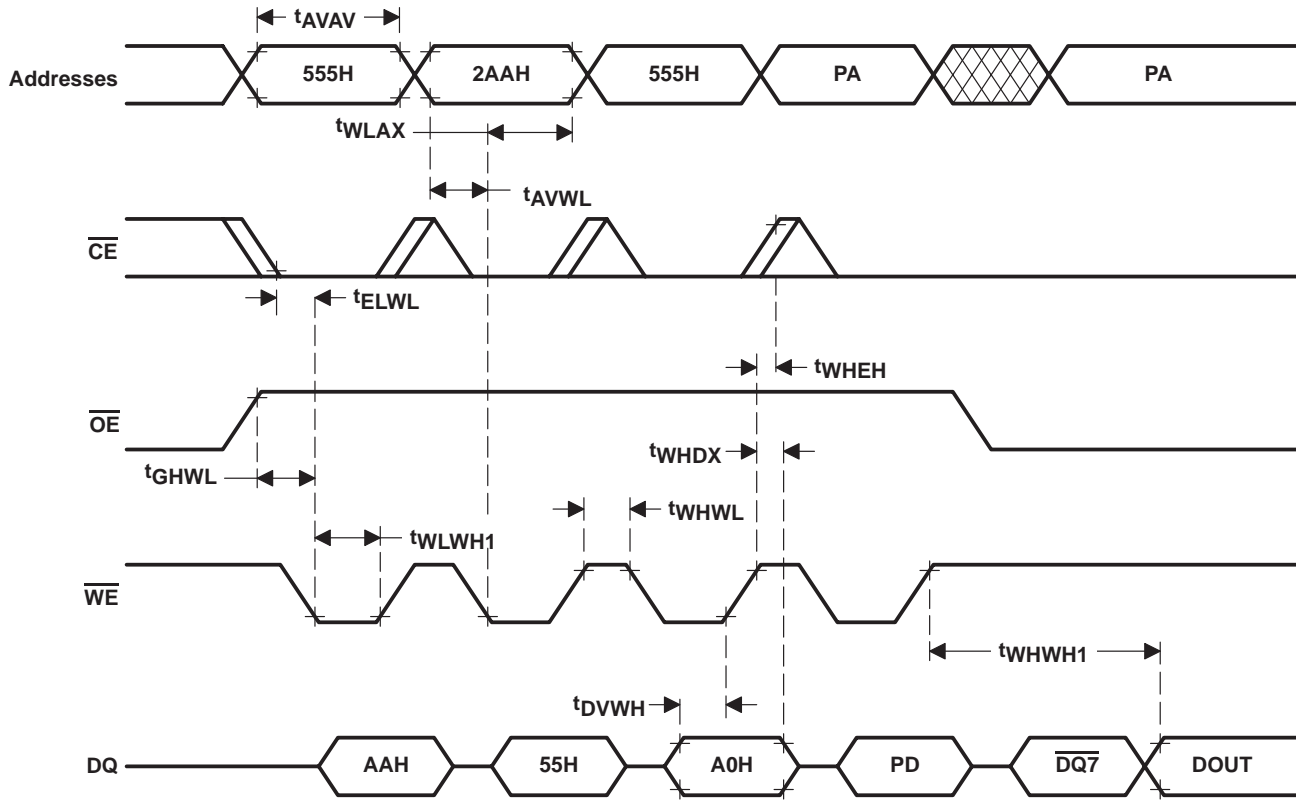

- NOTES: A. PA = Address to be programmed  
 B. PD = Data to be programmed  
 C. DQ7 = Complement of data written to DQ7

Figure 8. AC Waveform for Program Operation

PRODUCT PREVIEW



write operation (continued)

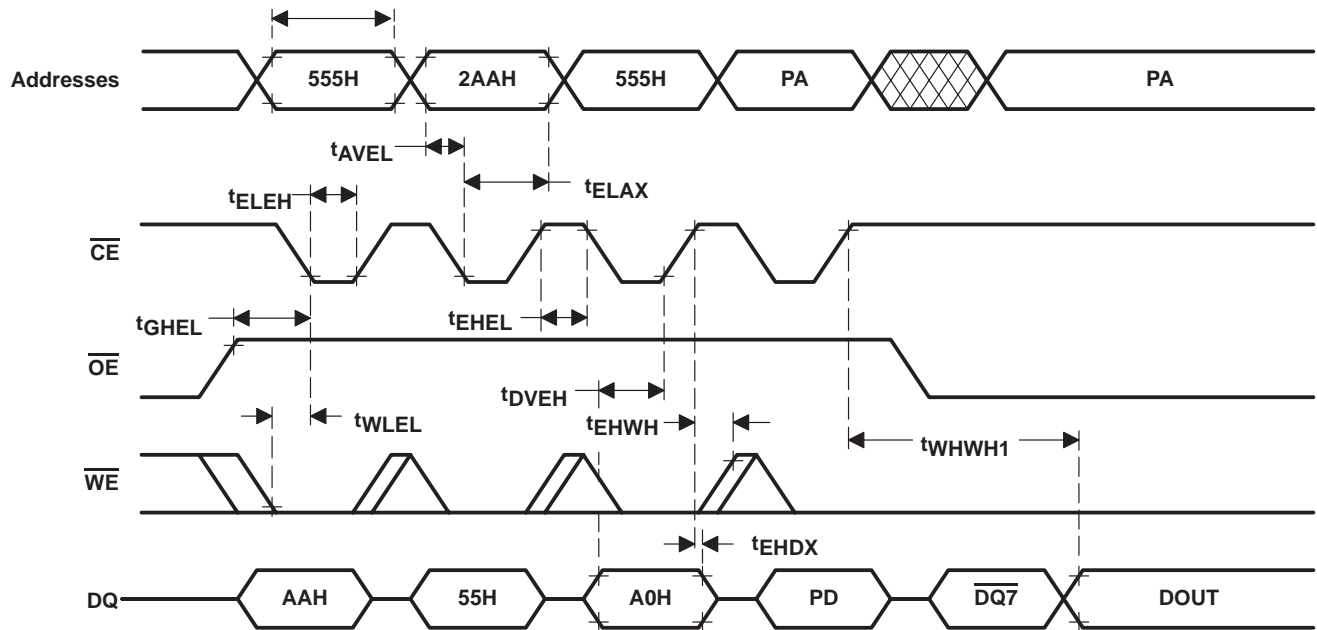

- NOTES: A. PA = Address to be programmed  
 B. PD = Data to be programmed  
 C.  $\overline{DQ7}$  = Complement of data written to DQ7

Figure 9. Alternate  $\overline{CE}$ -Controlled Write Operation

PRODUCT PREVIEW

chip-erase operation

PRODUCT PREVIEW

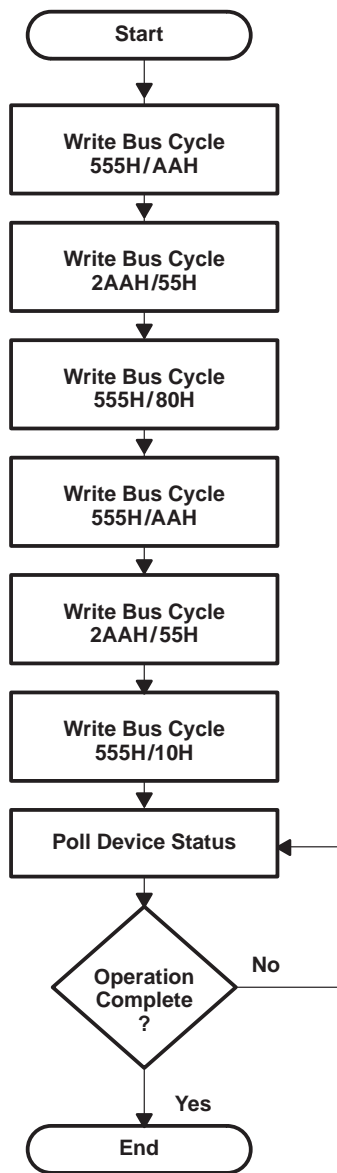
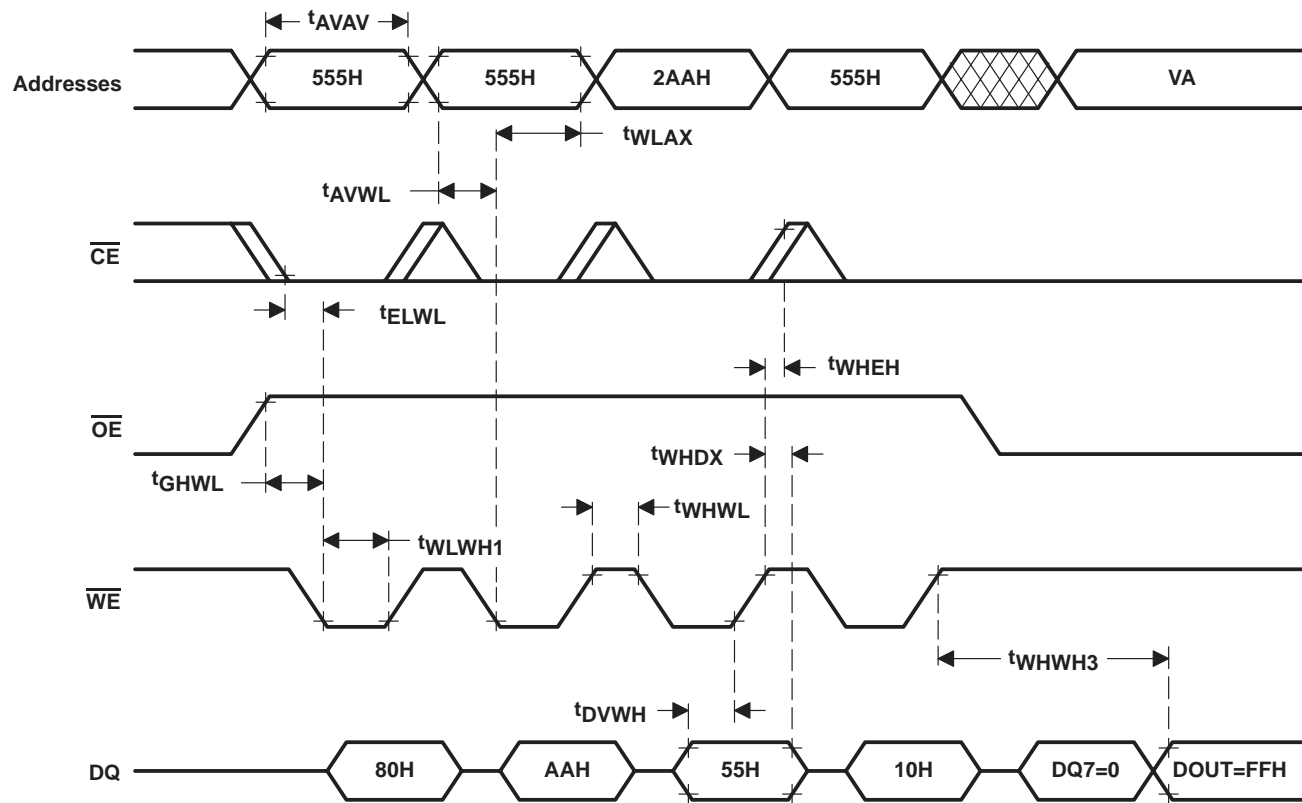

Figure 10. Chip-Erase Algorithm

chip-erase operation (continued)



- NOTES: A. VA = any valid address  
 B. Figure details the last four bus cycles in a six-bus-cycle operation.

Figure 11. AC Waveform for Chip-Erase Operation

PRODUCT PREVIEW

sector-erase operation

PRODUCT PREVIEW

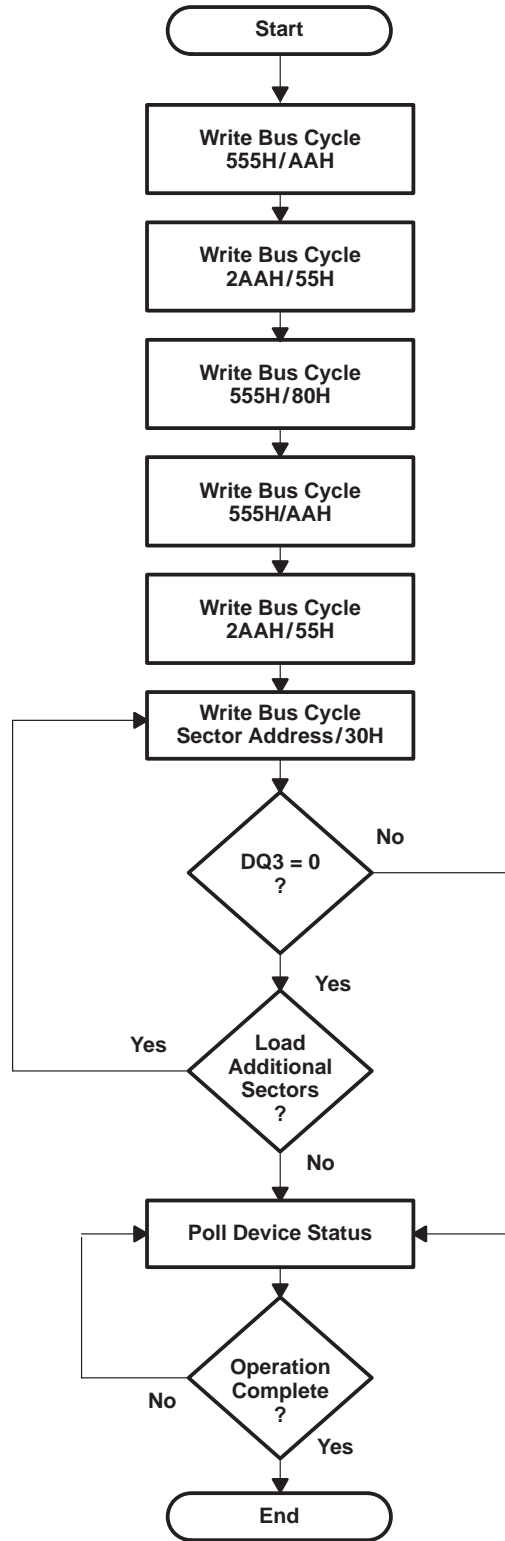
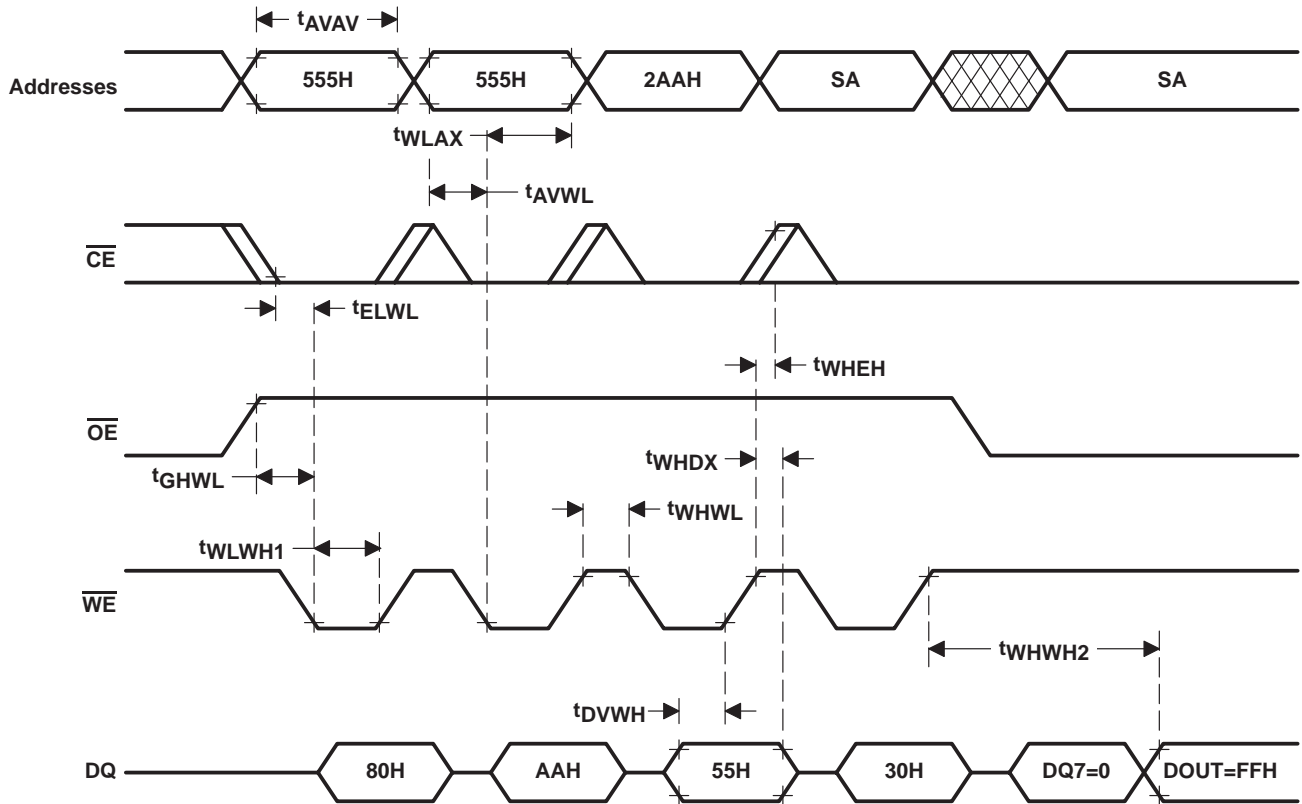

Figure 12. Sector-Erase Algorithm

sector-erase operation (continued)



- NOTES: A. SA = Sector address to be erased  
 B. Figure details the last four bus cycles in a six-bus-cycle operation.

Figure 13. AC Waveform for Sector-Erase Operation

PRODUCT PREVIEW

data-polling operation

PRODUCT PREVIEW

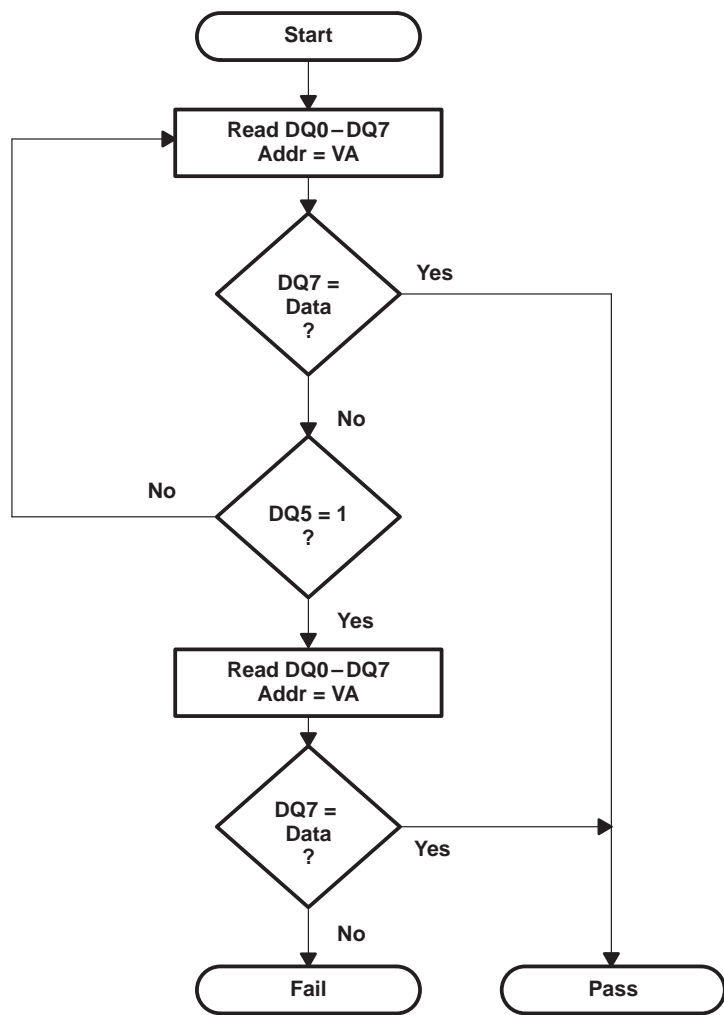

- NOTES: A. Polling status bits DQ7 and DQ5 may change asynchronously.  
 Read DQ7 after DQ5 changes states.  
 B. VA = Program address for byte-programming  
 = Selected sector address for sector erase  
 = Any valid address for chip erase

Figure 14. Data-Polling Algorithm



data-polling operation (continued)

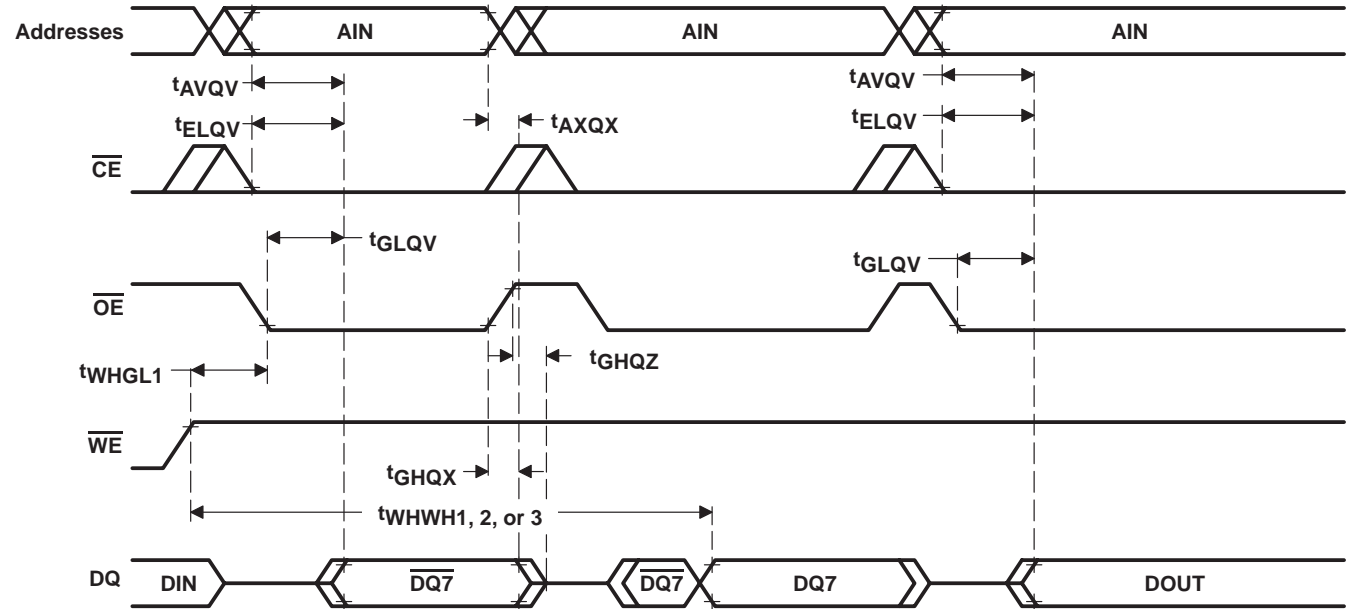

- NOTES: A.  $\overline{\text{DIN}}$  = Last command data written to the device  
 B.  $\overline{\text{DQ7}}$  = Complement of data written to DQ7  
 C. DOUT = Valid data output  
 D. AIN = Valid address for byte-program, sector-erase, or chip-erase operation

Figure 15. AC Waveform for Data-Polling Operation

PRODUCT PREVIEW

toggle-bit operation

PRODUCT PREVIEW

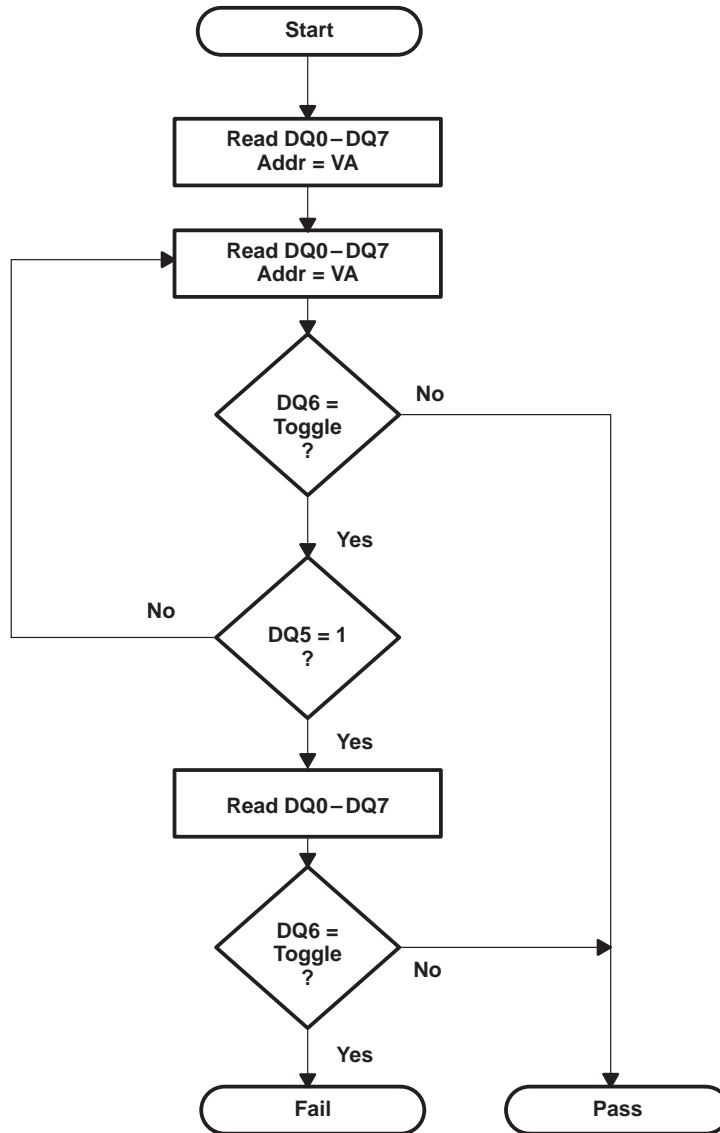

NOTE A: Polling status bits DQ6 and DQ5 can change asynchronously. Read DQ6 after DQ5 changes states.

Figure 16. Toggle-Bit Algorithm

toggle-bit operation (continued)

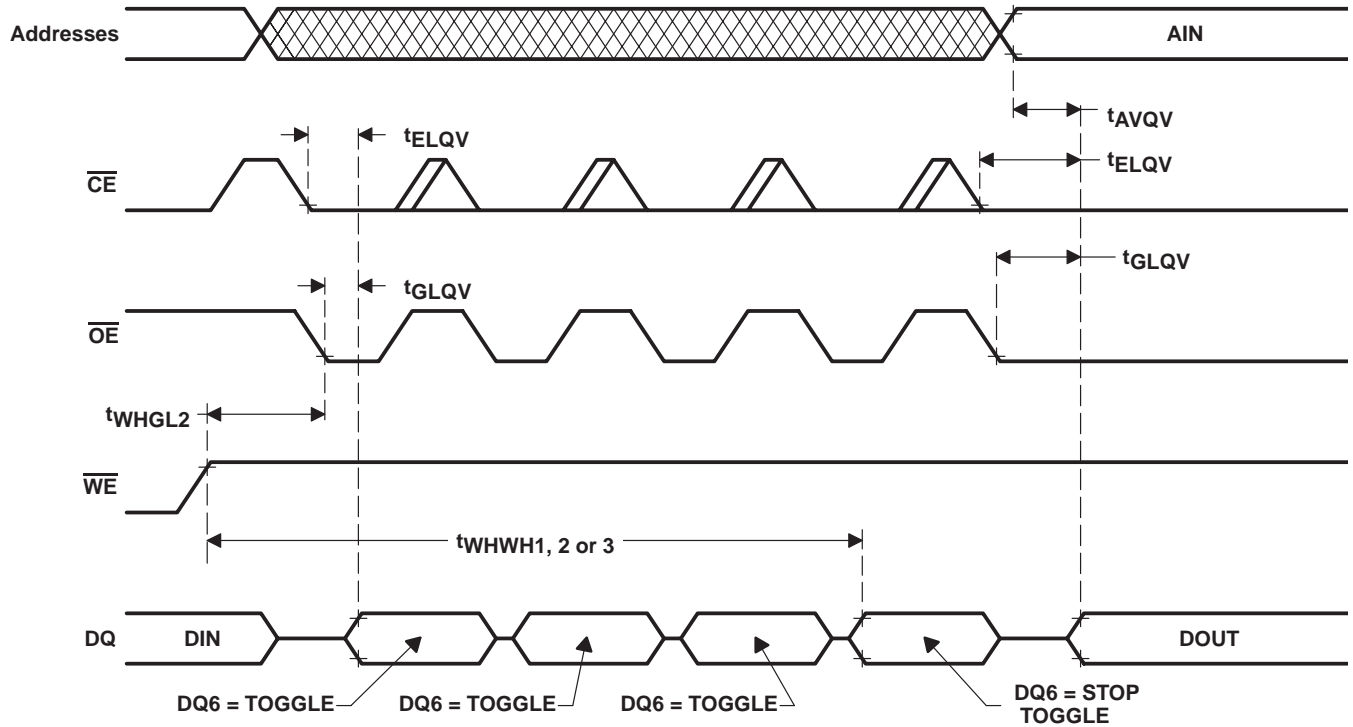

- NOTES: A. DIN = Last command data written to the device  
 B. DQ6 = Toggle bit output  
 C. DOUT = Valid data output  
 D. AIN = Valid address for byte-program, sector-erase, or chip-erase operation

Figure 17. AC Waveforms for Toggle-Bit Operation

PRODUCT PREVIEW

sector-protect operation

PRODUCT PREVIEW

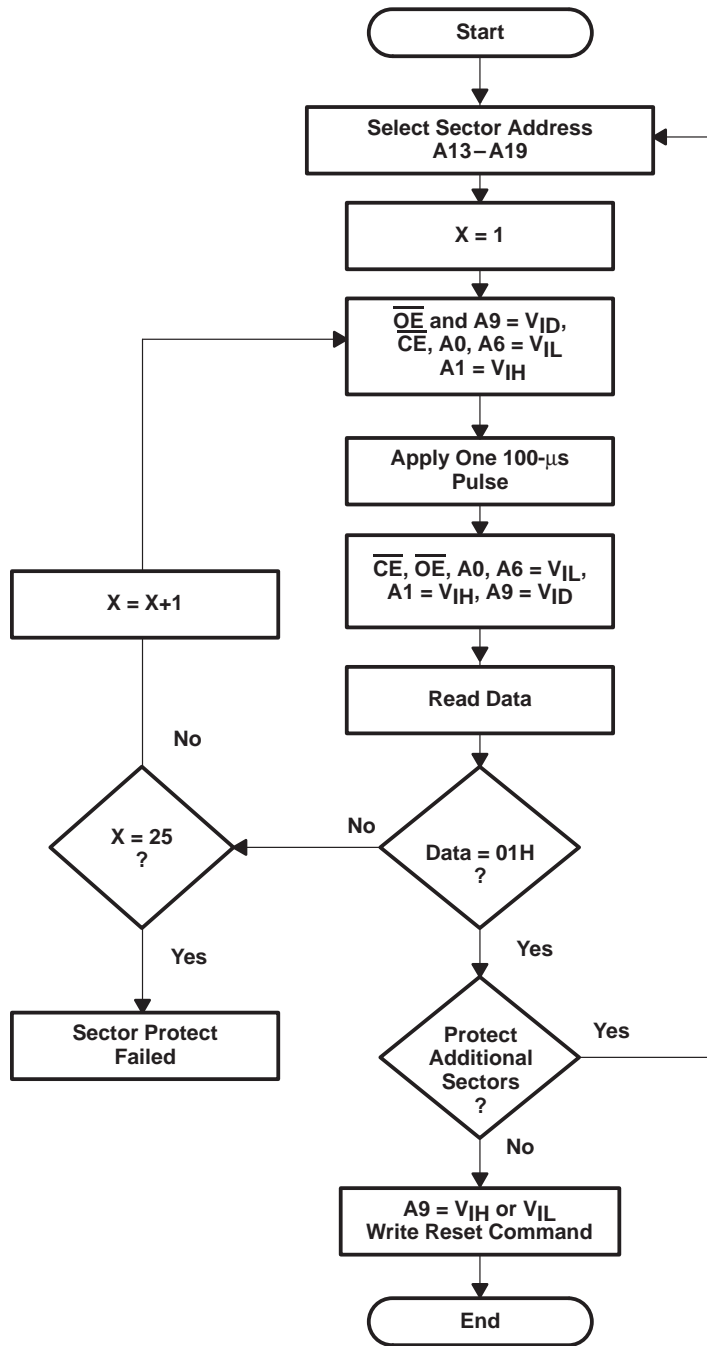
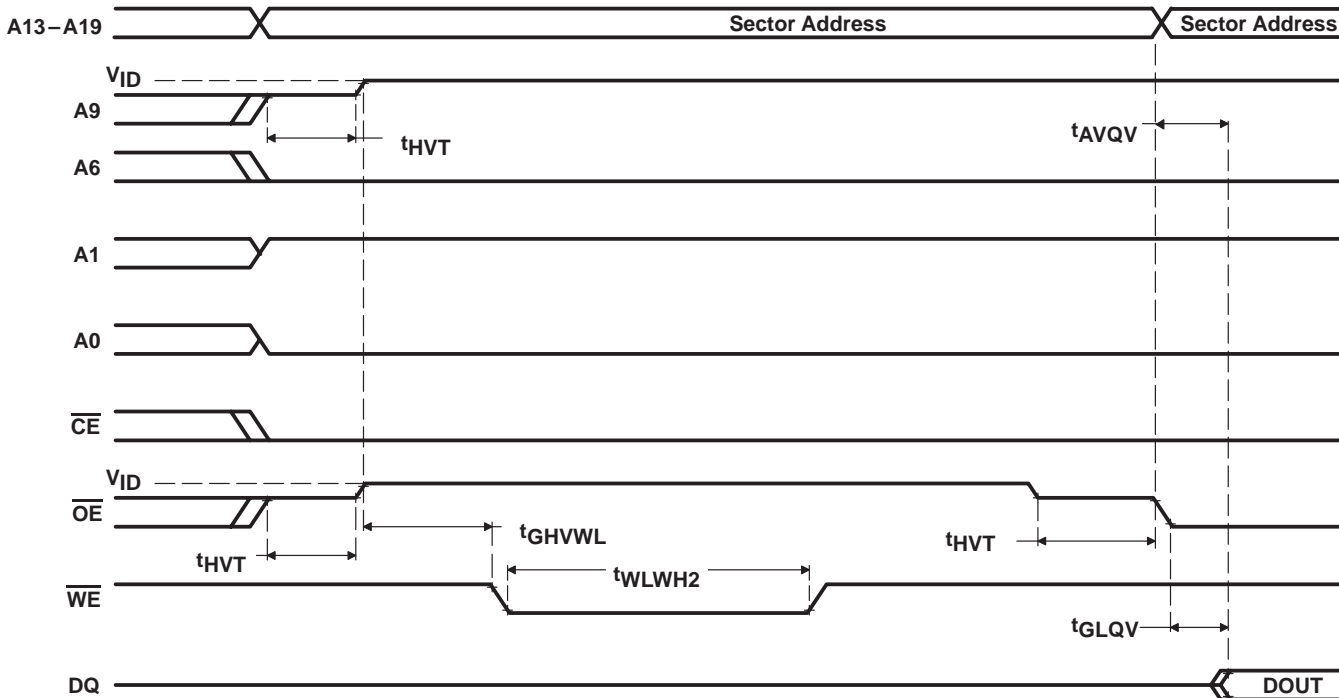

Figure 18. Sector-Protect Algorithm

sector-protect operation (continued)



NOTE A: DOUT = 00H if selected sector is not protected,  
 01H if the sector is protected

Figure 19. AC Waveform for Sector-Protect Operation

PRODUCT PREVIEW

sector-unprotect operation

PRODUCT PREVIEW

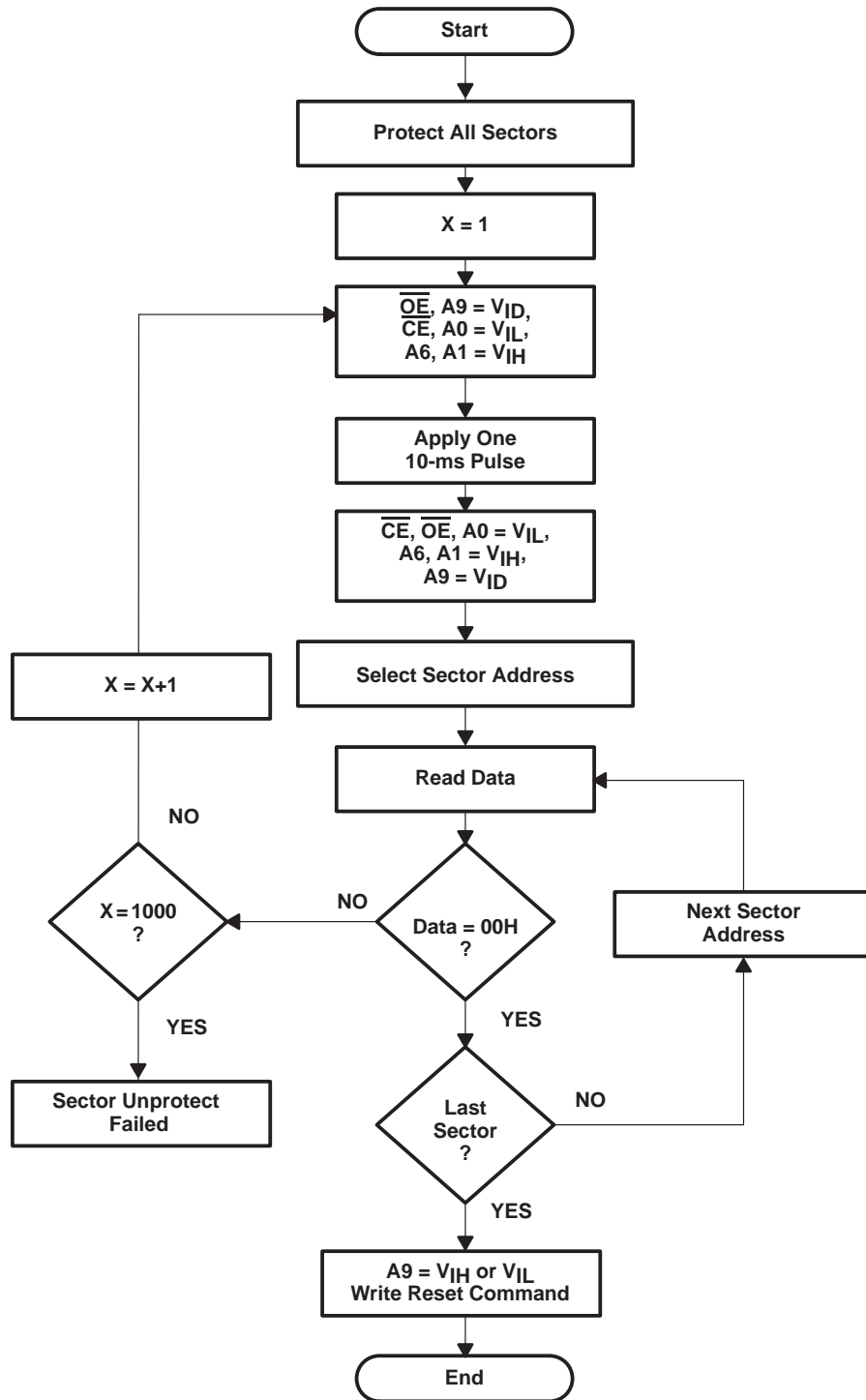
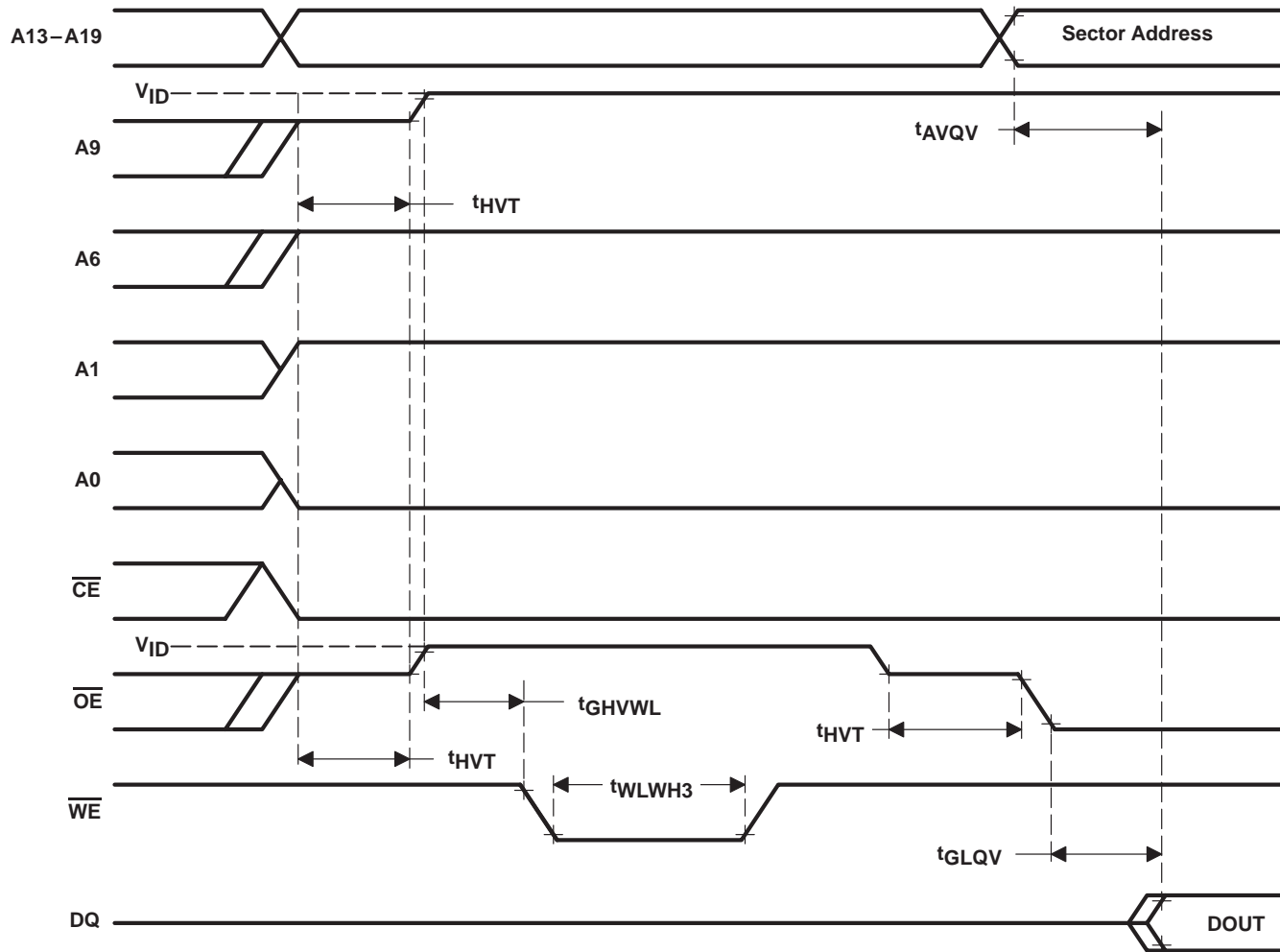

Figure 20. Sector-Unprotect Algorithm

sector-unprotect operation (continued)



NOTE A: DOUT = 00H if selected sector is not protected,  
 01H if the sector is protected

Figure 21. AC Waveform for Sector-Unprotect Operation

PRODUCT PREVIEW

temporary sector-unprotect operation

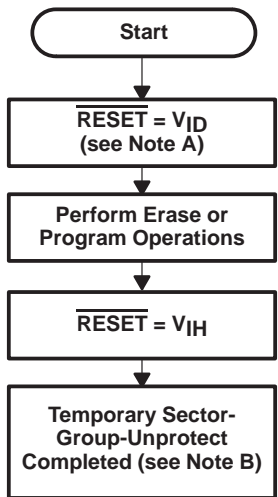

NOTES: A. All protected sectors unprotected  
 B. All previously protected sectors are protected once again

Figure 22. Temporary Sector-Unprotect Algorithm

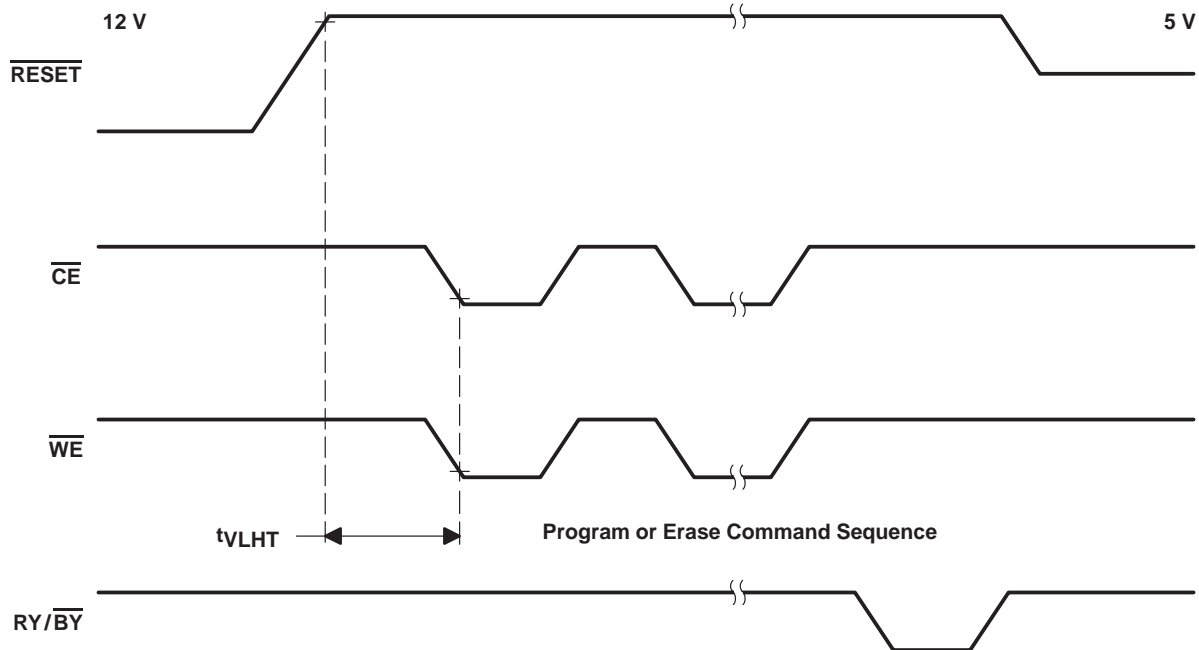

Figure 23. Temporary Sector-Unprotect Timing Diagram

PRODUCT PREVIEW



PARAMETER MEASUREMENT INFORMATION

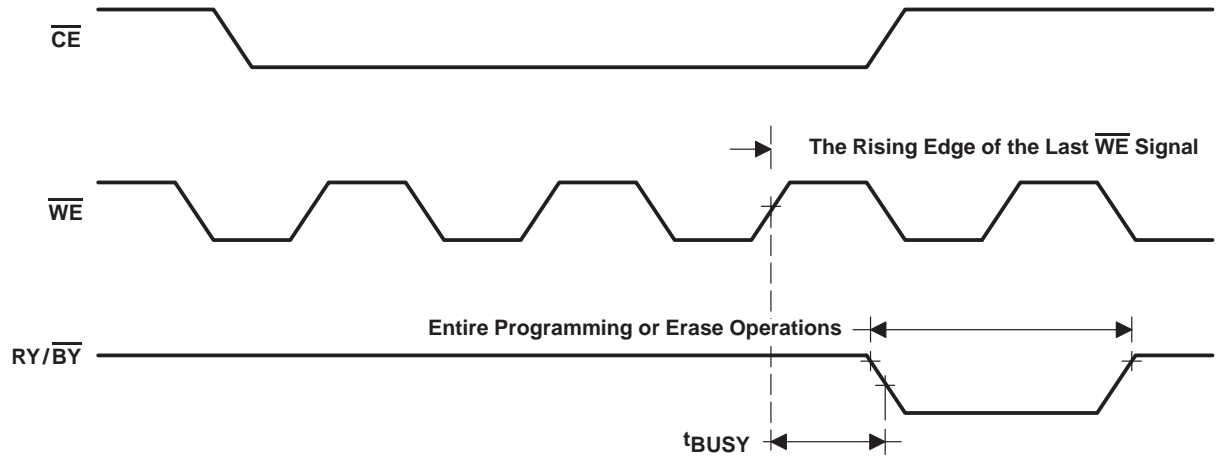

Figure 24.  $RY/\overline{BY}$  Timing Diagram During Program/Erase Operations

TMS29LF008T, TMS29LF008B  
 1048576 BY 8-BIT  
 FLASH MEMORIES

SMJS846A – MAY 1997 – REVISED NOVEMBER 1997

MECHANICAL DATA

DCD (R-PDSO-G\*\*)

PLASTIC DUAL SMALL-OUTLINE PACKAGE

40 PIN SHOWN

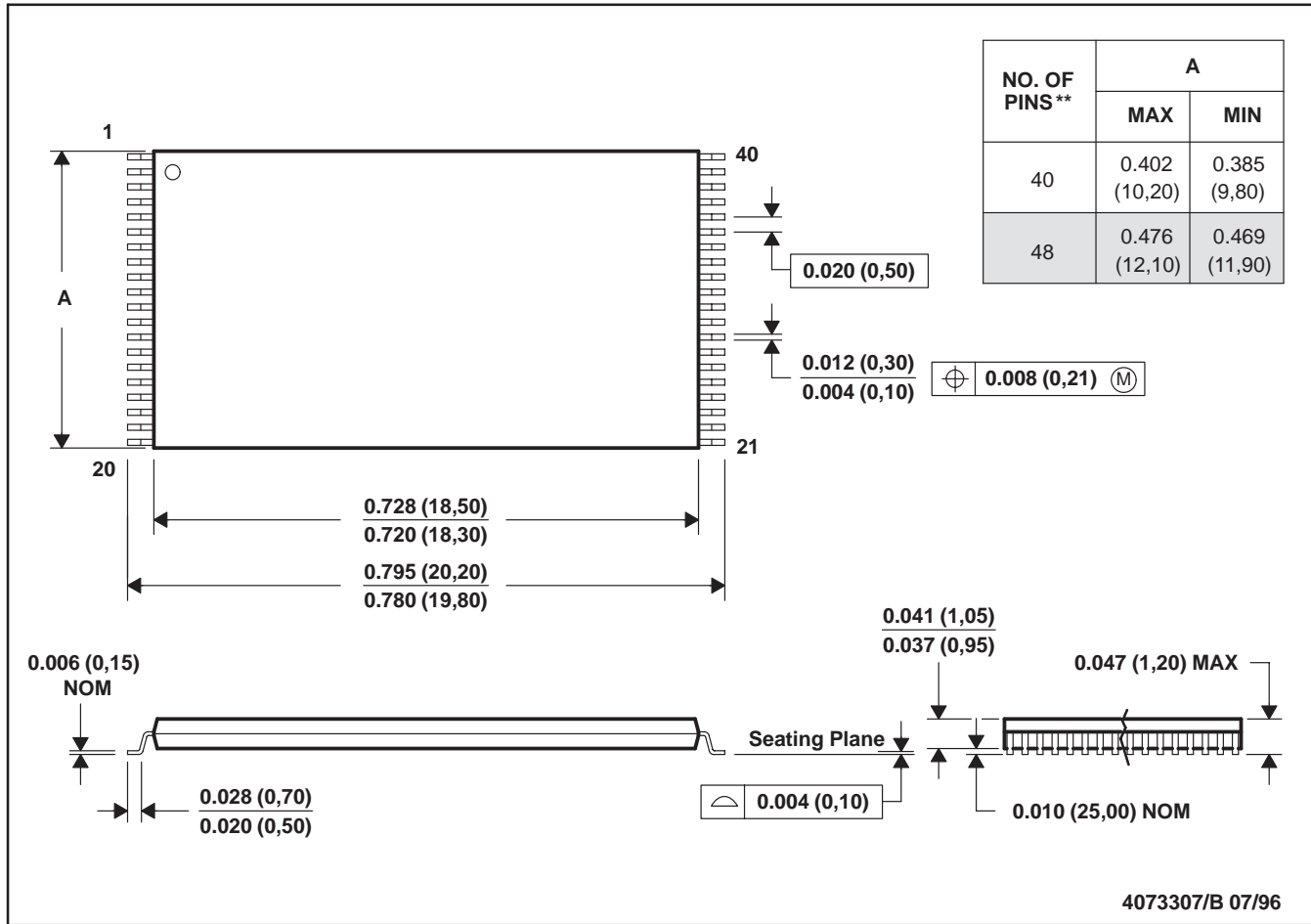

NOTES: A. All linear dimensions are in inches (millimeters).  
 B. This drawing is subject to change without notice.

PRODUCT PREVIEW

## IMPORTANT NOTICE

Texas Instruments and its subsidiaries (TI) reserve the right to make changes to their products or to discontinue any product or service without notice, and advise customers to obtain the latest version of relevant information to verify, before placing orders, that information being relied on is current and complete. All products are sold subject to the terms and conditions of sale supplied at the time of order acknowledgement, including those pertaining to warranty, patent infringement, and limitation of liability.

TI warrants performance of its semiconductor products to the specifications applicable at the time of sale in accordance with TI's standard warranty. Testing and other quality control techniques are utilized to the extent TI deems necessary to support this warranty. Specific testing of all parameters of each device is not necessarily performed, except those mandated by government requirements.

CERTAIN APPLICATIONS USING SEMICONDUCTOR PRODUCTS MAY INVOLVE POTENTIAL RISKS OF DEATH, PERSONAL INJURY, OR SEVERE PROPERTY OR ENVIRONMENTAL DAMAGE ("CRITICAL APPLICATIONS"). TI SEMICONDUCTOR PRODUCTS ARE NOT DESIGNED, AUTHORIZED, OR WARRANTED TO BE SUITABLE FOR USE IN LIFE-SUPPORT DEVICES OR SYSTEMS OR OTHER CRITICAL APPLICATIONS. INCLUSION OF TI PRODUCTS IN SUCH APPLICATIONS IS UNDERSTOOD TO BE FULLY AT THE CUSTOMER'S RISK.

In order to minimize risks associated with the customer's applications, adequate design and operating safeguards must be provided by the customer to minimize inherent or procedural hazards.

TI assumes no liability for applications assistance or customer product design. TI does not warrant or represent that any license, either express or implied, is granted under any patent right, copyright, mask work right, or other intellectual property right of TI covering or relating to any combination, machine, or process in which such semiconductor products or services might be or are used. TI's publication of information regarding any third party's products or services does not constitute TI's approval, warranty or endorsement thereof.