

TRIPLE 3-INPUT AND GATE

FEATURES

- Output capability: standard
- I<sub>CC</sub> category: SSI

GENERAL DESCRIPTION

The 74HC/HCT11 are high-speed Si-gate CMOS devices and are pin compatible with low power Schottky TTL (LSSTTL). They are specified in compliance with JEDEC standard no. 7A. The 74HC/HCT11 provide the 3-input AND function.

SYMBOL	PARAMETER	CONDITIONS	TYPICAL		UNIT
			HC	HCT	
t <sub>PHL</sub> / t <sub>PLH</sub>	propagation delay nA, nB, nC to nY	C <sub>L</sub> = 15 pF V <sub>CC</sub> = 5 V	10	11	ns
C <sub>I</sub>	input capacitance		3.5	3.5	pF
C <sub>PD</sub>	power dissipation capacitance per gate	notes 1 and 2	18	20	pF

GND = 0 V; T<sub>amb</sub> = 25 °C; t<sub>r</sub> = t<sub>f</sub> = 6 ns

Notes

1. C<sub>PD</sub> is used to determine the dynamic power dissipation (P<sub>D</sub> in μW):

$$P_D = C_{PD} \times V_{CC}^2 \times f_i + \sum (C_L \times V_{CC}^2 \times f_o) \text{ where:}$$

f<sub>i</sub> = input frequency in MHz                      C<sub>L</sub> = output load capacitance in pF  
 f<sub>o</sub> = output frequency in MHz                    V<sub>CC</sub> = supply voltage in V  
 Σ (C<sub>L</sub> × V<sub>CC</sub><sup>2</sup> × f<sub>o</sub>) = sum of outputs

2. For HC the condition is V<sub>I</sub> = GND to V<sub>CC</sub>  
 For HCT the condition is V<sub>I</sub> = GND to V<sub>CC</sub> - 1.5 V

PACKAGE OUTLINES

SEE PACKAGE INFORMATION SECTION

PIN DESCRIPTION

PIN NO.	SYMBOL	NAME AND FUNCTION
1, 3, 9	1A to 3A	data inputs
2, 4, 10	1B to 3B	data inputs
7	GND	ground (0 V)
12, 6, 8	1Y to 3Y	data outputs
13, 5, 11	1C to 3C	data inputs
14	V <sub>CC</sub>	positive supply voltage

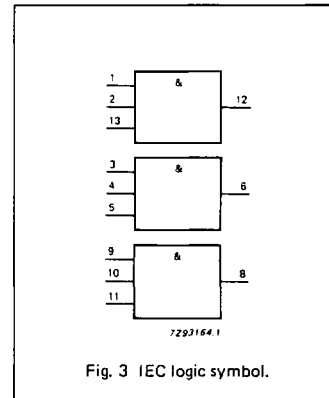
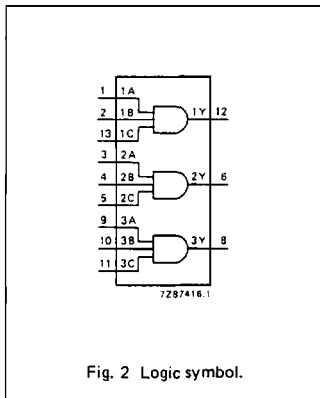
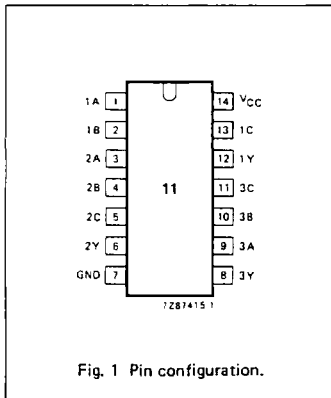

74HC/HCT11  
SSI

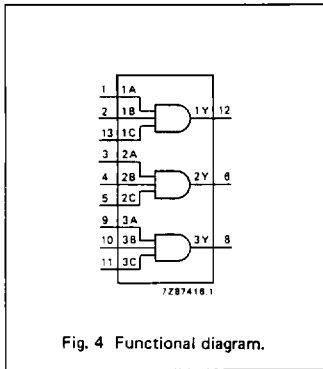

Fig. 4 Functional diagram.

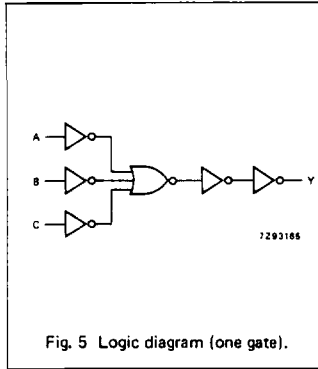

Fig. 5 Logic diagram (one gate).

FUNCTION TABLE

INPUTS			OUTPUT
nA	nB	nC	nY
L	L	L	L
L	L	H	L
L	H	L	L
L	H	H	L
H	L	L	L
H	L	H	L
H	H	L	L
H	H	H	H

H = HIGH voltage level  
L = LOW voltage level

DC CHARACTERISTICS FOR 74HC

For the DC characteristics see chapter "HCMOS family characteristics", section "Family specifications"

Output capability: standard

I<sub>CC</sub> category: SSI

AC CHARACTERISTICS FOR 74HC

GND = 0 V; t<sub>r</sub> = t<sub>f</sub> = 6 ns; C<sub>L</sub> = 50 pF

SYMBOL	PARAMETER	T <sub>amb</sub> (°C)						UNIT	TEST CONDITIONS		
		74HC							V <sub>CC</sub> V	WAVEFORMS	
		+25			-40 to +85		-40 to +125				
		min.	typ.	max.	min.	max.	min.				max.
t <sub>PHL</sub> / t <sub>PLH</sub>	propagation delay nA, nB, nC to nY		32 12 10	100 20 17		125 25 21		150 30 26	ns	2.0 4.5 6.0	Fig. 6
t <sub>THL</sub> / t <sub>TLH</sub>	output transition times		19 7 6	75 15 13		95 19 16		110 22 19	ns	2.0 4.5 6.0	Fig. 6

**DC CHARACTERISTICS FOR 74HCT**

For the DC characteristics see chapter "HCMOS family characteristics", section "Family specifications".

Output capability: standard

$I_{CC}$  category: SSI

Note to HCT types

The value of additional quiescent supply current ( $\Delta I_{CC}$ ) for a unit load of 1 is given in the family specifications. To determine  $\Delta I_{CC}$  per input, multiply this value by the unit load coefficient shown in the table below.

INPUT	UNIT LOAD COEFFICIENT
nA, nB, nC	1.00

**AC CHARACTERISTICS FOR 74HCT**

GND = 0 V;  $t_r = t_f = 6$  ns;  $C_L = 50$  pF

SYMBOL	PARAMETER	$T_{amb}$ (°C)						UNIT	TEST CONDITIONS		
		74HCT							$V_{CC}$ V	WAVEFORMS	
		+25			-40 to +85		-40 to +125				
		min.	typ.	max.	min.	max.	min.				max.
$t_{PHL}/t_{PLH}$	propagation delay nA, nB, nC to nY		16	24		30		36	ns	4.5	Fig. 6
$t_{THL}/t_{TLH}$	output transition times		7	15		19		22	ns	4.5	Fig. 6

AC WAVEFORMS

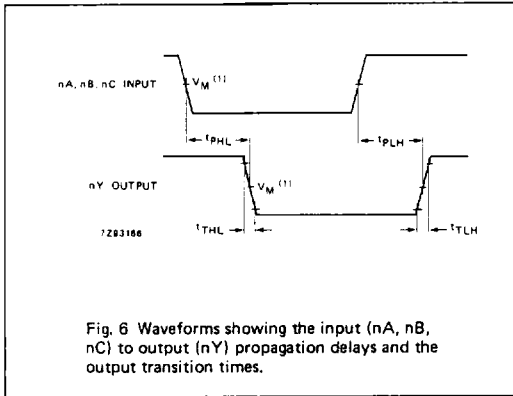

Fig. 6 Waveforms showing the input (nA, nB, nC) to output (nY) propagation delays and the output transition times.

Note to AC waveforms

- (1) HC :  $V_M = 50\%$ ;  $V_I = \text{GND to } V_{CC}$ .
- HCT:  $V_M = 1.3\text{ V}$ ;  $V_I = \text{GND to } 3\text{ V}$ .