

Date Sheet 2837,Rev.-

Features

- Schottky Barrier chip
- Guard Ring Die Construction
- Low Profile Package
- High Surge Current Capability
- Low Power Loss, High Efficiency
- Ideal for Printed Circuit Board
- For Use in Low Voltage, High Frequency Inverters, Free Wheeling Applications

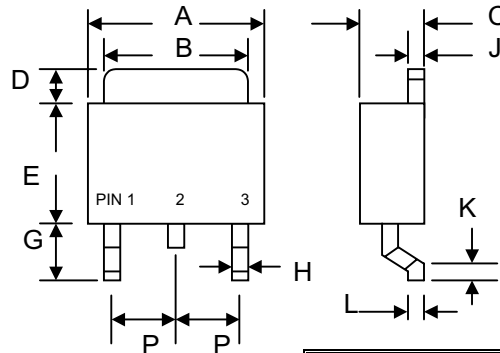

Mechanical Data

- Case: Molded Plastic
- Terminals: Plated Leads Solderable per MIL-STD-750, Method 2026
- Polarity: Cathode Band
- Weight: 0.4 grams (approx.)
- Mounting Position: Any
- Marking: Type Number
- Standard Packaging: 16mm Tape (EIA-481)

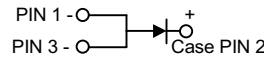

D-PAK/TO-252AA				
Dim	Min	Max	Min	Max
A	6.40	6.80	0.252	0.268
B	5.00	5.40	0.197	0.213
C	2.35	2.75	0.093	0.108
D	—	1.60	—	0.063
E	5.30	5.70	0.209	0.224
G	2.30	2.70	0.091	0.106
H	0.40	0.80	0.016	0.031
J	0.40	0.60	0.016	0.024
K	0.30	0.70	0.012	0.028
L	0.50 Typical		0.020 Typical	
P	—	2.30	—	0.091
			In mm	In inch

Maximum Ratings and Electrical Characteristics @T_A=25°C unless otherwise specified

Single Phase, half wave, 60Hz, resistive or inductive load. For capacitive load, derate current by 20%.

Characteristic	Symbol	SD 520YS	SD 530YS	SD 540YS	SD 550YS	SD 560YS	SD 580YS	SD 5100YS	Unit
Peak Repetitive Reverse Voltage	V _{RRM}	20	30	40	50	60	80	100	V
Working Peak Reverse Voltage	V _{RWM}								
DC Blocking Voltage	V _R								
RMS Reverse Voltage	V _{R(RMS)}	14	21	28	35	42	56	70	V
Average Rectified Output Current @T _L = 75°C	I _O	5.0							A
Non-Repetitive Peak Forward Surge Current 8.3ms Single half sine-wave superimposed on rated load (JEDEC Method)	I _{FSM}	100							A
Forward Voltage (Note 1) @I _F = 5.0A	V _{FM}	0.55			0.75		0.85		V
Peak Reverse Current @T _A = 25°C At Rated DC Blocking Voltage @T _A = 100°C	I _{RM}	0.2 20							mA
Typical Junction Capacitance (Note 2)	C _j	400							pF
Typical Thermal Resistance Junction to Ambient	R _{θJA}	50							K/W
Operating Temperature Range	T _j	-50 to +125							°C
Storage Temperature Range	T _{STG}	-50 to +150							°C

Note: 1. Mounted on P.C. Board with 14mm² (0.13mm thick) copper pad.
2. Measured at 1.0 MHz and applied reverse voltage of 4.0V D.C.

Data Sheet 2837, Rev. -

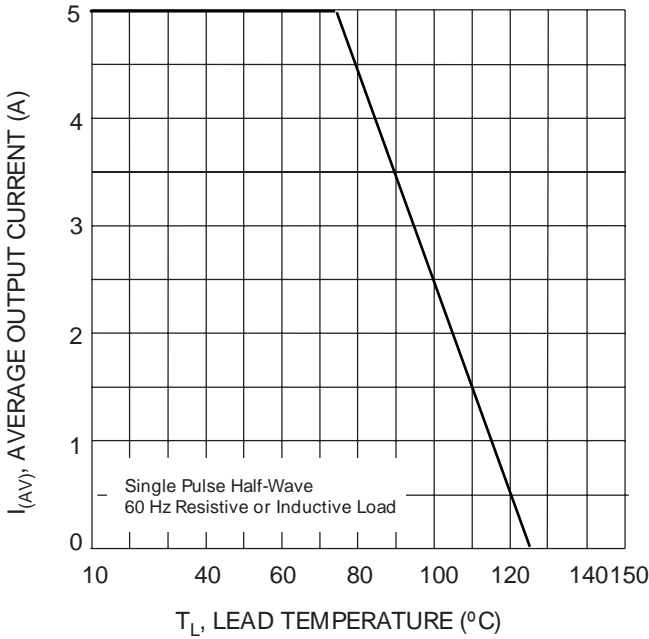

Fig. 1 Forward Current Derating Curve

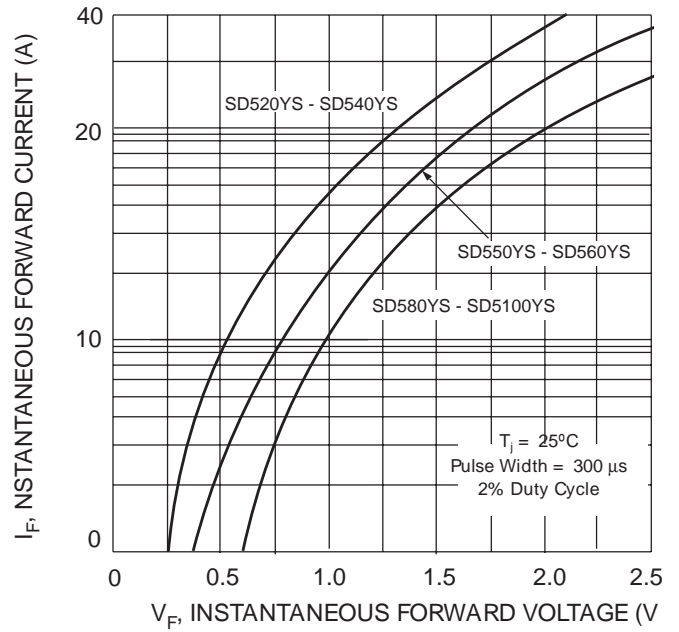

Fig. 2 Typical Forward Characteristics

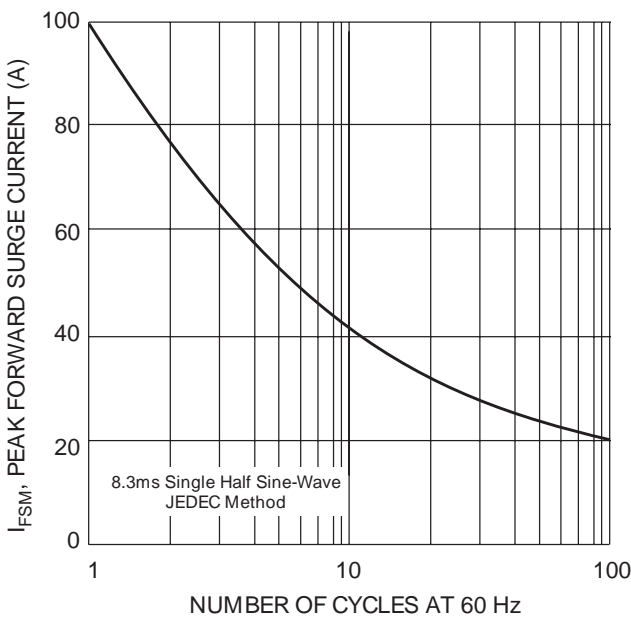

Fig. 3 Maximum Non-Repetitive Peak Fwd Surge Current

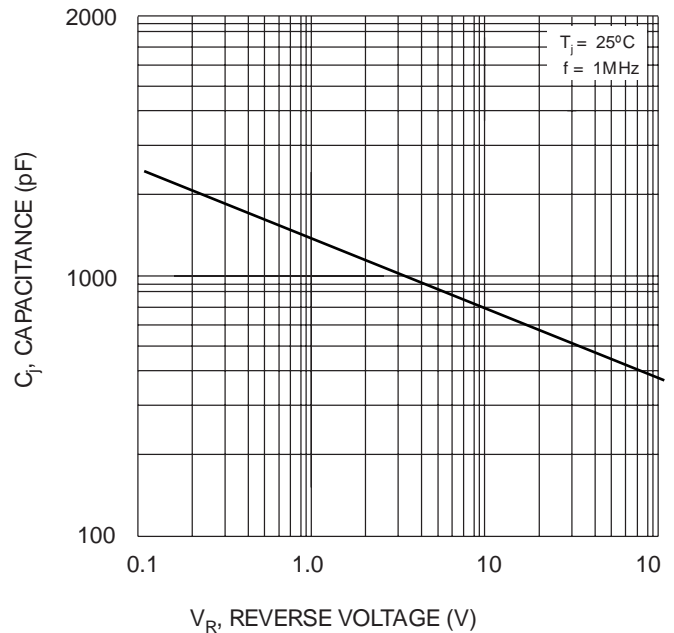

Fig. 4 Typical Junction Capacitance