

## 1.5A Low Dropout Fast Response Positive Adjustable Regulator and Fixed 1.8V, 2.5V, 2.85V and 3.3V

### Features

- Guaranteed Output Voltage Accuracy within 2%
- Fast Transient Response
- Guaranteed Dropout Voltage at Multiple Currents
- Load Regulation : 0.1% Typ.
- Line Regulation : 0.03% Typ.
- Low Dropout Voltage : 1.3V Typ. at  $I_{OUT}=1.5A$
- Current Limit : 1.5A Min. at  $T_J=125^{\circ}C$
- On-Chip Thermal Limiting : 150 °C Typ.
- Adjustable Output : 1.25~10.7V
- Standard 3-pin SOT-223, TO-252 , TO-220 and TO-263 Power Packages
- Lead Free Available (RoHS Compliant)

### Applications

- Active SCSI Terminators
- Low Voltage Logic Supplies
- Battery-Powered Circuitry
- Post Regulator for Switching Power Supply

### Pin Description

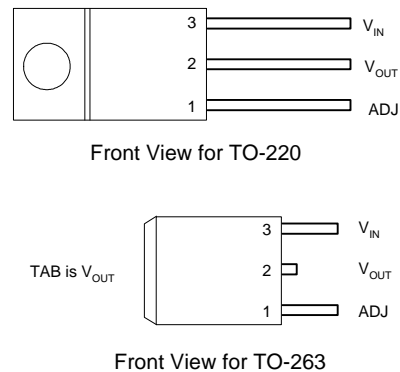
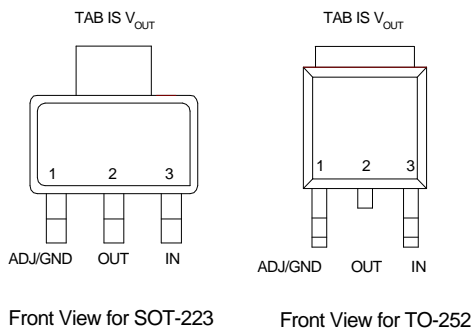

### General Description

The APL1086 is a low dropout three-terminal adjustable regulators with 1.5A output current capability. In order to obtain lower dropout voltage and faster transient response, which is critical for low voltage applications, the APL1086 has been optimized.







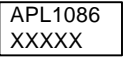

The device is available in an adjustable version and fixed output voltages of 1.8V, 2.5V, 2.85V and 3.3V, the output available voltage range is from 1.25~10.7V with an input supply below 12V. Dropout voltage is guaranteed at a maximum of 1.45V at 1.5A.

Current limit is trimmed to ensure specified output current and controlled short-circuit current. On-chip thermal limiting provides protection against any combination of overload that would create excessive junction temperatures.

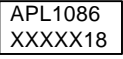
The APL1086 is available in the industry standard 3-pin SOT-223, TO-252, TO-220 or TO-263 power packages.

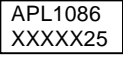
ANPEC reserves the right to make changes to improve reliability or manufacturability without notice, and advise customers to obtain the latest version of relevant information to verify before placing orders.

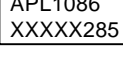
## Ordering and Marking Information

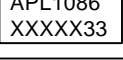
<p>APL1086- □□ □□ - □□□□</p> <p>Lead Free Code Handling Code Temp. Range Package Code Voltage Code</p>	<p>Package Code F : TO-220      G : TO-263 U : TO-252      V : SOT-223</p> <p>Temp. Range C : 0 to 70 °C</p> <p>Handling Code TU : Tube      TR : Tape &amp; Reel</p> <p>Voltage Code 18 : 1.8V      25 : 2.5V      285 : 2.85V      33 : 3.3V Blank : Adjustable Version</p> <p>Lead Free Code L : Lead Free Device      Blank : Original Device</p>
APL1086 F/G/U :  XXXXX - Date Code	APL1086 V :  XXXXX - Date Code
APL1086 -18F/G/U:  XXXXX - Date Code	APL1086- 18V :  XXXXX - Date Code
APL1086 -25F/G/U:  XXXXX - Date Code	APL1086- 25V :  XXXXX - Date Code
APL1086 -285F/G/U:  XXXXX - Date Code	APL1086- 285V :  XXXXX - Date Code
APL1086 -33F/G/U:  XXXXX - Date Code	APL1086- 33V :  XXXXX - Date Code

Note: ANPEC lead-free products contain molding compounds/die attach materials and 100% matte tin plate termination finish; which are fully compliant with RoHS and compatible with both SnPb and lead-free soldering operations. ANPEC lead-free products meet or exceed the lead-free requirements of IPC/JEDEC J STD-020C for MSL classification at lead-free peak reflow temperature.

## Absolute Maximum Ratings

Symbol	Parameter	Rating	Unit
V <sub>I</sub>	Input Voltage	15	V
P <sub>D</sub>	Power Dissipation, T <sub>A</sub> =25°C SOT-223 TO-252	1.7 2	W
θ <sub>JA</sub>	Thermal Resistance from Junction to Ambient in Free Air SOT-223 TO-252	60 50	°C/W
T <sub>J</sub>	Operating Junction Temperature Range	0 to 150	°C
T <sub>STG</sub>	Storage Temperature Range	-65 to +150	°C
T <sub>L</sub>	Lead Temperature (Soldering, 10 second)	260	°C

Note 1: Stresses beyond the absolute maximum rating may damage the device and operating in the absolute maximum rating conditions may affect device reliability.

Note 2: The maximum allowable power dissipation at any T<sub>A</sub> (ambient temperature) is calculated using: P<sub>D</sub> (max) = (T<sub>J</sub> - T<sub>A</sub>) / θ<sub>JA</sub>; T<sub>J</sub> = 125°C. Exceeding the maximum allowable power dissipation will result in excessive die temperature.

Electrical Characteristics

Symbol	Parameter	Test Conditions	APL1086			Unit
			Min.	Typ.	Max.	
V <sub>REF</sub>	Reference Voltage	10mA ≤ I <sub>OUT</sub> ≤ 1.5A, 1.4V ≤ (V <sub>IN</sub> - V <sub>OUT</sub> ) ≤ 9.75V, T <sub>J</sub> = 0~125°C	1.225	1.250	1.275	V
V <sub>OUT</sub>	Output Voltage					V
	APL1086-18	T <sub>J</sub> = 25°C, I <sub>OUT</sub> = 0mA, T <sub>J</sub> = 0~125°C, 0 ≤ I <sub>OUT</sub> ≤ 1.5A, 3.5V ≤ V <sub>IN</sub> ≤ 9V,	1.782 1.764	1.800 1.800	1.818 1.836	
	APL1086-25	T <sub>J</sub> = 25°C, I <sub>OUT</sub> = 0mA, T <sub>J</sub> = 0~125°C, 0 ≤ I <sub>OUT</sub> ≤ 1.5A, 4V ≤ V <sub>IN</sub> ≤ 9V,	2.475 2.450	2.500 2.500	2.525 2.550	
	APL1086-28	T <sub>J</sub> = 25°C, I <sub>OUT</sub> = 0mA, T <sub>J</sub> = 0~125°C, 0 ≤ I <sub>OUT</sub> ≤ 1.5A, 4.25V ≤ V <sub>IN</sub> ≤ 9V,	2.822 2.792	2.850 2.850	2.878 2.910	
APL1086-33	T <sub>J</sub> = 25°C, I <sub>OUT</sub> = 0mA, T <sub>J</sub> = 0~125°C, 0 ≤ I <sub>OUT</sub> ≤ 1.5A, 4.75V ≤ V <sub>IN</sub> ≤ 9V,	3.267 3.235	3.3003 .300	3.333 3.365		
REG <sub>LINE</sub>	Line Regulation	T <sub>J</sub> = 0~125°C				%
	APL1086	I <sub>OUT</sub> = 10mA, 1.5V ≤ V <sub>IN</sub> - V <sub>OUT</sub> ≤ 9V (note1)		0.03	0.2	
	APL1086-18	I <sub>OUT</sub> = 0mA, 3.5V ≤ V <sub>IN</sub> ≤ 9V (note1)		1	6	
	APL1086-25	I <sub>OUT</sub> = 0A, 4V ≤ V <sub>IN</sub> ≤ 9V (note1)		1	6	
	APL1086-28	I <sub>OUT</sub> = 0A, 4.25V ≤ V <sub>IN</sub> ≤ 9V (note1)		1	6	
APL1086-33	I <sub>OUT</sub> = 0A, 4.75V ≤ V <sub>IN</sub> ≤ 9V (note1)		1	6		
REG <sub>LOAD</sub>	Load Regulation	T <sub>J</sub> = 0~125°C				%
	APL1086	(V <sub>IN</sub> - V <sub>OUT</sub> ) = 3V, 0 ≤ I <sub>OUT</sub> ≤ 1.5A (note1)		0.1	0.4	
	APL1086-18	V <sub>IN</sub> = 3.5V, 0 ≤ I <sub>OUT</sub> ≤ 1.5A (note1)		1	10	
	APL1086-25	V <sub>IN</sub> = 4V, 0 ≤ I <sub>OUT</sub> ≤ 1.5A (note1)		1	10	
	APL1086-28	V <sub>IN</sub> = 4.25V, 0 ≤ I <sub>OUT</sub> ≤ 1.5A (note1)		1	10	
APL1086-33	V <sub>IN</sub> = 4.75V, 0 ≤ I <sub>OUT</sub> ≤ 1.5A (note1)		1	10		
V <sub>D</sub>	Dropout Voltage	I <sub>OUT</sub> = 1.5A, T <sub>J</sub> = 0~125°C (note2)		1.3	1.45	V
I <sub>LIMIT</sub>	Current Limit	(V <sub>IN</sub> - V <sub>OUT</sub> ) = 5V, T <sub>J</sub> = 25°C	1500			mA
I <sub>ADJ</sub>	Adjust Pin Current	(V <sub>IN</sub> - V <sub>OUT</sub> ) = 3V, I <sub>OUT</sub> = 10mA, T <sub>J</sub> = 0~125°C		60	120	μA
ΔI <sub>ADJ</sub>	Adjust Pin Current Change	T <sub>J</sub> = 0~125°C, 10mA ≤ I <sub>OUT</sub> ≤ 1.5A, 1.4V ≤ (V <sub>IN</sub> - V <sub>OUT</sub> ) ≤ 7.75V		0.2	5	μA
I <sub>O</sub>	Minimum Load Current	T <sub>J</sub> = 0~125°C, (V <sub>IN</sub> - V <sub>OUT</sub> ) = 7.75V, (note 3)		1.7		mA
PSRR	Ripple Rejection	F <sub>RIPPLE</sub> = 120Hz, V <sub>RIPPLE</sub> = 1V <sub>P-P</sub> , (V <sub>IN</sub> - V <sub>OUT</sub> ) = 3V, T <sub>J</sub> = 0~125°C	60	75		dB
T <sub>R</sub>	Thermal Regulation	T <sub>J</sub> = 25°C, 30ms Pulse		0.01	0.02	%/W
T <sub>S</sub>	Temperature Stability			0.5		%
L <sub>S</sub>	Long -Term Stability	T <sub>J</sub> = 125°C, 1000Hrs.		0.3		%

## Electrical Characteristics (Cont.)

Symbol	Parameter	Test Conditions	APL1086			Unit
			Min.	Typ.	Max.	
$V_N$	RMS Output Noise	$T_J=25^{\circ}\text{C}, 10\text{Hz} \leq F \leq 10\text{kHz}, (\% \text{ of } V_{\text{OUT}})$		0.003		%
$\theta_{\text{JC}}$	Thermal Resistance from Junction to Case	at Tab, SOT-223		15		$^{\circ}\text{C}/\text{W}$
		at Tab, TO-252		6		
OT	Over Temperature Point			150		$^{\circ}\text{C}$
	Quiescent Current	$T_J=0\sim 125^{\circ}\text{C}, V_{\text{IN}} \leq 9\text{V}$				mA
	APL1086-18	$V_{\text{IN}} \leq 9\text{V}$		5.5	10	
	APL1086-25	$V_{\text{IN}} \leq 9\text{V}$		5.5	10	
	APL1086-28	$V_{\text{IN}} \leq 9\text{V}$		5.5	10	
	APL1086-33	$V_{\text{IN}} \leq 9\text{V}$		5.5	10	

Note 1: See thermal regulation specifications for changes in output voltage due to heating effects. Load line regulations are measured at a constant junction temperature by low duty cycle pulse testing.

Note 2: Dropout voltage is specified over the full output current range of the device. Dropout voltage is defined as the minimum input/output differential measured at the specified output current. Test points and limits are also shown on the Dropout Voltage curve.

Note 3: Minimum load current is defined as the minimum output current required to maintain regulation.

## Application Circuits

1.25V to 10.7V Adjustable Regulator

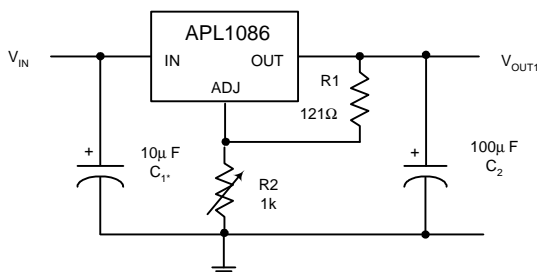

\* Needed if device is far from filter capacitors

$$V_{\text{OUT}} = 1.250\text{V} \times \frac{R1 + R2}{R1}$$

Improving Ripple Rejection

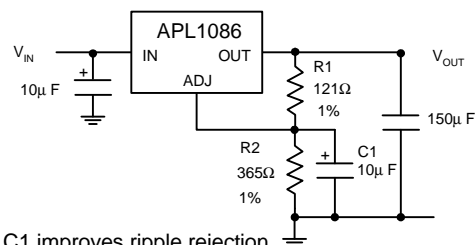

\* C1 improves ripple rejection.  
X<sub>C</sub> should be approximately equal to R1 at ripple frequency

5V Regulator with Shutdown

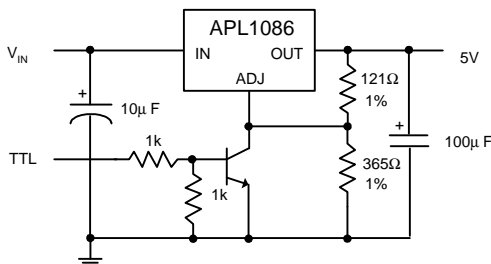

## Typical Characteristics

Load Transient Response

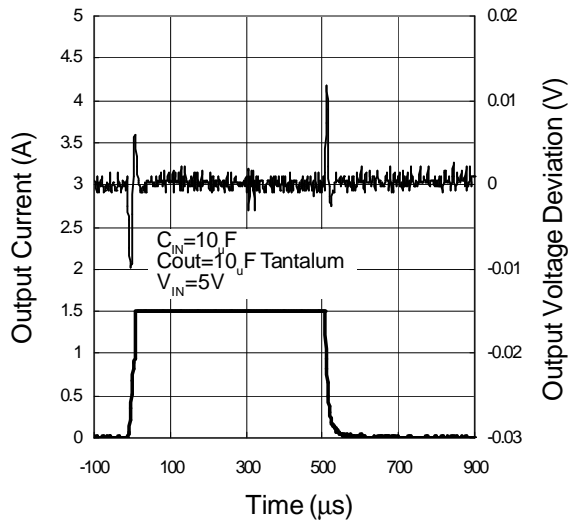

Line Transient Response

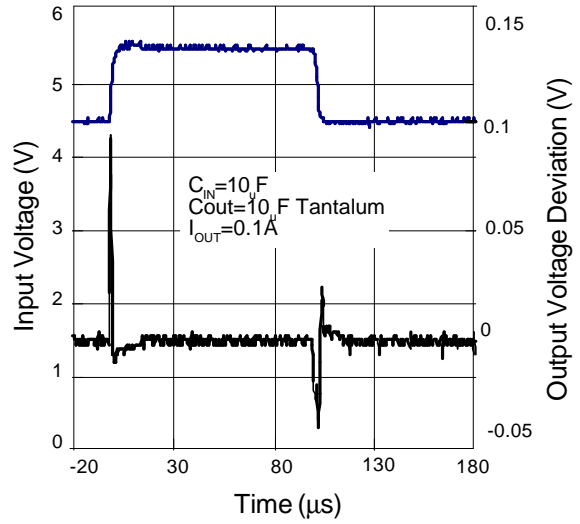

Dropout Voltage vs. Output Current

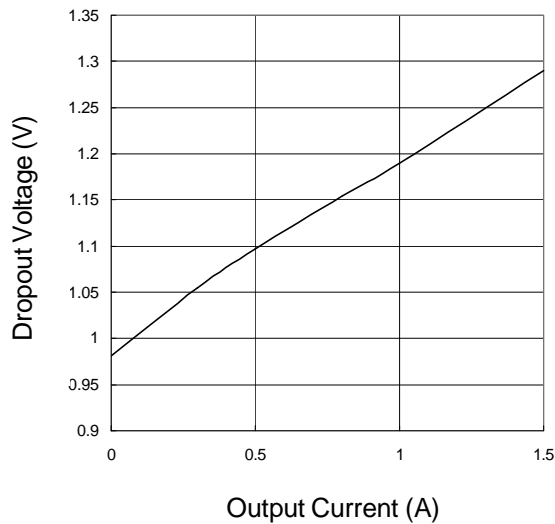

Output Voltage vs. Input Voltage

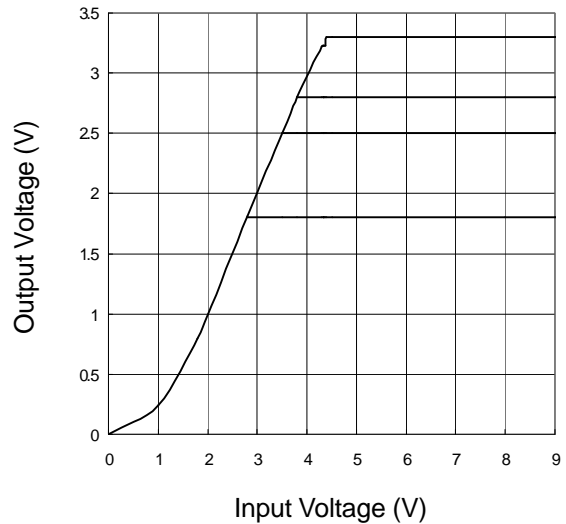

Typical Characteristics (Cont.)

Input Current vs. Input Voltage

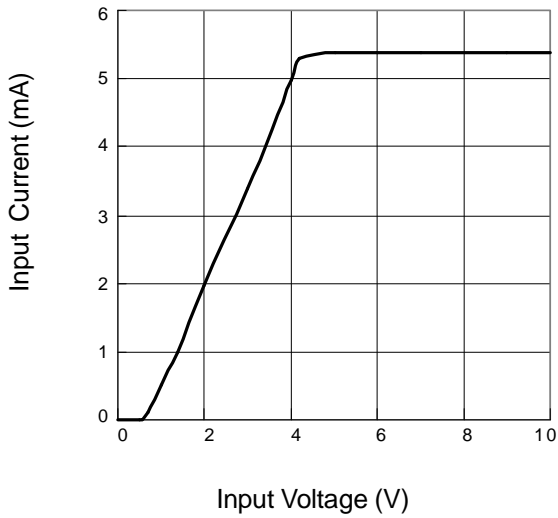

Current Limit vs. Input Voltage

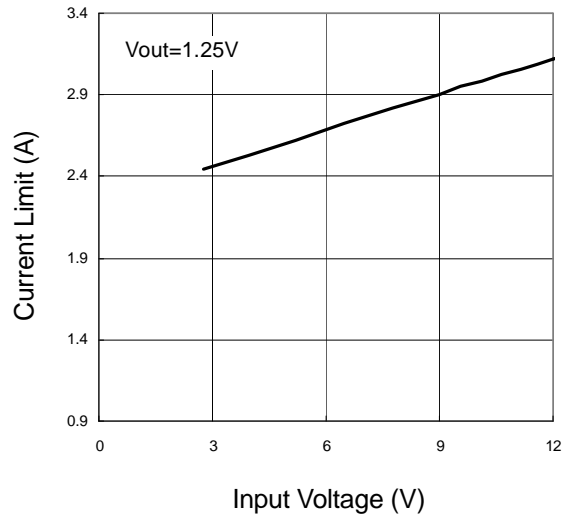

Output Voltage vs. Temperature

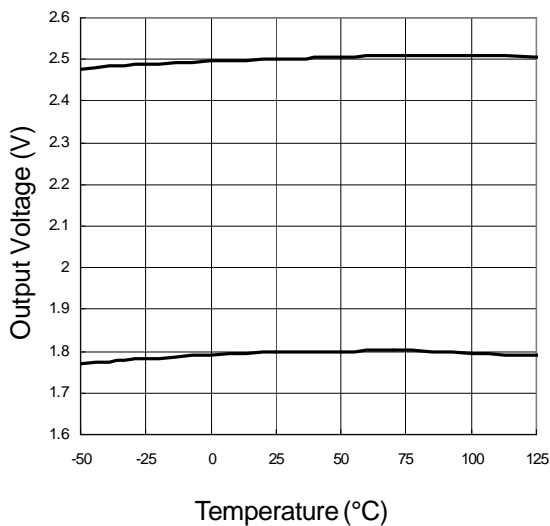

Output Voltage vs. Temperature

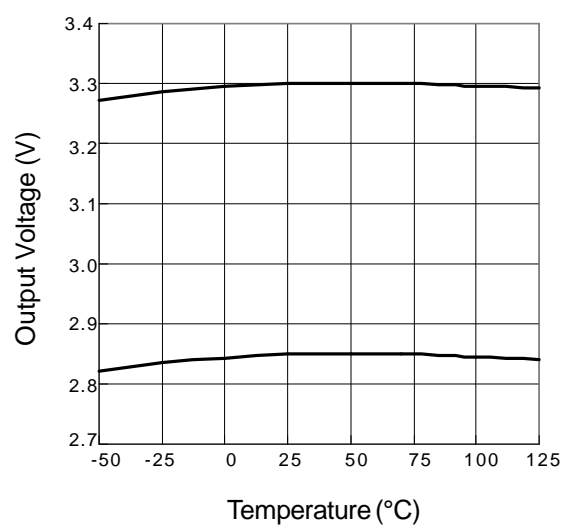

## Typical Characteristics (Cont.)

Adjustable Pin Current vs. Temperature

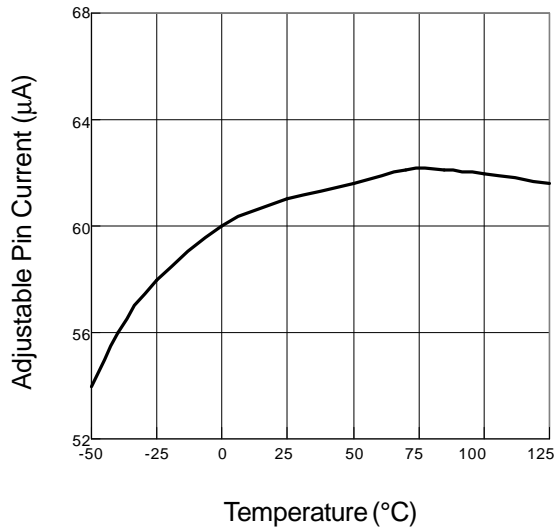

Input Current vs. Temperature

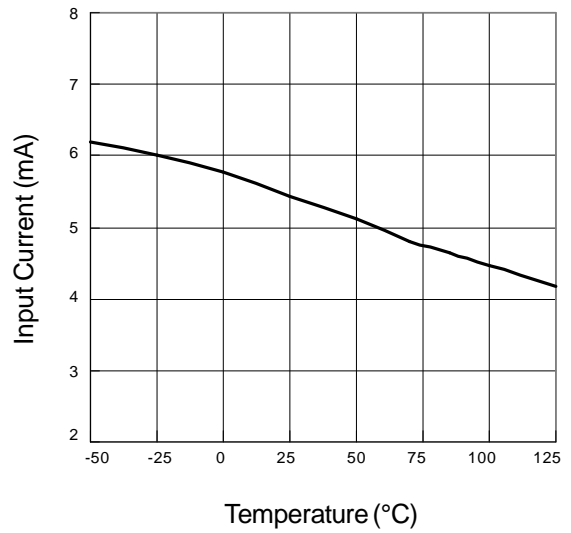

Current Limit vs. Temperature

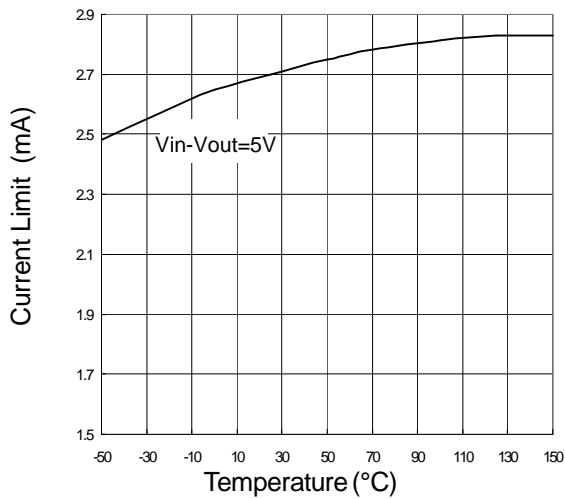

## Package Information

SOT-223 (Reference JEDEC Registration SOT-223)

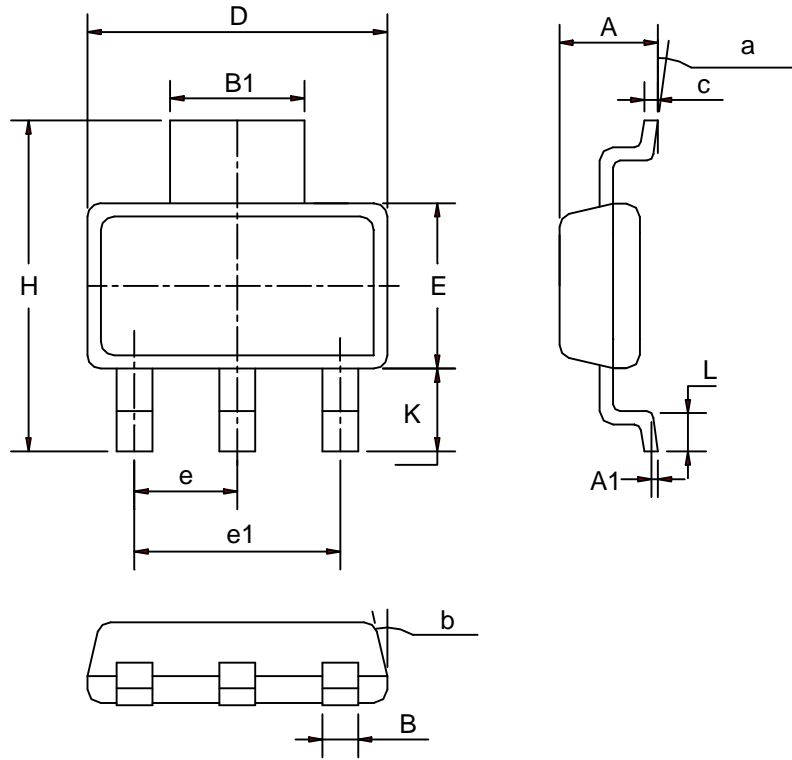

Dim	Millimeters		Inches	
	Min.	Max.	Min.	Max.
A	1.50	1.80	0.059	0.070
A1	0.02	0.08	0.001	0.003
B	0.60	0.80	0.023	0.031
B1	2.90	3.10	0.113	0.121
c	0.28	0.32	0.011	0.012
D	6.30	6.70	0.246	0.261
E	3.30	3.70	0.129	0.144
e	2.3 BSC		0.090 BSC	
E1	4.6 BSC		0.179 BSC	
H	6.70	7.30	0.261	0.285
L	0.91	1.10	0.035	0.043
K	1.50	2.00	0.059	0.078
$\alpha$	0°	10°	0°	10°
$\beta$	13°		°13	



Package Informaion

TO-252 (Reference JEDEC Registration TO-252)

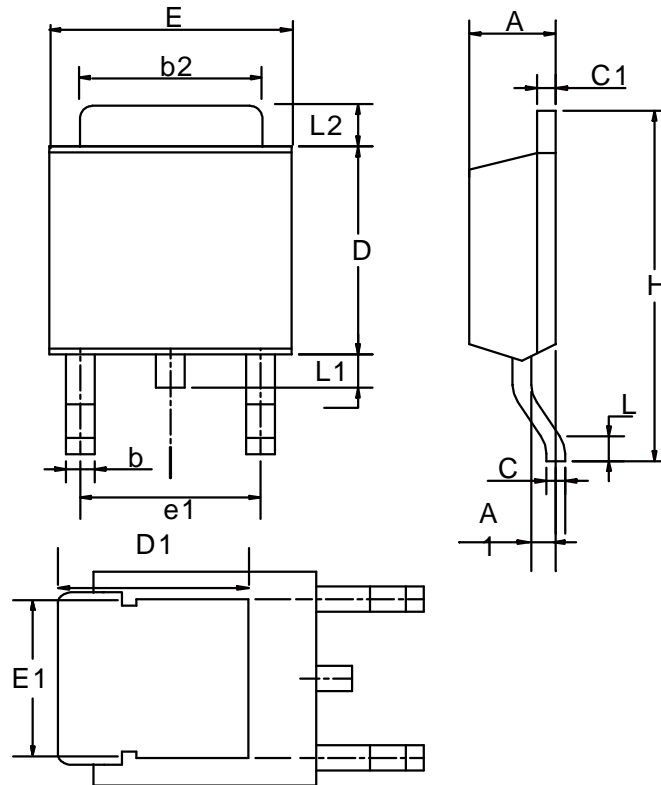

Dim	Millimeters		Inches	
	Min.	Max.	Min.	Max.
A	2.18	2.39	0.086	0.094
A1	0.89	1.27	0.035	0.050
b	0.508	0.89	0.020	0.035
b2	5.207	5.461	0.205	0.215
C	0.46	0.58	0.018	0.023
C1	0.46	0.58	0.018	0.023
D	5.334	6.22	0.210	0.245
D1	5.2 REF		0.205 REF	
E	6.35	6.73	0.250	0.265
E1	5.3 REF		0.209 REF	
e1	3.96	5.18	0.156	0.204
H	9.398	10.41	0.370	0.410
L	0.51		0.020	
L1	0.64	1.02	0.025	0.040
L2	0.89	2.032	0.035	0.080

Package Informaion

TO-220 (Reference JEDEC Registration TO-220)

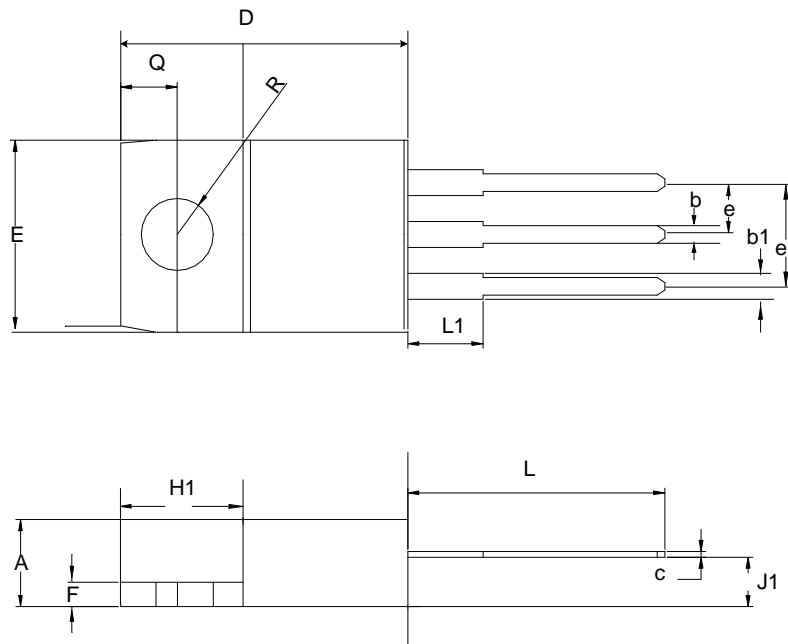

Dim	Millimeters		Inches	
	Min.	Max.	Min.	Max.
A	3.56	4.83	0.140	0.190
b1	1.14	1.78	0.045	0.070
b	0.51	1.14	0.020	0.045
c	0.31	1.14	0.012	0.045
D	14.23	16.51	0.560	0.650
e	2.29	2.79	0.090	0.110
e1	4.83	5.33	0.190	0.210
E	9.65	10.67	0.380	0.420
F	0.51	1.40	0.020	0.055
H1	5.84	6.86	0.230	0.270
J1	2.03	2.92	0.080	0.115
L	12.7	14.73	0.500	0.580
L1	3.65	6.35	0.143	0.250
R	3.53	4.09	0.139	0.161
Q	2.54	3.43	0.100	0.135

Package Informaion

TO-263 (Reference JEDEC Registration TO-263)

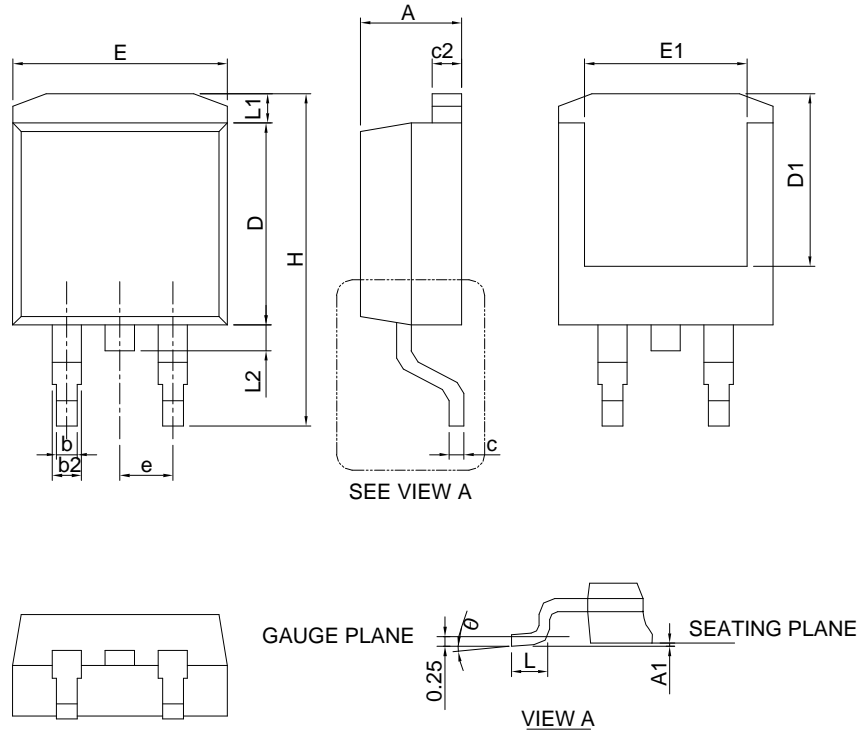

SYMBOL	TO-263-3			
	MILLIMETERS		INCHES	
	MIN.	MAX.	MIN.	MAX.
A	4.06	4.83	0.160	0.190
A1	0.00	0.25	0.000	0.010
b	0.51	0.99	0.020	0.039
b2	1.14	1.78	0.045	0.070
c	0.38	0.74	0.015	0.029
c2	1.14	1.65	0.045	0.065
D	8.38	9.65	0.330	0.380
D1	6.86	-	0.270	-
E	9.65	11.43	0.380	0.450
E1	6.22	-	0.245	-
e	2.54 BSC		0.100 BSC	
H	14.61	15.88	0.575	0.625
L	1.78	2.79	0.070	0.110
L1	-	1.68	-	0.066
L2	-	1.78	-	0.070
θ	0°	8°	0°	8°

### Carrier Tape & Reel Dimensions

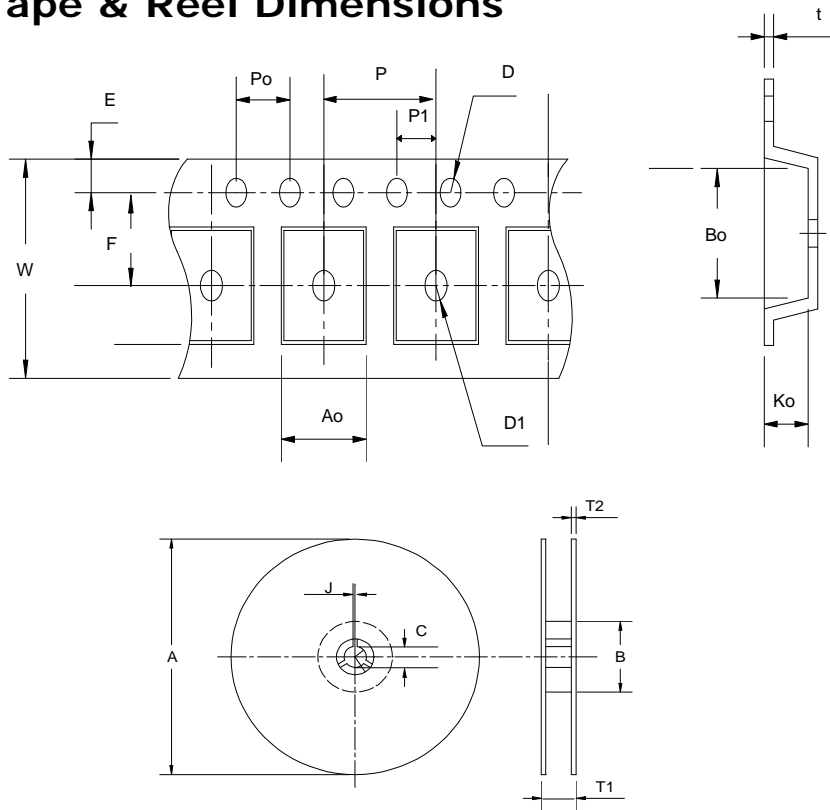

Application	A	B	C	J	T1	T2	W	P	E
TO-252	330 ±3	100 ± 2	13 ± 0.5	2 ± 0.5	16.4 +0.3 -0.2	2.5 ± 0.5	16 + 0.3 -0.1	8 ± 0.1	1.75 ± 0.1
	F	D	D1	Po	P1	Ao	Bo	Ko	t
	7.5 ± 0.1	1.5 + 0.1	1.5 ± 0.25	4.0 ± 0.1	2.0 ± 0.1	6.8 ± 0.1	10.4 ± 0.1	2.5 ± 0.1	0.3 ± 0.05
Application	A	B	C	J	T1	T2	W	P	E
TO-263	380 ±3	80 ± 2	13 ± 0.5	2 ± 0.5	24 ± 4	2 ± 0.3	24 + 0.3 -0.1	16 ± 0.1	1.75 ± 0.1
	F	D	D1	Po	P1	Ao	Bo	Ko	t
	11.5 ± 0.1	1.5 + 0.1	1.5 ± 0.25	4.0 ± 0.1	2.0 ± 0.1	10.8 ± 0.1	16.1 ± 0.1	5.2 ± 0.1	0.35 ± 0.01 3
Application	A	B	C	J	T1	T2	W	P	E
SOT-223	330 ±1	62 ± 1.5	12.75 ± 0.15	2 ± 0.6	12.4 ± 0.2	2 ± 0.2	12 ± 0.3	8 ± 0.1	1.75 ± 0.1
	F	D	D1	Po	P1	Ao	Bo	Ko	t
	5.5 ± 0.05	1.5 + 0.1	1.5 + 0.1	4.0 ± 0.1	2.0 ± 0.05	6.9 ± 0.1	7.5 ± 0.1	2.1 ± 0.1	0.3 ± 0.05

(mm)

### Cover Tape Dimensions

Application	Carrier Width	Cover Tape Width	Devices Per Reel
TO- 252	16	13.3	2500
TO- 263	24	21.3	1000
SOT- 223	12	9.3	2500

### Physical Specifications

Terminal Material	Solder-Plated Copper (Solder Material : 90/10 or 63/37 SnPb), 100%Sn
Lead Solderability	Meets EIA Specification RSI86-91, ANSI/J-STD-002 Category 3.

### Reflow Condition (IR/Convection or VPR Reflow)

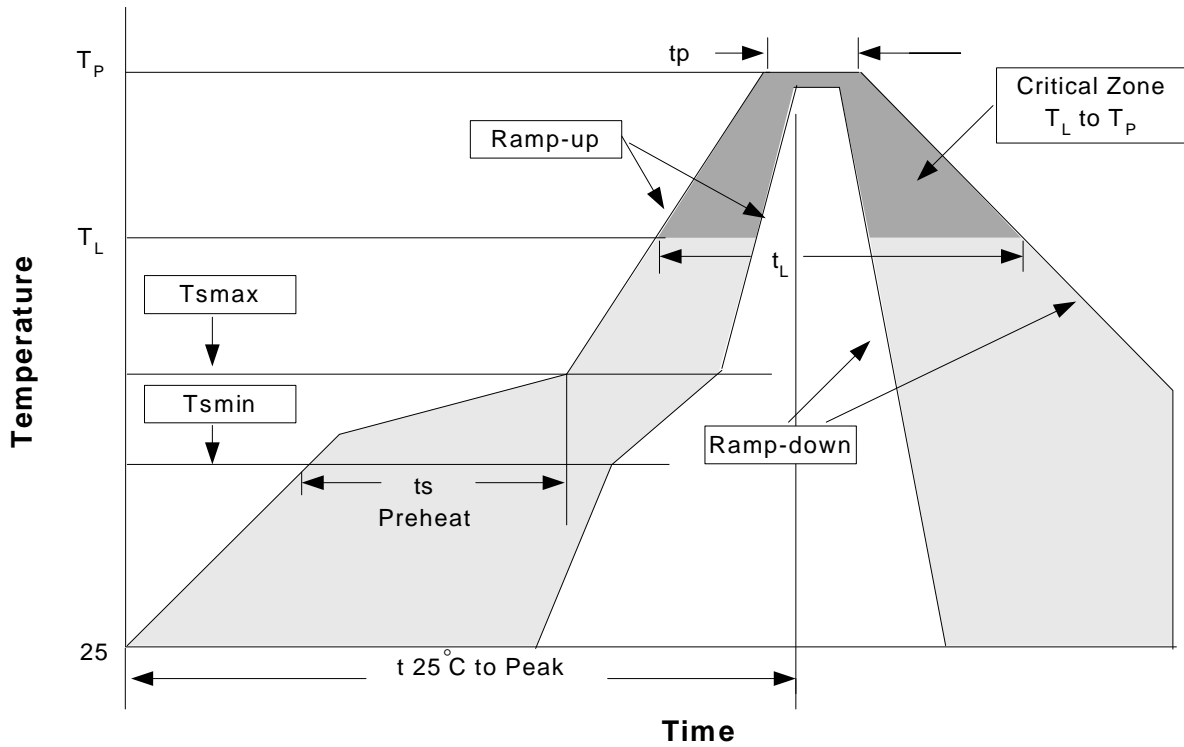

### Classification Reflow Profiles

Profile Feature	Sn-Pb Eutectic Assembly	Pb-Free Assembly
Average ramp-up rate (T <sub>L</sub> to T <sub>P</sub> )	3°C/second max.	3°C/second max.
Preheat		
- Temperature Min (T <sub>smin</sub> )	100°C	150°C
- Temperature Max (T <sub>smax</sub> )	150°C	200°C
- Time (min to max) (t <sub>s</sub> )	60-120 seconds	60-180 seconds
Time maintained above:		
- Temperature (T <sub>L</sub> )	183°C	217°C
- Time (t <sub>L</sub> )	60-150 seconds	60-150 seconds
Peak/Classification Temperature (T <sub>P</sub> )	See table 1	See table 2
Time within 5°C of actual Peak Temperature (t <sub>p</sub> )	10-30 seconds	20-40 seconds
Ramp-down Rate	6°C/second max.	6°C/second max.
Time 25°C to Peak Temperature	6 minutes max.	8 minutes max.

Notes: All temperatures refer to topside of the package. Measured on the body surface.

## Classification Reflow Profiles (Cont.)

Table 1. SnPb Eutectic Process – Package Peak Reflow Temperatures

Package Thickness	Volume mm <sup>3</sup> <350	Volume mm <sup>3</sup> ≥350
<2.5 mm	240 +0/-5°C	225 +0/-5°C
≥2.5 mm	225 +0/-5°C	225 +0/-5°C

Table 2. Pb-free Process – Package Classification Reflow Temperatures

Package Thickness	Volume mm <sup>3</sup> <350	Volume mm <sup>3</sup> 350-2000	Volume mm <sup>3</sup> >2000
<1.6 mm	260 +0°C*	260 +0°C*	260 +0°C*
1.6 mm – 2.5 mm	260 +0°C*	250 +0°C*	245 +0°C*
≥2.5 mm	250 +0°C*	245 +0°C*	245 +0°C*

\*Tolerance: The device manufacturer/supplier **shall** assure process compatibility up to and including the stated classification temperature (this means Peak reflow temperature +0°C. For example 260°C+0°C) at the rated MSL level.

## Reliability Test Program

Test item	Method	Description
SOLDERABILITY	MIL-STD-883D-2003	245°C, 5 sec
HOLT	MIL-STD-883D-1005.7	1000 Hrs Bias @125°C
PCT	JESD-22-B,A102	168 Hrs, 100%RH, 121°C
TST	MIL-STD-883D-1011.9	-65°C~150°C, 200 Cycles
ESD	MIL-STD-883D-3015.7	VHBM > 2KV, VMM > 200V
Latch-Up	JESD 78	10ms, 1 <sub>tr</sub> > 100mA

## Customer Service

### Anpec Electronics Corp.

Head Office :

No.6, Dusing 1st Road, SBIP,

Hsin-Chu, Taiwan, R.O.C.

Tel : 886-3-5642000

Fax : 886-3-5642050

Taipei Branch :

2F, No. 11, Lane 218, Sec 2 Jhongsing Rd.,

Sindian City, Taipei County 23146, Taiwan, R. O. C.

Tel : 886-2-2910-3838

Fax : 886-2-2917-3838