

Customer Information Sheet

DRAWING No.: M20-786XXXXR

IF IN DOUBT - ASK

(C)

NOT TO SCALE

THIRD ANGLE PROJECTION

ALL DIMENSIONS IN mm

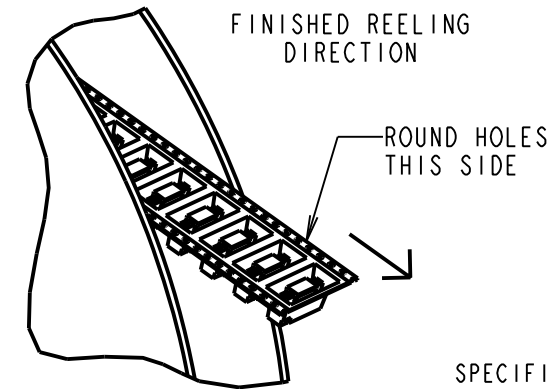
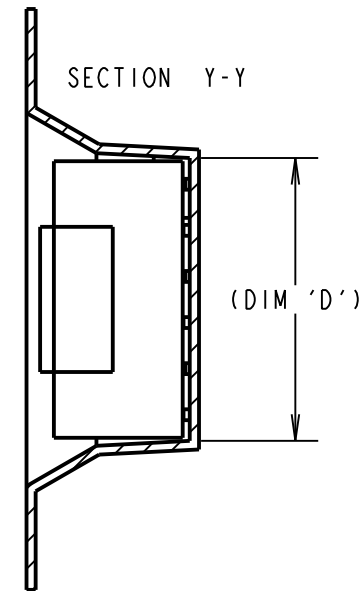
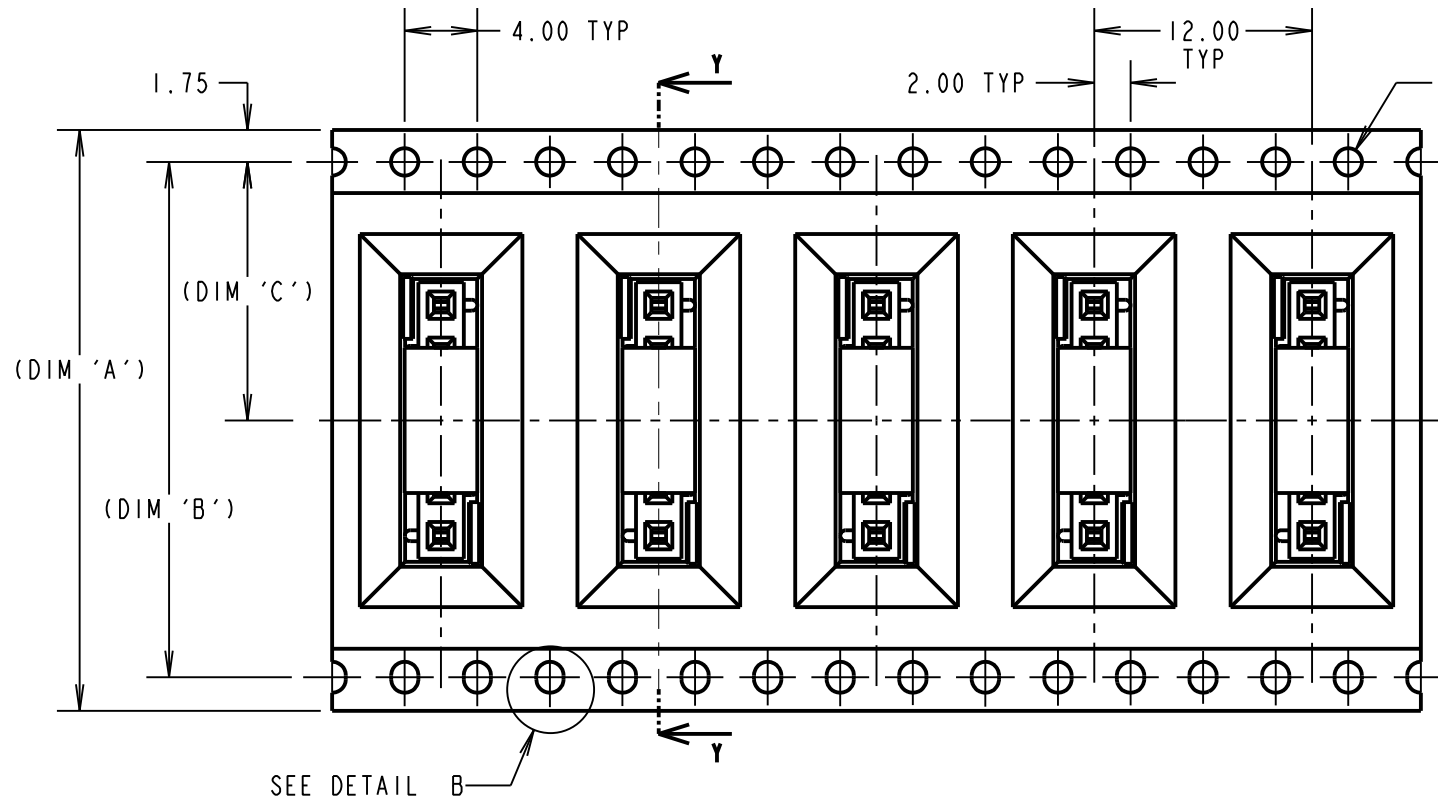

ORDER CODE:
M20-786XXXXR

No. OF CONTACTS: _____
02 TO 40

FINISH: _____
42 - SELECTIVE GOLD + 100% TIN
46 - 100% TIN

SPECIFICATION:

MATERIAL:
MOULDING = NYLON 6T UL94V-0, BLACK
CONTACTS = PHOSPHOR BRONZE

FINISH (OVER NICKEL):
42 = GOLD ON CONTACT AREA, 100% TIN ON TAILS
46 = 100% TIN

ELECTRICAL:
CURRENT RATING = 3A
VOLTAGE PROOF = 600V AC FOR 1 MINUTE
CONTACT RESISTANCE = 20mΩ MAX
INSULATION RESISTANCE = 1000MΩ MIN

MECHANICAL:
DURABILITY = 300 CYCLES MIN
INSERTION FORCE = 2.0N MAX
WITHDRAWAL FORCE = 0.3N MIN

ENVIRONMENTAL:
TEMPERATURE RANGE = -40°C TO +105°C

PACKING:
TAPE & REEL

No OF CONTACTS	COPLANARITY TOLERANCE
1x02 TO 1x10	0.12mm MAX
1x11 TO 1x15	0.15mm MAX
1x16 TO 1x20	0.15mm MAX
1x21 TO 1x25	0.20mm MAX
1x26 TO 1x30	0.25mm MAX
1x31 TO 1x35	0.30mm MAX
1x36 TO 1x40	0.35mm MAX

PART No.	DIM 'A'	DIM 'B'	DIM 'C'	DIM 'D'	QTY/REEL
M20-78606XXR	32.00±0.30	28.40	14.20±0.15	15.80	400
M20-78611XXR	44.00±0.30	40.40	20.20±0.15	28.30	550
M20-78616XXR	56.00±0.30	52.40	26.20±0.15	41.40	550
M20-78620XXR	72.00±0.30	68.40±0.15	34.20±0.15	51.40	550

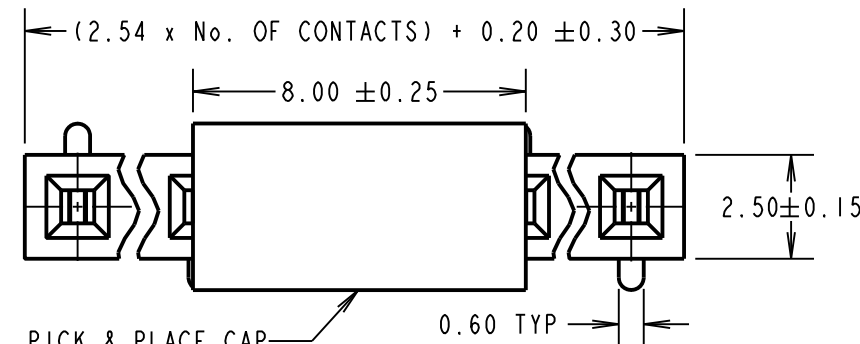

NOTES:
1. CO-PLANARITY: FLATNESS OF SMT TAILS MUST NOT EXCEED VALUES GIVEN IN TABLE.

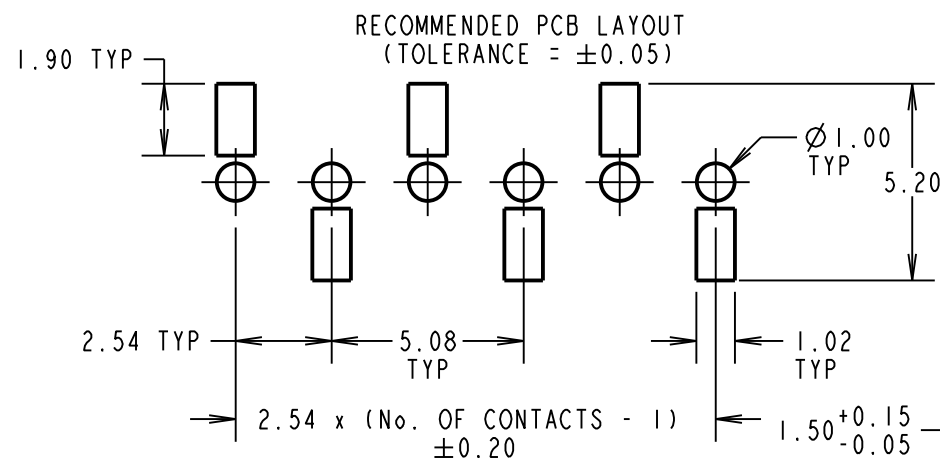

PART SECTION X-X

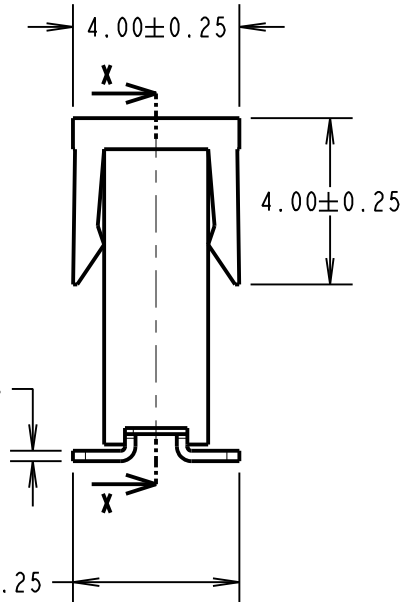
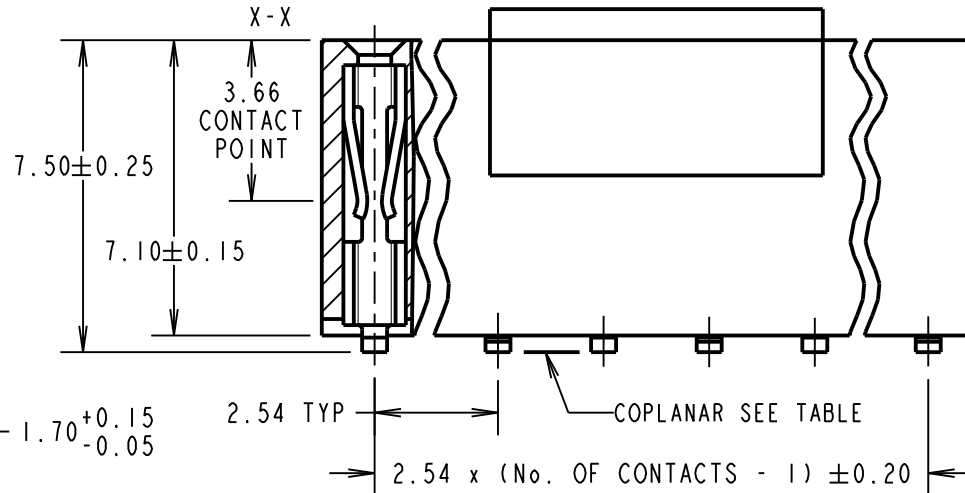

REEL DETAILS

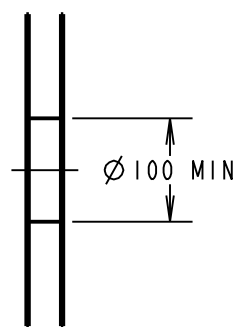

DETAIL B SCALE 5

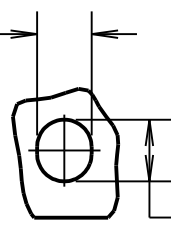

MSP	6	12.12.16	13421
NAME	ISS.	DATE	C/NOTE
APPROVED: M. PERREN			
CHECKED: S. BENNETT			
DRAWN: S. MCCULLAGH			
CUSTOMER REF.:			
ASSEMBLY DRG:			

HARWIN

www.harwin.com
technical@harwin.com

THIS DRAWING AND ANY INFORMATION OR DESCRIPTIVE MATTER SET OUT HEREON ARE CONFIDENTIAL AND COPYRIGHT PROPERTY OF THE HARWIN GROUP AND MUST NOT BE DISCLOSED, LOANED, COPIED OR USED FOR MANUFACTURING, TENDERING OR FOR ANY OTHER PURPOSE WITHOUT THEIR WRITTEN PERMISSION.

TOLERANCES
X. = ±1mm
X.X = ±0.25mm
X.XX = ±0.10mm
X.XXX = ±0.01mm
ANGLES = ±5°
UNLESS STATED

MATERIAL:
SEE ABOVE
FINISH: SEE ABOVE
S/AREA: mm²

TITLE: 2.54mm PITCH SIL VERTICAL FEMALE SMT SKT ASSY DUAL ENTRY - TAPE & REEL

DRAWING NUMBER: **M20-786XXXXR** SHT 2 OF 2