

# GF1A THRU GF1M

## SURFACE MOUNT GLASS PASSIVATED JUNCTION RECTIFIER

Reverse Voltage - 50 to 1000 Volts      Forward Current - 1.0 Ampere

**PATENTED\***

DO-214BA

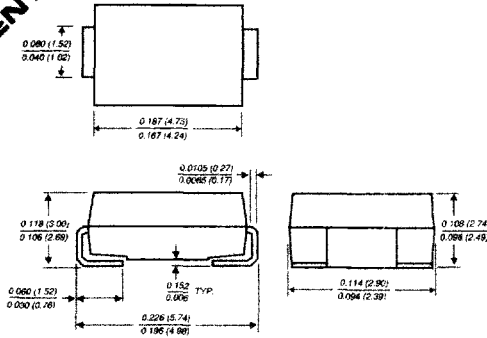

Dimensions in inches and (millimeters)

\* Glass-plastic encapsulation technique is covered by Patent No. 3,996,602, brazed-lead assembly by Patent No. 3,930,306 and lead forming by Patent No. 5,151,846

**SUPERRECTIFIER®**

### FEATURES

- ◆ Plastic package has Underwriters Laboratory Flammability Classification 94V-0
- ◆ Ideal for surface mount automotive applications
- ◆ High temperature metallurgically bonded construction
- ◆ Glass passivated cavity-free junction
- ◆ Capable of meeting environmental standards of MIL-S-19500
- ◆ Built-in strain relief
- ◆ Easy pick and place
- ◆ High temperature soldering guaranteed: 450°C/5 seconds at terminals
- ◆ Complete device submersible temperature of 265°C for 10 seconds in solder bath

### MECHANICAL DATA

**Case:** JEDEC DO-214BA molded plastic over glass body

**Terminals:** Solder plated, solderable per MIL-STD-750, Method 2026

**Polarity:** Color band denotes cathode end

**Mounting Position:** Any

**Weight:** 0.0048 ounces, 0.120 gram

### MAXIMUM RATINGS AND ELECTRICAL CHARACTERISTICS

Ratings at 25°C ambient temperature unless otherwise specified.

	SYMBOLS	GF1A	GF1B	GF1D	GF1G	GF1J	GF1K	GF1M	UNITS	
Device marking code		GA	GB	GD	GG	GJ	GK	GM		
Maximum repetitive peak reverse voltage	V <sub>RRM</sub>	50	100	200	400	600	800	1000	Volts	
Maximum RMS voltage	V <sub>RMS</sub>	35	70	140	280	420	560	700	Volts	
Maximum DC blocking voltage	V <sub>DC</sub>	50	100	200	400	600	800	1000	Volts	
Maximum average forward rectified current at T <sub>L</sub> =125°C	I <sub>(AV)</sub>	1.0							Amp	
Peak forward surge current 8.3ms single half sine-wave superimposed on rated load (JEDEC Method)	I <sub>FSM</sub>	30.0							Amps	
Maximum instantaneous forward voltage at 1.0A	V <sub>F</sub>					1.10	1.20		Volts	
Maximum DC reverse current at rated DC blocking voltage	I <sub>R</sub>					5.0	50.0			μA
Typical reverse recovery time (NOTE 1)	t <sub>rr</sub>					2.0				μs
Typical junction capacitance (NOTE 2)	C <sub>J</sub>					15.0				pF
Typical thermal resistance (NOTE 3)	R <sub>θJA</sub> R <sub>θJL</sub>					80.0	26.0			°C/W
Operating junction and storage temperature range	T <sub>J</sub> , T <sub>STG</sub>	-65 to +175							°C	

**NOTES:**

- (1) Reverse recovery test conditions: I<sub>F</sub>=0.5A, I<sub>R</sub>=1.0A, I<sub>r</sub>=0.25A
- (2) Measured at 1.0 MHz and applied V<sub>R</sub>=4.0 Volts
- (3) Thermal resistance from junction to ambient and from junction to lead P.C.B. mounted on 0.2 x 0.2" (5.0 x 5.0mm) copper pad areas

# RATINGS AND CHARACTERISTIC CURVES GF1A THRU GF1M

FIG. 1 - FORWARD CURRENT DERATING CURVE

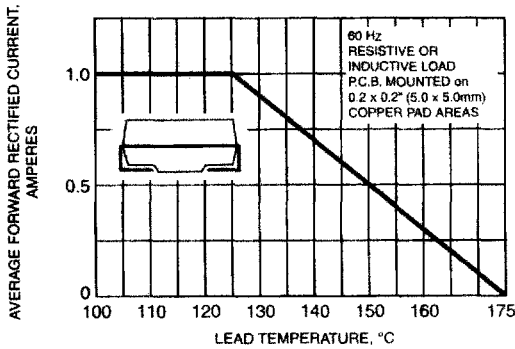

FIG. 2 - MAXIMUM NON-REPETITIVE PEAK FORWARD SURGE CURRENT

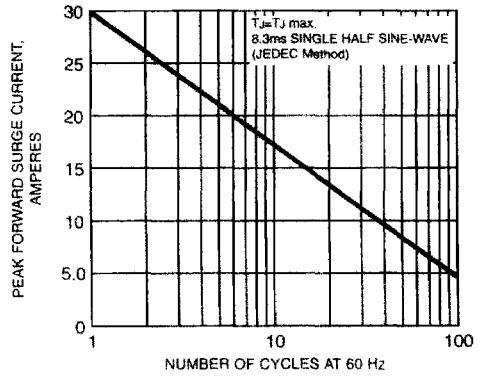

FIG. 3 - TYPICAL INSTANTANEOUS FORWARD CHARACTERISTICS

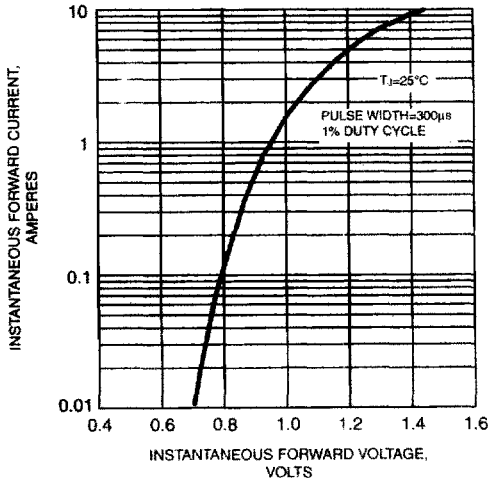

FIG. 4 - TYPICAL REVERSE CHARACTERISTICS

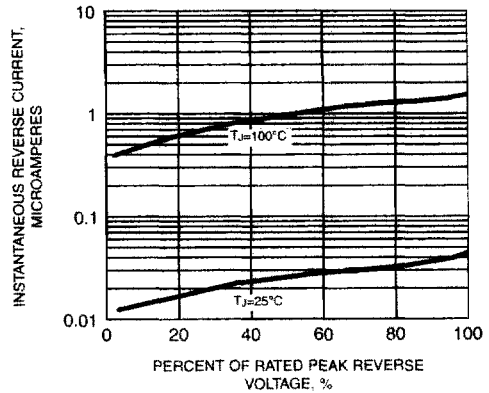

FIG. 5 - TYPICAL JUNCTION CAPACITANCE

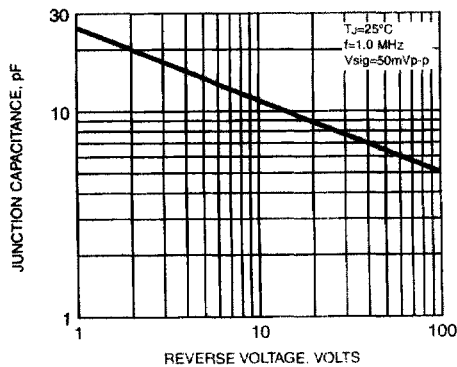

FIG. 6 - TYPICAL TRANSIENT THERMAL IMPEDANCE

