

74160, 74161, 74163, LS160A, LS161A, LS162A, LS163A Counters

Logic Products

'160, '162 BCD Decade Counter
'161, '163 4-Bit Binary Counter
Product Specification

FEATURES

- Synchronous counting and loading
- Two Count Enable inputs for n-bit cascading
- Positive edge-triggered clock
- Asynchronous reset ('160, '161)
- Synchronous reset ('162, '163)
- Hysteresis on Clock input (LS only)

DESCRIPTION

Synchronous presettable decade (74160, 74LS160A, 74LS162A) and 4-bit (74161, 74LS161A, 74163, 74LS163A) counters feature an internal carry look-ahead and can be used for high-speed counting. Synchronous operation is provided by having all flip-flops clocked simultaneously on the positive-going edge of the clock. The Clock input is buffered.

The outputs of the counters may be preset to HIGH or LOW level. A LOW level at the Parallel Enable (\overline{PE}) input disables the counting action and causes the data at the $D_0 - D_3$ inputs to be loaded into the counter on the positive-going edge of the clock (providing that the set-up and hold requirements for \overline{PE} are met). Preset takes place regardless of the levels at Count Enable (CEP, CET) inputs.

PIN CONFIGURATION

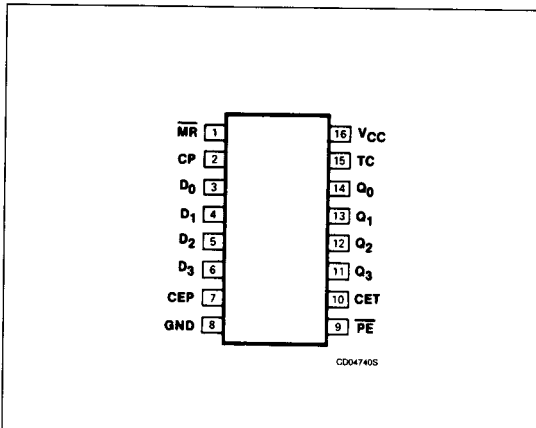

LOGIC SYMBOL

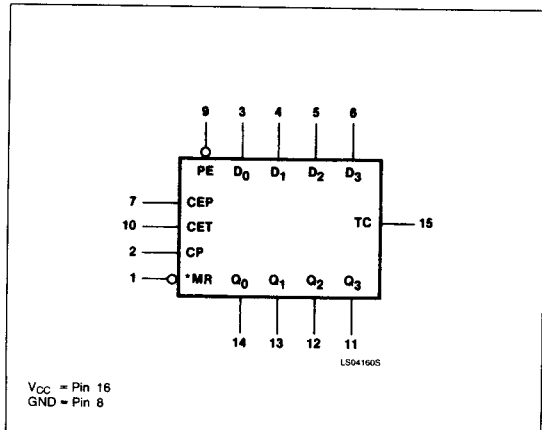

TYPE	TYPICAL PROPAGATION DELAY	TYPICAL SUPPLY CURRENT (TOTAL)
74160 - 74163	32MHz	61mA
74LS160A - 74LS163A	32MHz	19mA

ORDERING CODE

PACKAGES	COMMERCIAL RANGE $V_{CC} = 5V \pm 5\%$; $T_A = 0^\circ C$ to $+70^\circ C$
Plastic DIP	N74160N, N74LS160AN, N74161N, N74LS161AN N74LS162AN, N74163N, N74LS163AN
Plastic SO	N74LS161AD, N74S163AD

NOTE:

For information regarding devices processed to Military Specifications, see the Signetics Military Products Data Manual.

INPUT AND OUTPUT LOADING AND FAN-OUT TABLE

PINS	DESCRIPTION	74	74LS
CP, CET	Inputs	2uI	2LSuI
D, CEP	Inputs	1uI	1LSuI
\overline{PE}	Input	1uI	2LSuI
All	Outputs	10uI	10LSuI
\overline{MR}	Input ('160, '161)	1uI	1LSuI
\overline{MR}	Input ('162, '163)	1uI	2LSuI

NOTE:

Where a 74 unit load (uI) is understood to be $40\mu A$ I_{IH} and $-1.6mA$ I_{IL} , and a 74LS unit load (LSuI) is $20\mu A$ I_{IH} and $-0.4mA$ I_{IL} .

Counters

74160, 74161, 74163, LS160A, LS161A, LS162A, LS163A

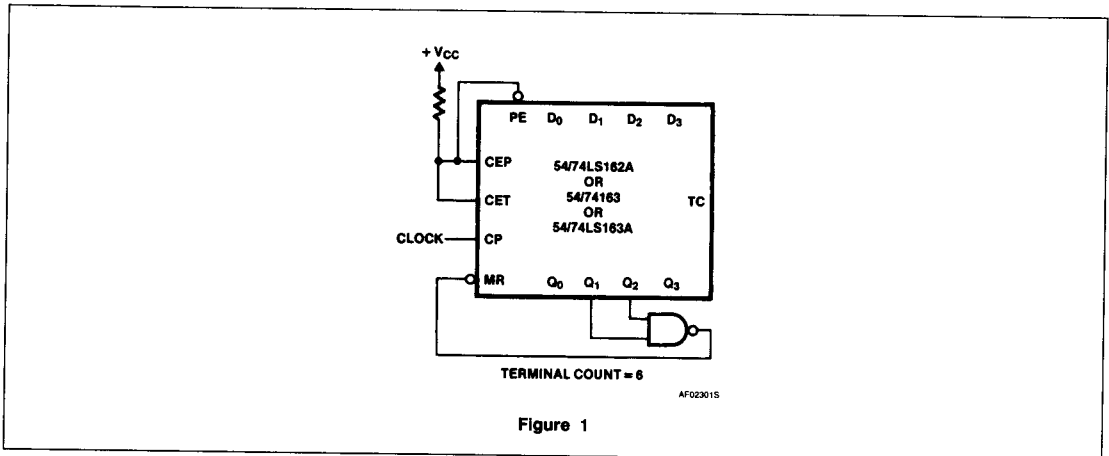

Figure 1

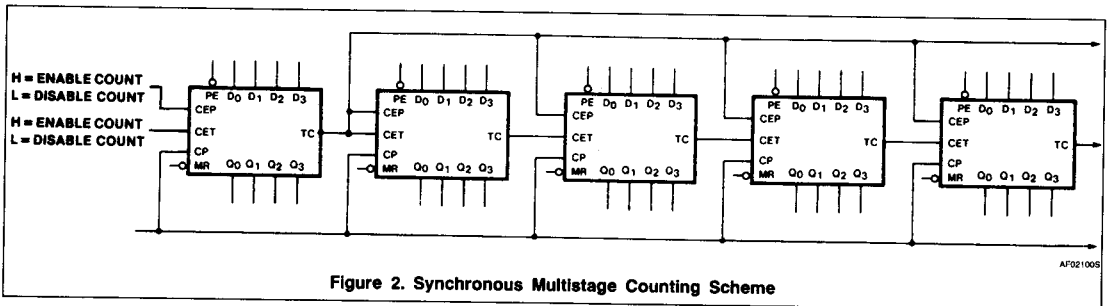
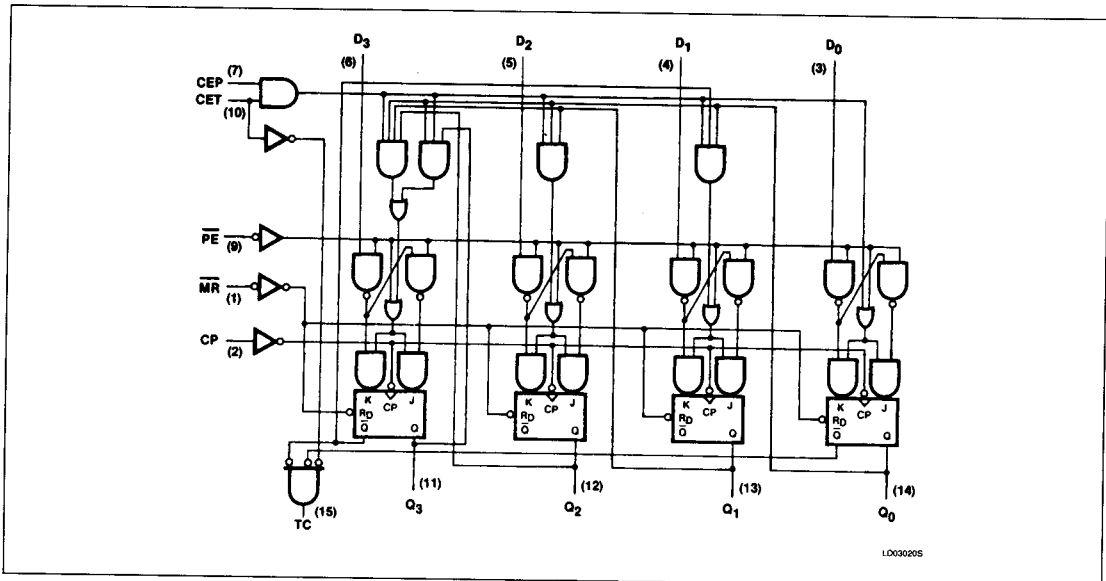

Figure 2. Synchronous Multistage Counting Scheme

LOGIC DIAGRAM, 74160



Counters

74160, 74161, 74163, LS160A, LS161A, LS162A, LS163A

LOGIC DIAGRAMS

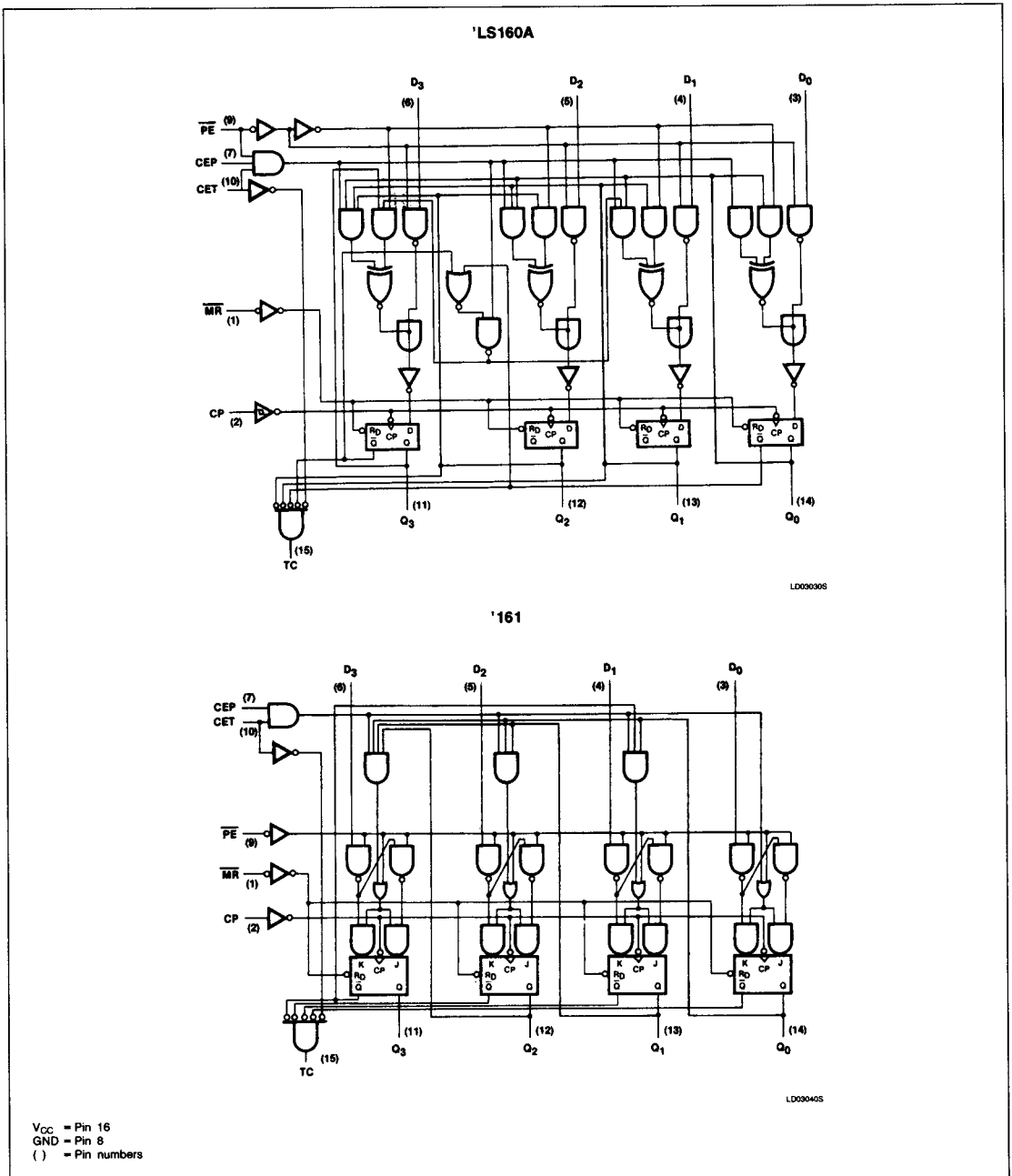

5

Counters

74160, 74161, 74163, LS160A, LS161A, LS162A, LS163A

LOGIC DIAGRAMS

'LS161A

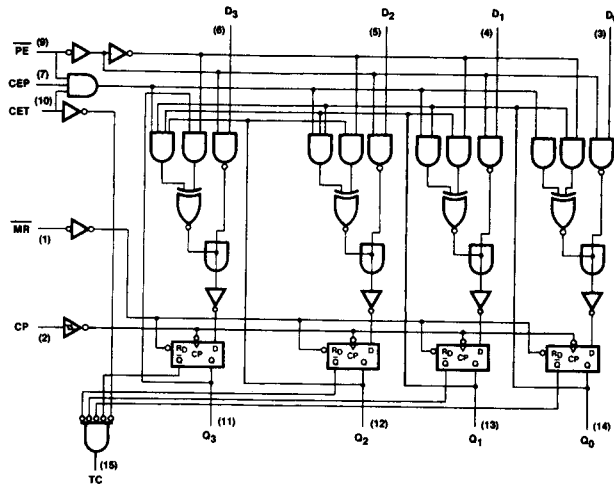

LD030505

'LS162A

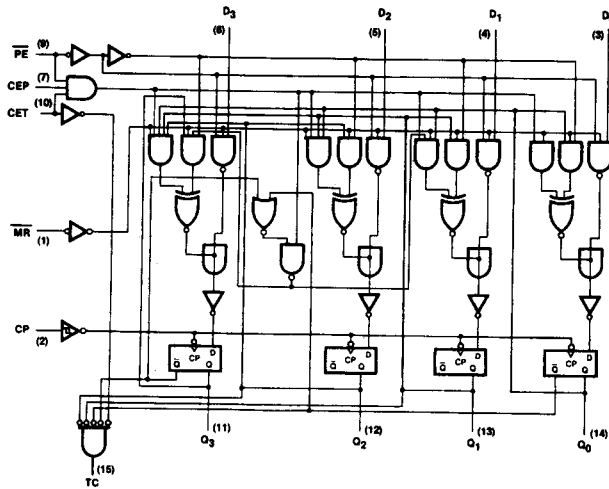

LD030605

V_{CC} = Pin 16
 GND = Pin 8
 () = Pin numbers

Counters

74160, 74161, 74163, LS160A, LS161A, LS162A, LS163A

LOGIC DIAGRAMS

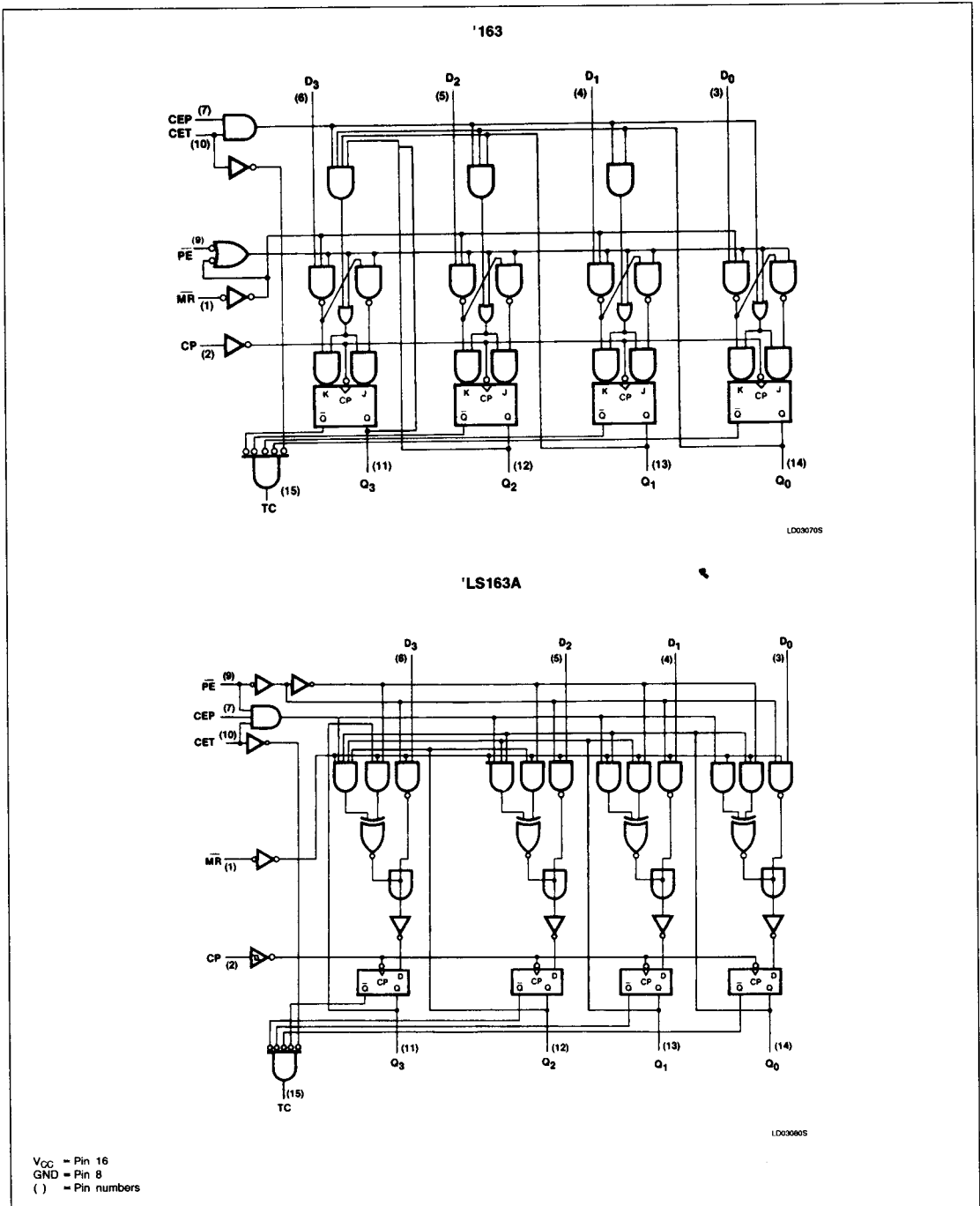

Counters

74160, 74161, 74163, LS160A, LS161A, LS162A, LS163A

MODE SELECT — FUNCTION TABLE, '160, '161

OPERATING MODE	INPUTS						OUTPUTS	
	\overline{MR}	CP	CEP	CET	\overline{PE}	D_n	Q_n	TC
Reset (clear)	L	X	X	X	X	X	L	L
Parallel load	H	\uparrow	X	X	l	l	L	L
	H	\uparrow	X	X	l	h	H	(a)
Count	H	\uparrow	h	h	$h^{(c)}$	X	count	(a)
Hold (do nothing)	H	X	$l^{(b)}$	X	$h^{(c)}$	X	q_n	(a)
	H	X	X	$l^{(b)}$	$h^{(c)}$	X	q_n	L

MODE SELECT — FUNCTION TABLE, '162, '163

OPERATING MODE	INPUTS						OUTPUTS	
	\overline{MR}	CP	CEP	CET	\overline{PE}	D_n	Q_n	TC
Reset (clear)	l	\uparrow	X	X	X	X	L	L
Parallel load	$h^{(f)}$	\uparrow	X	X	l	l	L	L
	$h^{(f)}$	\uparrow	X	X	l	h	H	(d)
Count	$h^{(f)}$	\uparrow	h	h	$h^{(f)}$	X	count	(d)
Hold (do nothing)	$h^{(f)}$	X	$l^{(e)}$	X	$h^{(f)}$	X	q_n	(d)
	$h^{(f)}$	X	X	$l^{(e)}$	$h^{(f)}$	X	q_n	L

H = HIGH voltage level steady state.

L = LOW voltage level steady state.

h = HIGH voltage level one set-up time prior to the LOW-to-HIGH clock transition.

l = LOW voltage level one set-up time prior to the LOW-to-HIGH clock transition.

X = Don't care.

 q = Lower case letters indicate the state of the referenced output prior to the LOW-to-HIGH clock transition. \uparrow = LOW-to-HIGH clock transition.

NOTES:

(a) The TC output is HIGH when CET is HIGH and the counter is at Terminal Count (HHHH for '161 and HLLH for '160).

(b) The HIGH-to-LOW transition of CEP or CET on the 74161 and 74160 should only occur while CP is HIGH for conventional operation.

(c) The LOW-to-HIGH transition of \overline{PE} on the 74161 and 74160 should only occur while CP is HIGH for conventional operation.

(d) The TC output is HIGH when CET is HIGH and the counter is at Terminal Count (HLLH for '162 and HHHH for '163).

(e) The HIGH-to-LOW transition of CEP or CET on the 74163 should only occur while CP is HIGH for conventional operation.

(f) The LOW-to-HIGH transition of \overline{PE} or \overline{MR} on the 74163 should only occur while CP is HIGH for conventional operation.

ABSOLUTE MAXIMUM RATINGS (Over operating free-air temperature range unless otherwise noted.)

PARAMETER		74	74LS	UNIT
V_{CC}	Supply voltage	7.0	7.0	V
V_{IN}	Input voltage	-0.5 to +5.5	-0.5 to +7.0	V
I_{IN}	Input current	-30 to +5	-30 to +1	mA
V_{OUT}	Voltage applied to output in HIGH output state	-0.5 to + V_{CC}	-0.5 to + V_{CC}	V
T_A	Operating free-air temperature range	0 to 70		°C

Counters

74160, 74161, 74163, LS160A, LS161A, LS162A, LS163A

RECOMMENDED OPERATING CONDITIONS

PARAMETER	74			74LS			UNIT
	Min	Nom	Max	Min	Nom	Max	
V _{CC} Supply voltage	4.75	5.0	5.25	4.75	5.0	5.25	V
V _{IH} HIGH-level input voltage	2.0			2.0			V
V _{IL} LOW-level input voltage			+0.8			+0.8	V
I _{IK} Input clamp current			-12			-18	mA
I _{OH} HIGH-level output current			-800			-400	μA
I _{OL} LOW-level output current			16			8	mA
T _A Operating free-air temperature	0		70	0		70	°C

TEST CIRCUITS AND WAVEFORMS

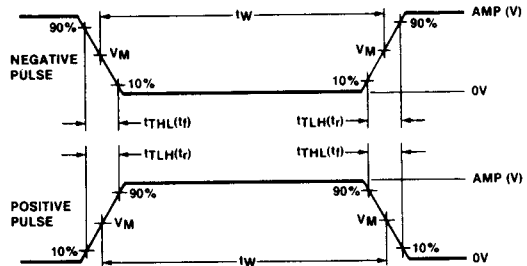
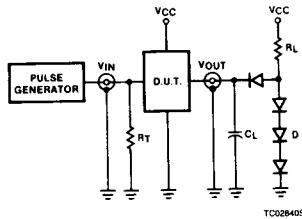

V_M = 1.3V for 74LS; V_M = 1.5V for all other TTL families.

Test Circuit For 74 Totem-Pole Outputs

DEFINITIONS

R_L = Load resistor to V_{CC}; see AC CHARACTERISTICS for value.

C_L = Load capacitance includes jig and probe capacitance; see AC CHARACTERISTICS for value.

R_T = Termination resistance should be equal to Z_{OUT} of Pulse Generators.

D = Diodes are 1N916, 1N3064, or equivalent.

t_{TLH}, t_{THL} Values should be less than or equal to the table entries.

Input Pulse Definition

FAMILY	INPUT PULSE REQUIREMENTS				
	Amplitude	Rep. Rate	Pulse Width	t _{TLH}	t _{THL}
74	3.0V	1MHz	500ns	7ns	7ns
74LS	3.0V	1MHz	500ns	15ns	6ns
74S	3.0V	1MHz	500ns	2.5ns	2.5ns

Counters

74160, 74161, 74163, LS160A, LS161A, LS162A, LS163A

DC ELECTRICAL CHARACTERISTICS (Over recommended operating free-air temperature range unless otherwise noted.)

PARAMETER	TEST CONDITIONS ¹		74160, '161 '163			74LS160A, '161A '162A, '163A			UNIT
			Min	Typ ²	Max	Min	Typ ²	Max	
V _{OH} HIGH-level output voltage	V _{CC} = MIN, V _{IH} = MIN, V _{IL} = MAX, I _{OH} = MAX		2.4	3.4		2.7	3.4		V
V _{OL} LOW-level output voltage	V _{CC} = MIN, V _{IL} = MAX, V _{IH} = MIN	I _{OL} = MAX		0.2	0.4		0.35	0.5	V
		I _{OL} = 4mA (74LS)					0.25	0.4	V
V _{IK} Input clamp voltage	V _{CC} = MIN, I _I = I _{IK}				-1.5			-1.5	V
I _I Input current at maximum input voltage	V _{CC} = MAX	V _I = 5.5V			1.0				mA
		V _I = 7.0V	D, CEP					0.1	mA
			PE, CP, CET					0.2	mA
			MR ('LS160A, 'LS161A)					0.1	mA
			MR ('LS162A, 'LS163A)					0.2	mA
I _{IH} HIGH-level input current	V _{CC} = MAX	V _I = 2.4V	CP, CET		80				μA
			Other inputs		40				μA
		V _I = 2.7V	D, CEP					20	μA
			PE, CP, CET					40	μA
			MR ('LS160A, 'LS161A)					20	μA
			MR ('LS162A, 'LS163A)					40	μA
I _{IL} LOW-level input current	V _{CC} = MAX	V _I = 0.4V	CP, CET		-3.2				mA
			Other inputs		-1.6				mA
		V _I = 0.4V	D, CEP					-0.4	mA
			PE, CP, CET					-0.8	mA
			MR ('LS160A, 'LS161A)					-0.4	mA
			MR ('LS162A, 'LS163)					-0.8	mA
I _{OS} Short-circuit output current ³	V _{CC} = MAX		-18		-57	-20		-100	mA
I _{CC} Supply current ⁴ (total)	V _{CC} = MAX	I _{CC} H All outputs HIGH		59	94		18	31	mA
		I _{CC} L All outputs LOW		63	101		19	32	mA

NOTES:

- For conditions shown as MIN or MAX, use the appropriate value specified under recommended operating conditions for the applicable type.
- All typical values are at V_{CC} = 5V, T_A = 25°C.
- I_{OS} is tested with V_{OUT} = +0.5V and V_{CC} = V_{CC} MAX + 0.5V. Not more than one output should be shorted at a time and duration of the short circuit should not exceed one second.
- I_{CC}H is measured with PE input HIGH, again with PE input LOW, all other inputs HIGH and outputs open. I_{CC}L is measured with Clock input HIGH, again with Clock input LOW, all other inputs low and outputs open.

Counters

74160, 74161, 74163, LS160A, LS161A, LS162A, LS163A

AC ELECTRICAL CHARACTERISTICS $T_A = 25^\circ\text{C}$, $V_{CC} = 5.0\text{V}$

PARAMETER	TEST CONDITIONS	74		74LS		UNIT
		$C_L = 15\text{pF}$, $R_L = 400\Omega$		$C_L = 15\text{pF}$, $R_L = 2\text{k}\Omega$		
		Min	Max	Min	Max	
f_{MAX} Maximum clock frequency	Waveform 1	25		25		MHz
t_{PLH} Propagation delay t_{PHL} Clock to terminal count	Waveform 1		35		35	ns
t_{PLH} Propagation delay t_{PHL} Clock to Q outputs	Waveform 1, PE = HIGH		20 23		24 27	ns
t_{PLH} Propagation delay t_{PHL} Clock to Q outputs	Waveform 1, PE = LOW		25 29		24 27	ns
t_{PLH} Propagation delay t_{PHL} CET input to TC output	Waveform 2		16 16		14 14	ns
t_{PHL} Propagation delay, \overline{MR} to Q outputs ('160, '161)	Waveform 3		38		28	ns

NOTE:

Per industry convention, f_{MAX} is the worst case value of the maximum device operating frequency with no constraints on t_r , t_f , pulse width or duty cycle.

AC SET-UP REQUIREMENTS $T_A = 25^\circ\text{C}$, $V_{CC} = 5.0\text{V}$

PARAMETER	TEST CONDITIONS	74		74LS		UNIT
		Min	Max	Min	Max	
$t_{W(L)}$ Clock pulse width (LOW)	Waveform 1	25		25		ns
t_W Master Reset pulse width ('160, '161)	Waveform 3	20		20		ns
t_W Master Reset pulse width ('162, '163)	Waveform 6	20		20		ns
t_s Set-up time, data to clock	Waveform 5	20		20		ns
t_h Hold time, data to clock ¹	Waveform 5	3		3		ns
t_s Set-up time, CEP or CET to clock	Waveform 4	20		20		ns
t_h Hold time, CEP or CET to clock	Waveform 4	0		0		ns
t_s Set-up time, \overline{PE} to clock	Waveform 5	25		20		ns
t_h Hold time, \overline{PE} to clock	Waveform 5	0		0		ns
t_s Set-up time, \overline{MR} to clock ('162, '163)	Waveform 6	20		20		ns
t_h Hold time, \overline{MR} to clock ('162, '163)	Waveform 6	0		0		ns
t_{rec} Recovery time, \overline{MR} to CP	Waveform 3	25		15		ns

NOTE:

1. For 15ns rise time only, Hold time must be increased by 0.3ns for each nanosecond decrease in rise time.

Counters

74160, 74161, 74163, LS160A, LS161A, LS162A, LS163A

AC WAVEFORMS

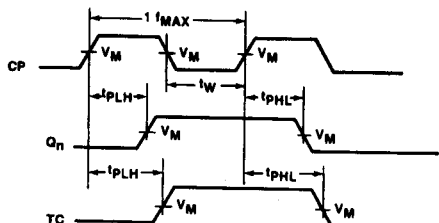

WF061715

$V_M = 1.5V$ for 74 and 74S; $V_M = 1.3V$ for 74LS.

Waveform 1. Clock To Output Delays, Maximum Frequency, and Clock Pulse Width

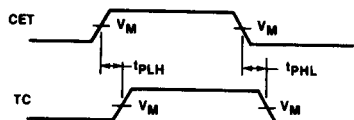

WF062305

$V_M = 1.5V$ for 74 and 74S; $V_M = 1.3V$ for 74LS.

Waveform 2. Propagation Delays CET Input To TC Output

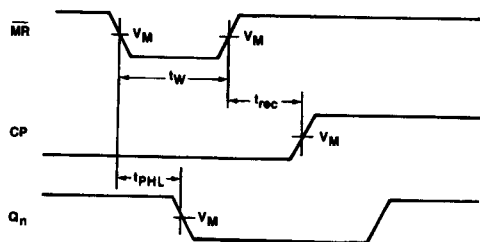

WF061955

$V_M = 1.5V$ for 74 and 74S; $V_M = 1.3V$ for 74LS.

Waveform 3. Master Reset Pulse Width, Master Reset To Output Delay and Master Reset To Clock Recovery Time ('160, '161)

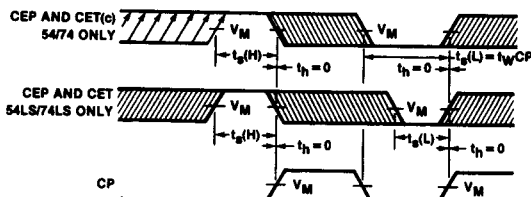

WF062505

$V_M = 1.5V$ for 74 and 74S; $V_M = 1.3V$ for 74LS.
The shaded areas indicate when the input is permitted to change for predictable output performance.

Waveform 2. CEP And CET Set-up And Hold Times

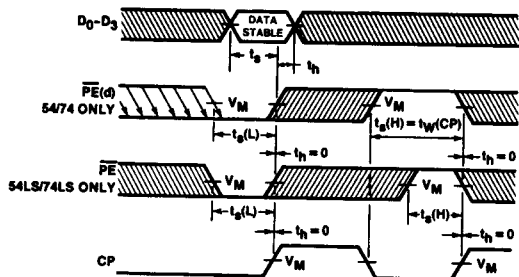

WF062805

$V_M = 1.5V$ for 74 and 74S; $V_M = 1.3V$ for 74LS.
The shaded areas indicate when the input is permitted to change for predictable output performance.

Waveform 5. Parallel Data And Parallel Enable Set-up And Hold Times

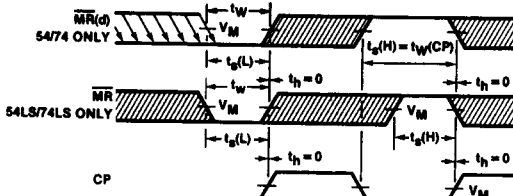

WF062705

$V_M = 1.5V$ for 74 and 74S; $V_M = 1.3V$ for 74LS.
The shaded areas indicate when the input is permitted to change for predictable output performance.

Waveform 6. Synchronous Reset Set-up, Pulse Width And Hold Times ('162, '163)