



MBR20xxCT, MBRF20xxCT & MBRB20xxCT Series

Vishay Semiconductors
formerly General Semiconductor

Dual Schottky Barrier Rectifier

Reverse Voltage 35 to 60V
Forward Current 20A

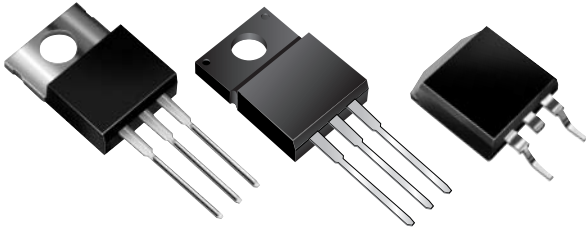

TO-220AB (MBR20xxCT)

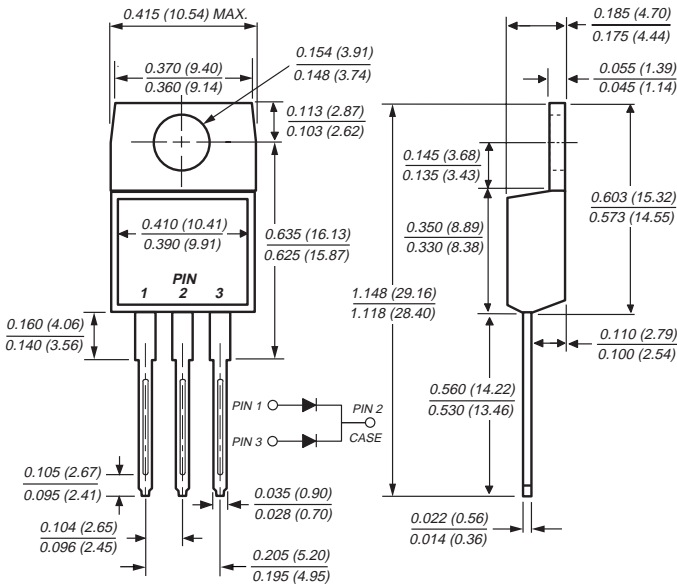

ITO-220AB (MBRF20xxCT)

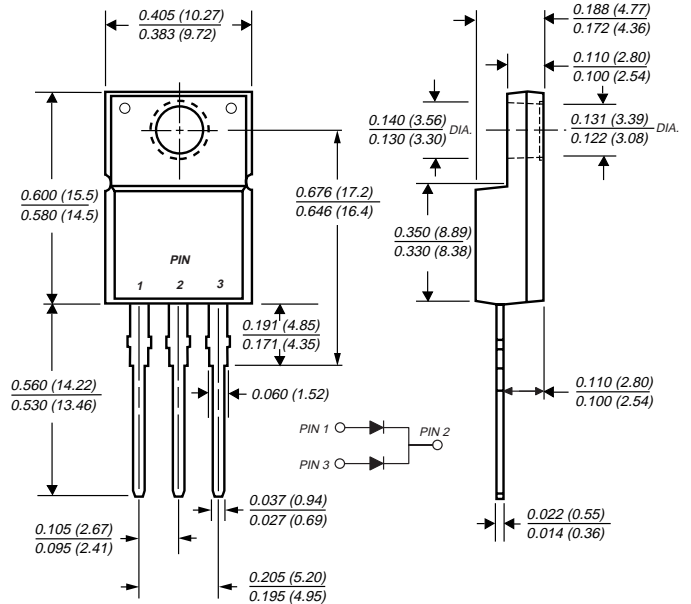

Mounting Pad Layout TO-263AB

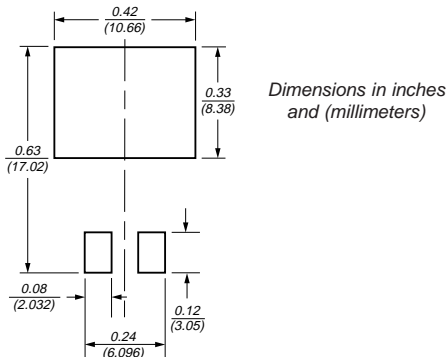

TO-263AB (MBRB20xxCT)

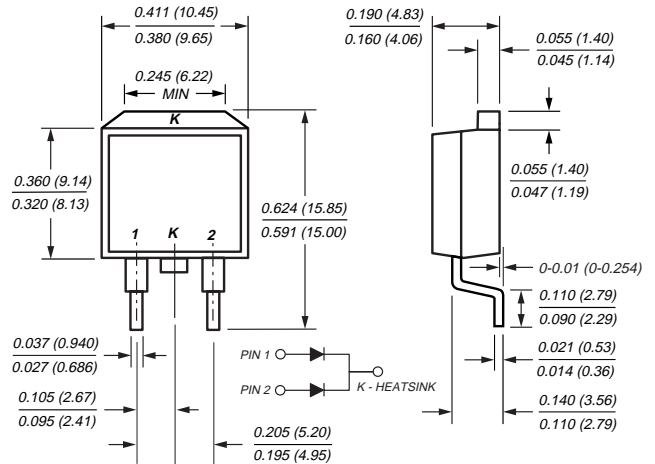

Features

- Plastic package has Underwriters Laboratory Flammability Classification 94V-0
- Dual rectifier construction, positive center tap
- Metal silicon junction, majority carrier conduction
- Low power loss, high efficiency
- Guardring for overvoltage protection
- For use in low voltage, high frequency inverters, free wheeling, and polarity protection applications
- High temperature soldering guaranteed: 250°C/10 seconds, 0.25" (6.35mm) from case

Mechanical Data

Case: JEDEC TO-220AB, ITO-220AB & TO-263AB molded plastic body

Terminals: Plated leads, solderable per MIL-STD-750, Method 2026

Polarity: As marked

Mounting Position: Any

Mounting Torque: 10 in-lbs maximum

Weight: 0.08 oz., 2.24 g

MBR20xxCT, MBRF20xxCT & MBRB20xxCT Series



Vishay Semiconductors
formerly General Semiconductor

Maximum Ratings (T_C = 25°C unless otherwise noted)

Parameter	Symbol	MBR2035CT	MBR2045CT	MBR2050CT	MBR2060CT	Unit
Maximum repetitive peak reverse voltage	V _{RRM}	35	45	50	60	V
Working peak reverse voltage	V _{RWM}	35	45	50	60	V
Maximum DC blocking voltage	V _{DC}	35	45	50	60	V
Maximum average forward rectified current <i>Total device</i> at T _C = 135°C <i>Per leg</i>	I _{F(AV)}	20 10				A
Peak repetitive forward current per leg at T _C = 135°C (rated V _R , sq. wave 2.0 KHz)	I _{FRM}	20				A
Peak forward surge current 8.3ms single half sine-wave superimposed on rated load (JEDEC Method) per leg	I _{FSM}	150				A
Peak repetitive reverse surge current per leg at t _p = 2μs, 1KHz	I _{RRM}	1.0		0.5		A
Voltage rate of change (rated V _R)	dv/dt	10,000				V/μs
Operating junction temperature range	T _J	-65 to +150				°C
Storage temperature range	T _{STG}	-65 to +175				°C
RMS Isolation voltage (MBRF type only) from terminals to heatsink with t = 1.0 second, RH ≤ 30%	V _{ISOL}	4500 (NOTE 1) 3500 (NOTE 2) 1500 (NOTE 3)				V

Electrical Characteristics (T_C = 25°C unless otherwise noted)

Parameter	Symbol	MBR2035CT	MBR2045CT	MBR2050CT	MBR2060CT	Unit
Maximum instantaneous forward voltage per leg (Note 4) at I _F = 10A, T _C = 25°C at I _F = 10A, T _C = 125°C at I _F = 20A, T _C = 25°C at I _F = 20A, T _C = 125°C	V _F	-		0.80 0.70 0.95 0.85		V
Maximum reverse current per leg at rated DC blocking voltage (NOTE 4)	I _R	0.1 15		0.15 150		mA

Thermal Characteristics (T_C = 25°C unless otherwise noted)

Parameter	Symbol	MBR	MBRF	MBRB	Unit
Thermal resistance from junction to case per leg	R _{θJC}	2.0	5.0	2.0	°C/W

Notes:

- (1) Clip mounting (on case), where lead does not overlap heatsink with 0.110" offset
- (2) Clip mounting (on case), where leads do overlap heatsink
- (3) Screw mounting with 4-40 screw, where washer diameter is ≤ 4.9 mm (0.19")
- (4) Pulse test: 300μs pulse width, 1% duty cycle

Ordering Information

Product	Case	Package Code	Package Option
MBR2035CT - MBR2060CT	TO-220AB	45	Anti-Static tube, 50/tube, 2K/carton
MBRF2035CT - MBRF2060CT	ITO-220AB	45	Anti-Static tube, 50/tube, 2K/carton
MBRB2035CT - MBRB2060CT	TO-263AB	31	13" reel, 800/reel, 4.8K/carton
		45	Anti-Static tube, 50/tube, 2K/carton
		81	Anti-Static 13" reel, 800/reel, 4.8K/carton



Ratings and Characteristic Curves ($T_A = 25^\circ\text{C}$ unless otherwise noted)

Forward Current Derating Curve

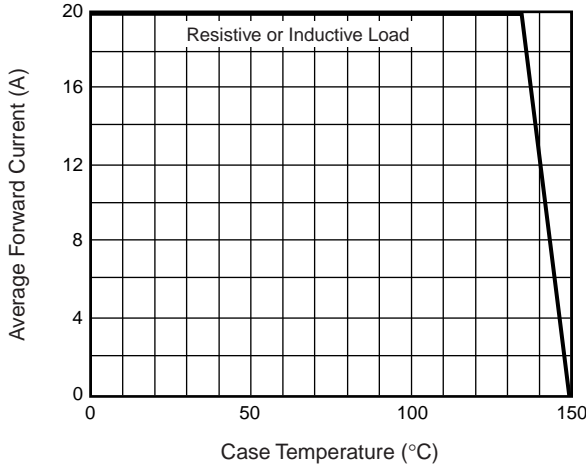

Maximum Non-Repetitive Peak Forward Surge Current Per Leg

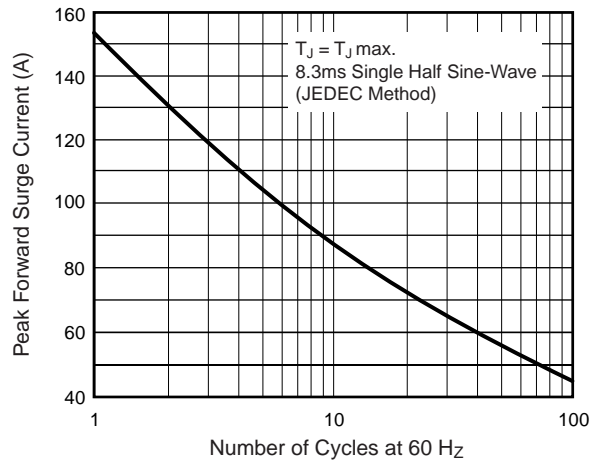

Typical Instantaneous Forward Characteristics Per Leg

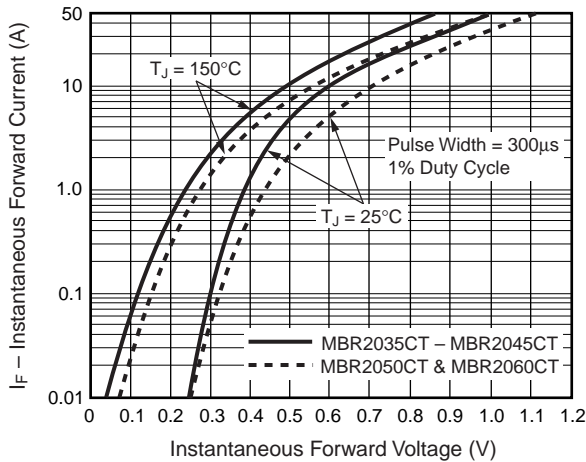

Typical Reverse Characteristics Per Leg

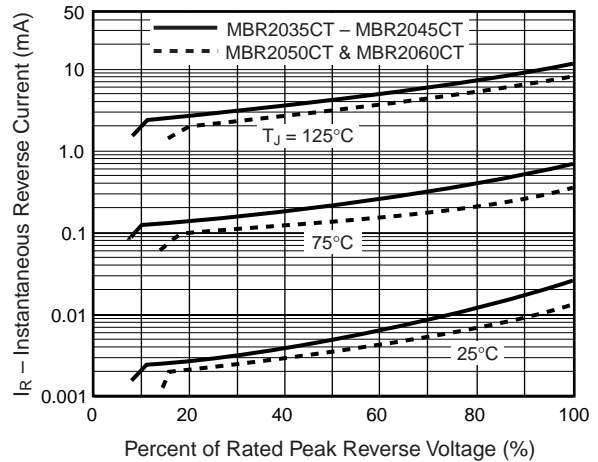

Typical Junction Capacitance Per Leg

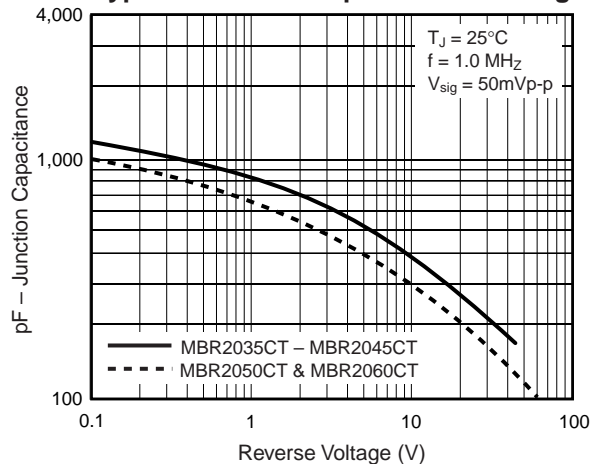

Typical Transient Thermal Impedance Per Leg

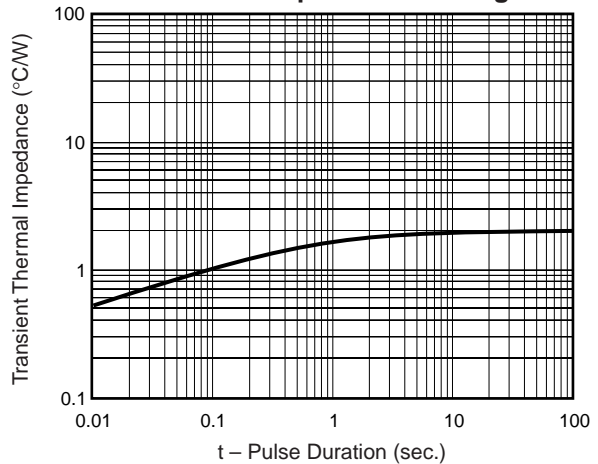



Notice

Specifications of the products displayed herein are subject to change without notice. Vishay Intertechnology, Inc., or anyone on its behalf, assumes no responsibility or liability for any errors or inaccuracies.

Information contained herein is intended to provide a product description only. No license, express or implied, by estoppel or otherwise, to any intellectual property rights is granted by this document. Except as provided in Vishay's terms and conditions of sale for such products, Vishay assumes no liability whatsoever, and disclaims any express or implied warranty, relating to sale and/or use of Vishay products including liability or warranties relating to fitness for a particular purpose, merchantability, or infringement of any patent, copyright, or other intellectual property right.

The products shown herein are not designed for use in medical, life-saving, or life-sustaining applications. Customers using or selling these products for use in such applications do so at their own risk and agree to fully indemnify Vishay for any damages resulting from such improper use or sale.