

Quad 2-Input OR Gate

This device contains four independent gates, each of which performs the logic OR function.

- AVG's LS operates over extended Vcc from 4.5 to 5.5 V
- AVG's LS and ALS both have guaranteed DC and AC specification over full temperature and Vcc range
- Switching specifications for ALS at 50 pF
- AVG's ALS has the lowest speed power product (4pJ per gate typical) of all logic series

DV74LS32
DV74ALS32

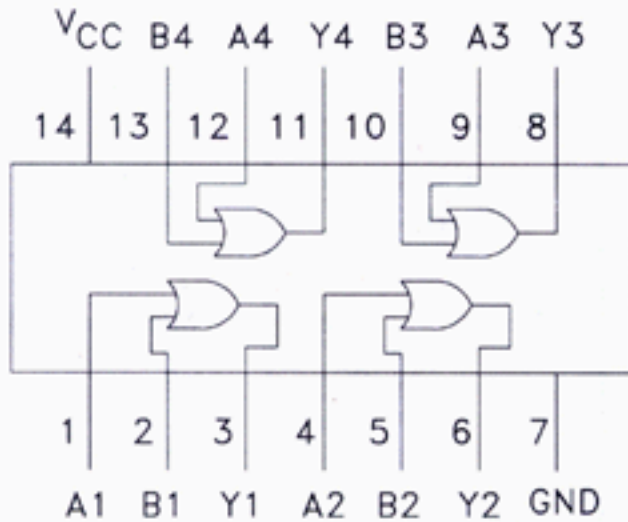
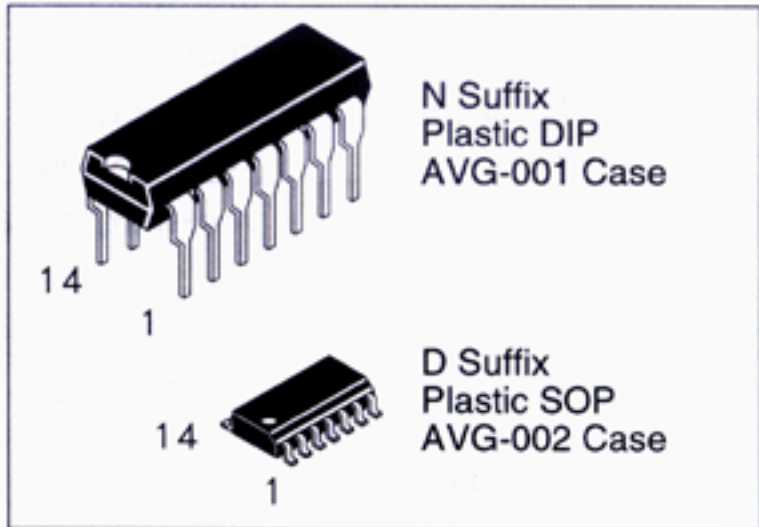

TRUTH TABLE
Y = A + B

Inputs		Outputs
A	B	Y
H	X	H
X	H	H
L	L	L

H=High Logic Level
L=Low Logic Level
X=Don't Care

ABSOLUTE MAXIMUM RATINGS

Maximum ratings are those values beyond which damage to the device may occur.

Symbol	Parameter	LS32	ALS32	Unit
V _{CC}	Supply Voltage	7.0	7.0	V
V _{IN}	Input Voltage	7.0	7.0	V
T _{STG}	Storage Temperature Range	-65 to +150	-65 to + 150	°C

GUARANTEED OPERATING CONDITIONS

Symbol	Parameter	LS32		ALS32		Unit
		Min	Max	Min	Max	
V _{CC}	Supply Voltage	4.5	5.5	4.5	5.5	V
V _{IH}	High Level Input Voltage	2.0		2.0		V
V _{IL}	Low Level Input Voltage		0.8		0.8	V
I _{OH}	High Level Output Current		-0.4		-0.4	mA
I _{OL}	Low Level Output Current		8.0		8.0	mA
T _A	Ambient Temperature Range	-10 to +70		-10 to + 70		°C

DC ELECTRICAL CHARACTERISTICS over full operating conditions

Symbol	Parameter	Conditions	LS32			ALS32			Unit
			Min	Typ	Max	Min	Typ	Max	
V_{IK}	Input Clamp Voltage	$V_{CC} = \text{min}, I_{IN} = -18 \text{ mA}$			-1.5			-1.5	V
V_{OH}	High Level Output Voltage	$V_{CC} = \text{min}, I_{OH} = \text{max}$	$V_{CC}-2$	3.5		$V_{CC}-2$			V
V_{OL}	Low Level Output Voltage	$V_{CC} = \text{min}; I_{OL} = 4 \text{ mA}$ $V_{CC} = \text{min}; I_{OL} = 8 \text{ mA}$		0.25 0.35	0.4 0.5		0.25 0.35	0.4 0.5	V
I_{IH}	High Level Input Current	$V_{CC} = \text{max}, V_{IN} = 2.7 \text{ V}$ $V_{CC} = \text{max}, V_{IN} = 7 \text{ V}$			20 0.1			20 0.1	μA mA
I_{IL}	Low Level Input Current	$V_{CC} = \text{max}, V_{IN} = 0.4 \text{ V}$			-0.4			-0.1	mA
I_o	Short Circuit Current	$V_{CC} = \text{max}, V_O = 2.25 \text{ V}$	-20		-110	-30		-112	mA
I_{CC}	Supply Current Outputs High Outputs Low	$V_{CC} = \text{Max}$			6.2 9.8		1.9 2.6	4.0 4.9	mA mA

SWITCHING CHARACTERISTICS over full operating conditions

Symbol	Parameter	LS32 $C_L = 15 \text{ pF}$		ALS32 $C_L = 50 \text{ pF}$ $R_L = 500 \Omega$		Unit
		Min	Max	Min	Max	
t_{PLH}	Turn Off Delay, Input to Output Low to High Level Output		22	3	14	ns
t_{PHL}	Turn On Delay, Input to Output High to Low Level Output		22	3	12	ns

SWITCHING WAVEFORMS