

PRODUCT NUMBER
SEE NOTE 1

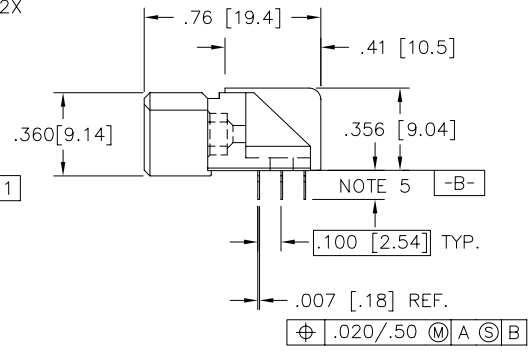
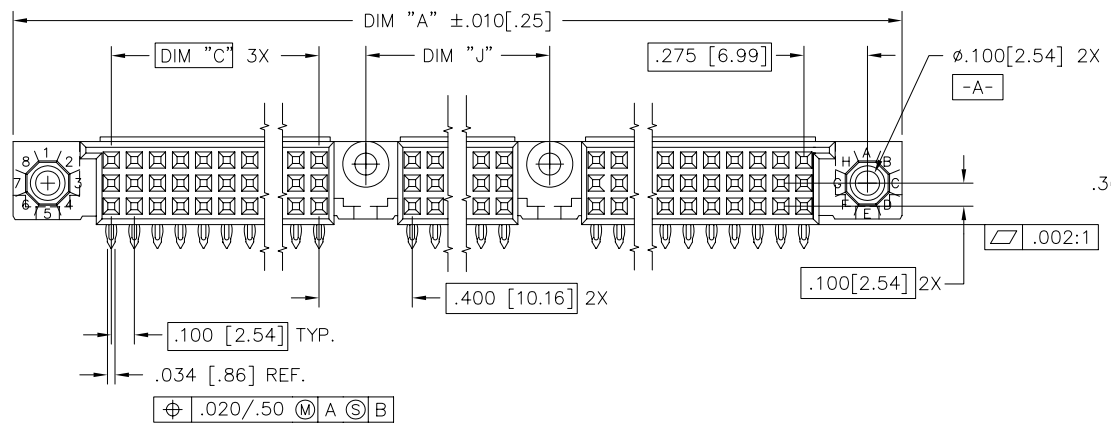
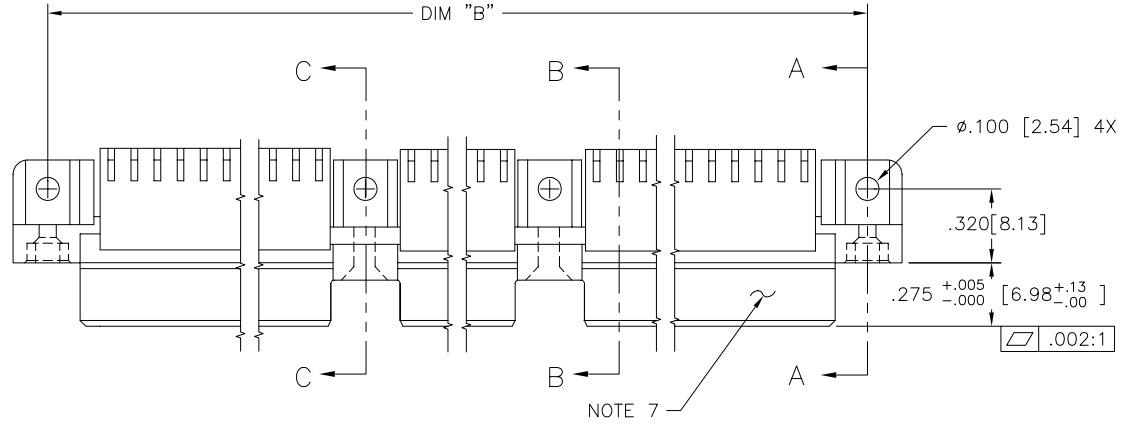

FCIconnect.com

Copyright FCI

mat'l. code		surface		tolerance		projection		product family	
-		ISO 1302 ✓		ISO 406 ISO 1101				HPC	
ltr		ecn no		date		tolerances unless otherwise specified		title	
G	V40739	GIP	4/12/94	angles	linear	.xx±.01/.3		3 ROW R/A RECEPT. PRESS FIT, 2 GUIDE PINS	
H	V41510	GAH	10/13/94			.xxx±.005/.13		dwg no	
J	V60822	GIP	5/30/96	0°±2'		.xxxx±.0020/.051		sheet 1 of 3 size	
K	V90001	HTB	2/15/99	dr	G.PETERS	6/19/93		A3	
L	V00270	JWS	1/31/00	enr	S.CLARK	6/19/93		50647	
M	V10828	JRW	02/28/01	chr	S.CLARK	6/19/93		type Product Customer Drawing	
N	M06-0255	MHT	7/06/06	appd	S.CLARK	6/19/93			
sheet	revision	N	N	N					
index	sheet	1	2	3					

form: A3

PRODUCT NUMBER	DIM	LENGTH FORMULAS
SEE NOTE 1	DIM "A"	.100 [2.54] x NO. of COLUMNS + 1.35 [34.3]
	DIM "B"	.100 [2.54] x NO. of COLUMNS + 1.050 [26.67]
	DIM "C"	.100 [2.54] x NO. of COLUMNS DIVIDED BY 3 - .100 [2.54]
	DIM "J"	.100 [2.54] x NO. of COLUMNS DIVIDED BY 3 - .300 [7.67]

NOTES:

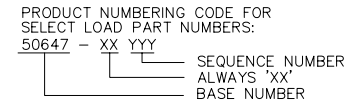
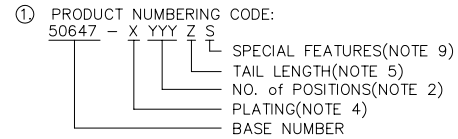

② THIS PRODUCT IS CONFIGURED IN SIZES OF 30 thru 150 COLUMNS IN INCREMENTS OF THREE.
 i.e.: 30,33,36,.....147,150.

③ PRESS BLOCK MATERIAL: LCP.
 HOUSING MATERIAL: GLASS AND MINERAL FILLED HIGH TEMP. THERMOPLASTIC. FLAME RETARDANT PER UL94V-0. COLOR: BLACK.
 CONTACT MATERIAL: BeCu.

④ PLATING, CONTACT AREA OPTIONS.
 1=30u"/.76u" GOLD
 ALL TAILS TIN/LEAD.

⑤ TAIL LENGTH OPTIONS:
 E = .125±.010 [3.18±.25]
 F = .145±.010 [3.68±.25]

⑥ DRILLED HOLE DIA. OF .0453±.001 FINISHED TO .0400±.0030 BY PLATING SnPb(60/40) .0003-.0006 w/Cu UNDERPLATE AS NEEDED.

⑦ MANUFACTURE'S LOGO, P/N, AND LOT CODE TO APPEAR ON THIS SURFACE.

8. FOR DOCUMENTATION MENU, SEE SPECIFICATION BUS-01-057.

⑨ SPECIAL FEATURES:

- = IF NO SPECIAL FEATURE CODE IS SELECTED, CONNECTOR WILL APPEAR AS SHOWN. PCB MOUNTING HOLE DIMENSION TO BE $\phi.120\pm.003$ [3.05±0.07]
- "A" = IF SPECIFIED, CONNECTOR WILL APPEAR AS SHOWN ON SHEET 3. PCB MOUNTING HOLE DIMENSION TO BE $\phi.100\pm.003$ [2.54±0.07]
- "B" = IF SPECIFIED, CONNECTOR WILL HAVE PRE-INSTALLED EYELET FOR P.C.B. ATTACHMENT IN A $\phi.100\pm.003$ [2.54±0.07] MOUNTING HOLE. SEE SHEET 3. (AVAILABLE IN "E" TAIL LENGTH. ONLY).
- "C" = IF SPECIFIED, CONNECTOR WILL HAVE PRE-INSTALLED EYELET FOR P.C.B. ATTACHMENT IN A $\phi.120\pm.003$ [3.05±0.07] MOUNTING HOLE. SEE SHEET 3.

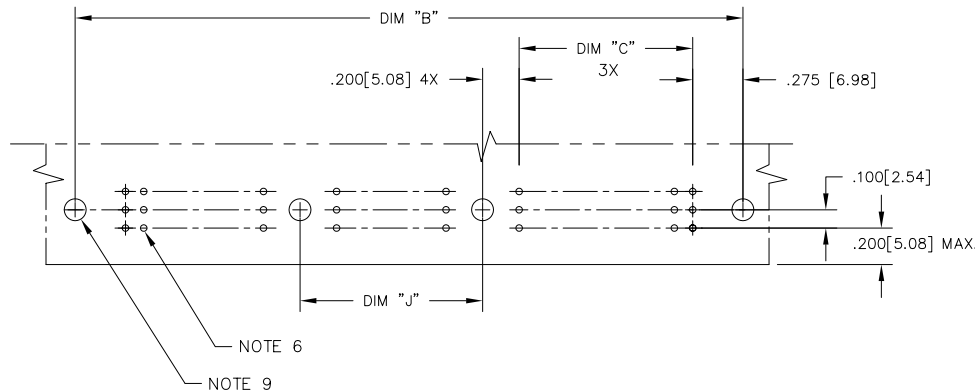
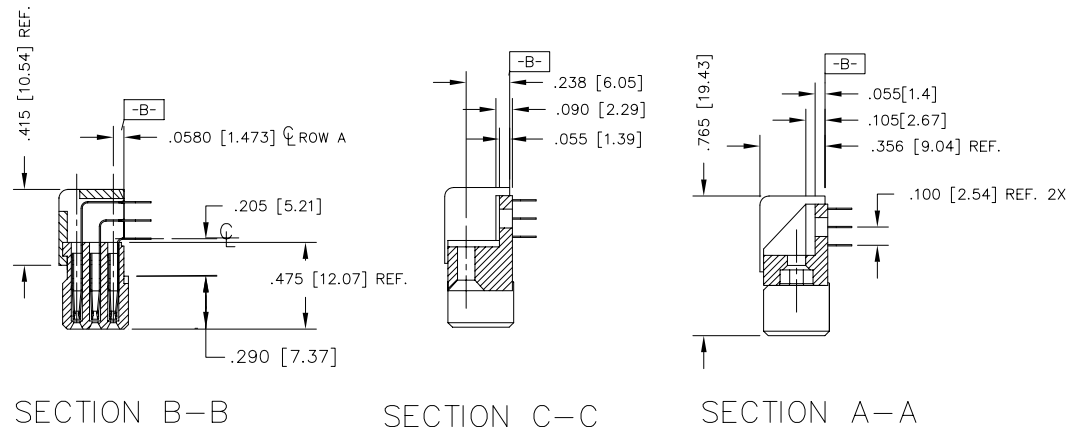

RECOMMENDED PCB LAYOUT
 (ALL HOLES LOCATED ON .100[2.54] GRID UNLESS OTHERWISE SHOWN)

mat'l. code		surface		tolerance		projection		product family	
-		ISO 1302 ✓		ISO 406		⊕		HPC	
ISO 1101		tolerances unless otherwise specified		.xx±.01/.3		INCH/MM		title	
N		angles		.xxx±.005/.13		scale 1:1		3 ROW R/A RECEPT. PRESS FIT, 2 GUIDE PINS	
		0°±2'		.xxxx±.0020/.051		FCI		dwg no sheet 2 of 3 size	
		dr		G.PETERS 6/19/93				50647 A3	
		enrg		S.CLARK 6/19/93				type Product Customer Drawing	
		chr		S.CLARK 6/19/93					
		appd		S.CLARK 6/19/93					
sheet index		revision sheet							

PRODUCT NUMBER
SEE NOTE 1

SPECIAL FEATURE OPTION A

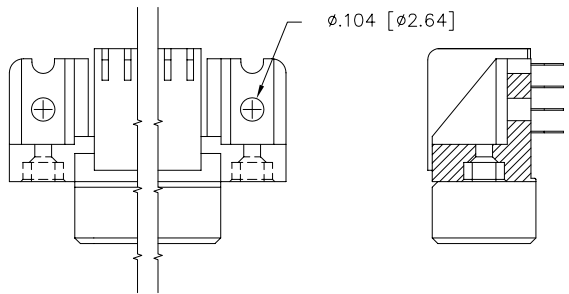

SECTION A-A

SPECIAL FEATURE OPTION B

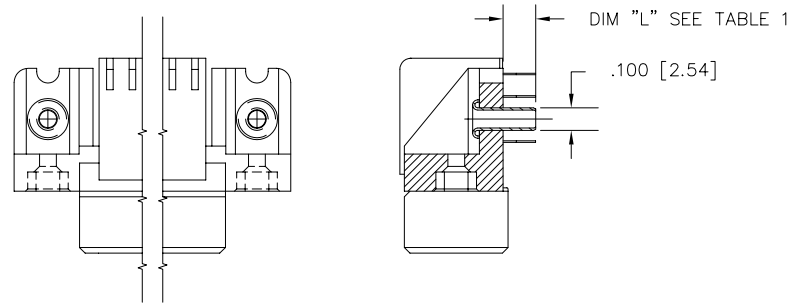

SECTION A-A

SPECIAL FEATURE OPTION C

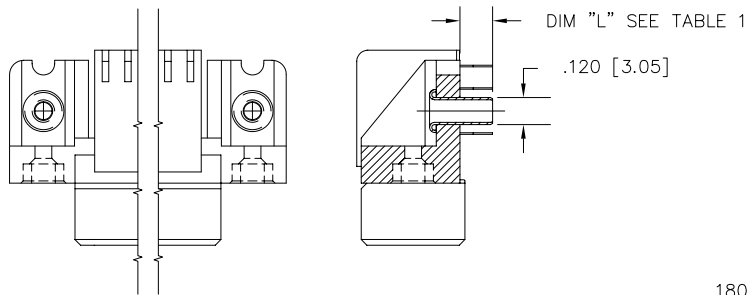

SECTION A-A

SPECIAL FEATURE OPTION D

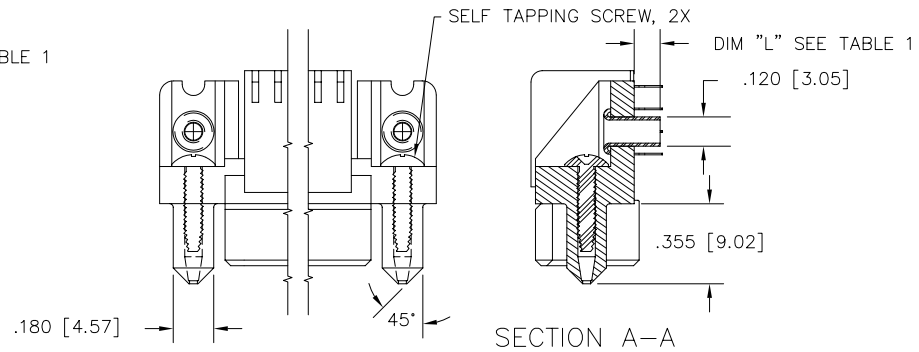

SECTION A-A

TABLE 1

SPECIAL FEATURE	TAIL LENGTH	DIM "L"
"B"	E	.145 [3.68]
	-	-
"C"	E	.115 [2.92]
	F	.145 [3.68]
"D"	E	.115 [2.92]
	F	.145 [3.68]

mat'l. code		surface		tolerance		projection		product family	
-		ISO 1302		ISO 406		ISO 1101		HPC	
ltr		ecn		no		dr		date	
N									
		angles		linear		.XX±.01/.3		INCH/MM	
		0°±2'				.XXX±.005/.13		scale 1:1	
						.XXXX±.0020/.051		dwg no	
		dr		G.PETERS		6/19/93		sheet 3 of 3 size	
		enr		S.CLARK		6/19/93		50647 A3	
		chr		S.CLARK		6/19/93		type	
		appd		S.CLARK		6/19/93		Product Customer Drawing	
sheet index		revision sheet							