

Low I_Q , Low Dropout 500mA Fixed Voltage Regulator

Features

- Low Noise : $50\mu V_{RMS}$ (100Hz to 100kHz)
- Low Quiescent Current : $50\mu A$ (No load)
- Low Dropout Voltage : 170mV (@500mA)
- Very low Shutdown Current : $< 0.5\mu A$
- Fixed Output Voltage : 1.3V ~ 3.4V
- Stable with 4.7 μF Output Capacitor
- Stable with Aluminum, Tantalum or Ceramic Capacitors
- Reverse Current Protection
- No Protection Diodes Needed
- Built-in Thermal Protection
- Built-in Current Limit Protection
- Controlled Short Circuit Current : 150mA
- Fast Transient Response
- Short Setting Time
- SOT-23-5, SOT-89, SOT-89-5, SOT-223, SOP-8, TO-252 and TO-252-5 Packages
- Lead Free Available (RoHS Compliant)

Design with an internal P-channel MOSFET pass transistor, the APL5501/2/3 maintains a low supply current, independent of the load current and dropout voltage. Other features include reverse current protection, thermal-shutdown protection, current limit protection to ensure specified output current and controlled short-circuit current. The APL5501/2/3 regulator comes in a miniature SOT-23-5, SOT-89, SOT-89-5, SOT-223, SOP-8, TO-252 and TO-252-5 packages.

Pin Configuration

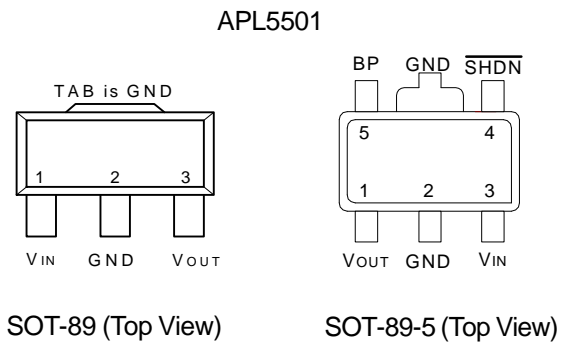

Applications

- Notebook Computer
- PDA or Portable Equipments
- Noise-Sensitive Instrumentation Systems

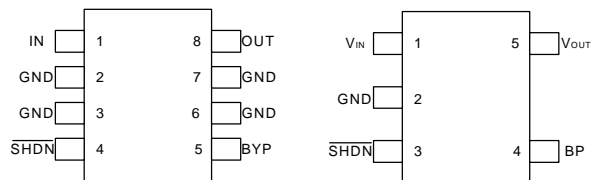

General Description

The APL5501/2/3 is micropower, low noise, low dropout linear regulator. Operate from 2.7V to 6V input voltage and deliver up to 500mA. Typical output noise is just $50\mu V_{RMS}$ with the addition of an external 0.1 μF bypass capacitor in BP pin and typical dropout voltage is only 170mV at 500mA loading. Designed for use in battery-powered system, the low $50\mu A$ quiescent current makes it an ideal choice.

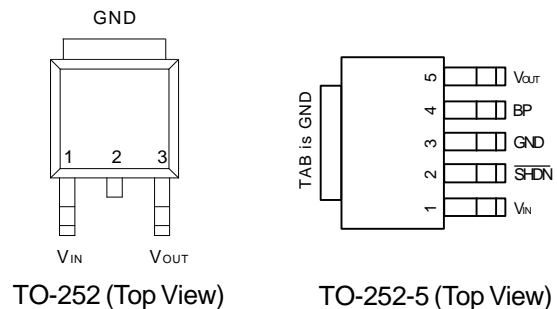

ANPEC reserves the right to make changes to improve reliability or manufacturability without notice, and advise customers to obtain the latest version of relevant information to verify before placing orders.

Pin Configuration (Cont.)

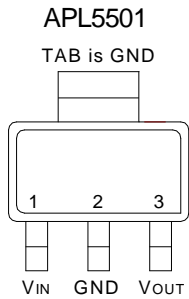

SOT-223 (Top View)

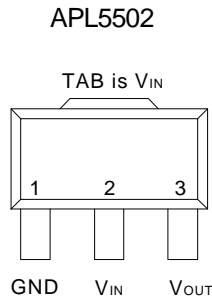

SOT-89 (Top View)

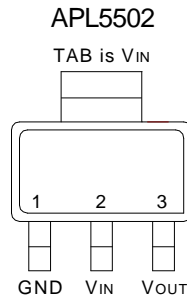

SOT-223 (Top View)

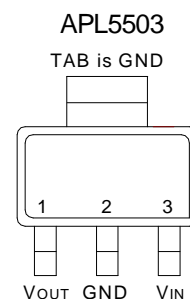

SOT-223 (Top View)

Ordering and Marking Information

<p>APL5501/2/3 □□□□-□□□</p> <ul style="list-style-type: none"> □ □ □ □ - Lead Free Code □ □ □ - Handling Code □ □ - Temp. Range □ - Package Code □ - Voltage Code 	<p>Package Code B : SOT-23-5 D : SOT-89 D5 : SOT-89-5 U : TO-252 U5 : TO-252-5 V : SOT-223 K : SOP-8 Temp. Range C : 0 to 70 °C Handling Code TR : Tape & Reel Voltage Code : 13 : 1.3V ~ 34 : 3.4V Lead Free Code L : Lead Free Device</p>
<p>APL5501/2/3 - 13 D/V/K : APL5501/2/3 XXXXX13</p>	<p>XXXXX - Date Code , 13 - 1.3V</p>
<p>APL5501/2/3 - 13 U :  13 APL5501/2/3 XXXXX</p>	<p>XXXXX - Date Code , 13 - 1.3V</p>

Note: ANPEC lead-free products contain molding compounds/die attach materials and 100% matte in plate termination finish; which are fully compliant with RoHS and compatible with both SnPb and lead-free soldering operations. ANPEC lead-free products meet or exceed the lead-free requirements of IPC/JEDEC J STD-020C for MSL classification at lead-free peak reflow temperature.

Marking Information

SOT-23-5 package

Product Name	Marking	Product Name	Marking	Product Name	Marking
APL5501-13B	517X	APL5501-21B	51FX	APL5501-28B	51MX
APL5501-14B	518X	APL5501-22B	51GX	APL5501-29B	51NX
APL5501-15B	519X	APL5501-23B	51HX	APL5501-30B	51OX
APL5501-16B	51AX	APL5501-24B	51IX	APL5501-31B	51PX
APL5501-17B	51BX	APL5501-25B	51JX	APL5501-32B	51QX
APL5501-18B	51CX	APL5501-26B	51KX	APL5501-33B	51RX
APL5501-19B	51DX	APL5501-27B	51LX	APL5501-34B	51SX
APL5501-20B	51EX				

The last character "X" in the marking is for data code.

Pin Description

PIN		I/O	Description
No.	Name		
1	V _{IN}	I	Supply voltage input.
3	SHDN ^(Note1)	I	Shutdown control pin, low = off , high = normal. Don't leave open.
2	GND		Ground pins of the circuitry, and all ground pins must be soldered to PCB with proper power dissipation.
4	BP ^(Note1)	O	Bypass signal pin in fixed output type device
5	V _{OUT}	O	Output pin of the regulator.

Note1: These pins do not exist in 3-pin package.

Absolute Maximum Ratings

Symbol	Parameter	Rating	Unit
V _{IN} , V _{OUT}	Input Voltage or Out Voltage	6.5	V
SHDN	Shutdown Control Pin	6.5	V
R _{TH,JA}	Thermal Resistance - Junction to Ambient	SOT-89 : 180 SOT-223 : 135 SOP-8 : 150 SOT-23-5 : 260	°C/W
R _{TH,JC}	Thermal Resistance - Junction to Case	SOT-89 : 38 SOT-223 : 15 SOP-8 : 20 SOT-23-5 : 130	°C/W
P _D	Power Dissipation	Internally Limited	W
T _J	Operating Junction Temperature		°C
	Control Section	0 to 125	
	Power Transistor	0 to 150	
T _{STG}	Storage Temperature Range	-65 to +150	°C
T _L	Lead Temperature (Soldering, 10 second)	260	°C

Electrical Characteristics

Unless otherwise noted these specifications apply over full temperature, V_{IN}=3.6V, C_{IN}=1μF, C_{OUT}=4.7μF, SHDN=V_{IN}, T_J=0 to 125°C. Typical values refer to T_J=25°C.

Symbol	Parameter	Test Conditions	APL5501/2/3			Unit
			Min.	Typ.	Max.	
V _{IN}	Input Voltage		2.7		6	V
V _{OUT}	Output Voltage	V _{OUT} +1.0V < V _{CC} < 6.0V, 0mA < I _{OUT} < I _{MAX}	V _{OUT} -2%	V _{OUT}	V _{OUT} +2%	V

Electrical Characteristics

Unless otherwise noted these specifications apply over full temperature, $V_{IN}=3.6V$, $C_{IN}=1\mu F$, $C_{OUT}=4.7\mu F$, $SHDN=V_{IN}$, $T_J=0$ to $125^\circ C$. Typical values refer to $T_J=25^\circ C$.

Symbol	Parameter	Test Conditions	APL5501/2/3			Unit
			Min.	Typ.	Max.	
I_{LIMIT}	Circuit Current Limit	$V_{IN}=4.3V$		0.7		A
I_{SHORT}	Short Current	$V_{OUT}=0V$		200		mA
I_{OUT}	Load Current		500			mA
REG_{LINE}	Line Regulation	$V_{OUT}+0.5V < V_{CC} < 6.0V$, $I_{OUT} = 1mA$		4	10	mV
REG_{LOAD}	Load Regulation	$V_{IN} = V_{OUT} + 1.0V$, $0mA < I_{OUT} < I_{MAX}$		1	6	mV
V_{DROP}	Dropout Voltage ^(Note2)	$I_{OUT} = 500mA$	$1.3V \leq V_{OUT} < 1.5V$	1100	1300	mV
			$1.5V \leq V_{OUT} < 2V$	900	1050	
			$2V \leq V_{OUT} < 2.5V$	500	700	
			$2.5V \leq V_{OUT} < 3.4V$	280	380	
PSRR	Ripple Rejection	$F \leq 1kHz$, $1V_{pp}$ at $V_{IN} = V_{OUT} + 1.0V$	55	65		dB
I_Q	Quiescent Current	No load		50	100	μA
		$I_{OUT}=500mA$		370	450	
	Shutdown Supply Current ^(Note3)	Shutdown = low $I_{OUT}=0$, $V_{CC} = 6.0V$		0.01	1	μA
	Noise ^(Note3)	$100Hz < f < 100kHz$, typical load, $C_{BP}=0.01\mu F$, $C_{OUT} = 1\mu F$		50		μV_{rms}
		$100Hz < f < 100kHz$, typical load, $C_{BP}=0.1\mu F$, $C_{OUT} = 1\mu F$		40		
	Shutdown Recovery Delay ^(Note3)	$C_{BP}=0.01\mu F$, $C_{OUT}=1\mu F$, no load		7		ms
		$C_{BP}=0.1\mu F$, $C_{OUT}=1\mu F$, no load		70		
OTS	Over Temperature Shutdown			150		$^\circ C$
	Over Temperature Shutdown Hysteresis	Hysteresis		10		$^\circ C$
TC	Output Voltage Temperature Coefficient			50		ppm/ $^\circ C$
C_{OUT}	Output Capacitor		4.2	4.7	5.2	μF
	ESR		0.02	0.1	1	Ohm
	Shutdown Input Threshold ^(Note3)	$V_{OUT} + 1.0V < V_{IN} < 6.0V$	0.4	0.7	1.6	V
I_{SHDN}	Shutdown input Bias current ^(Note3)	$V_{SHDN} = V_{IN}$		0.01	100	nA
	Input Reverse Leakage current	$V_{OUT} - V_{IN} = 0.1V$		0.1	0.5	μA
	Reverse Protection Threshold			11	50	mV

Note 2 : Dropout voltage definition : $V_{IN}-V_{OUT}$ when V_{OUT} is 2% below the value of V_{OUT} for $V_{IN} = V_{OUT} + 0.5V$

Note 3 : For 5-pin devices only.

Application Circuit

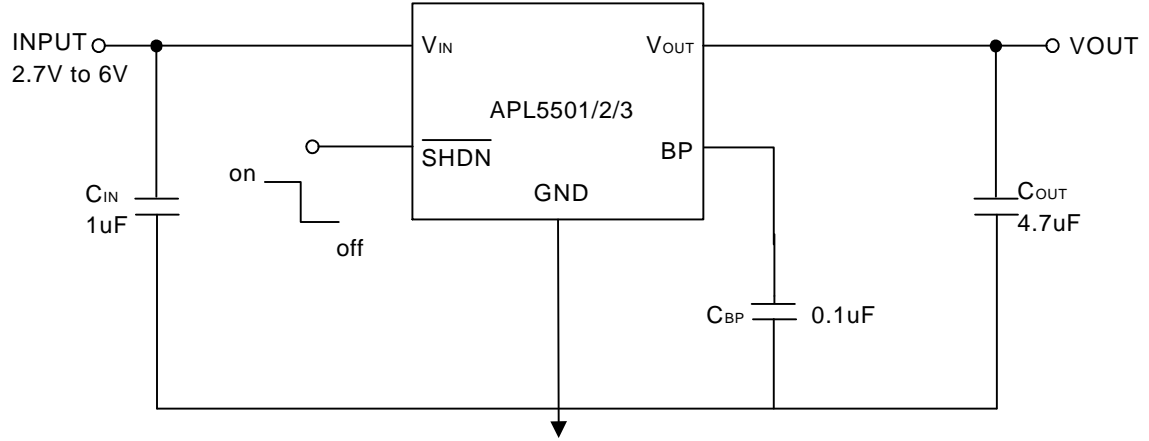

Typical Characteristics

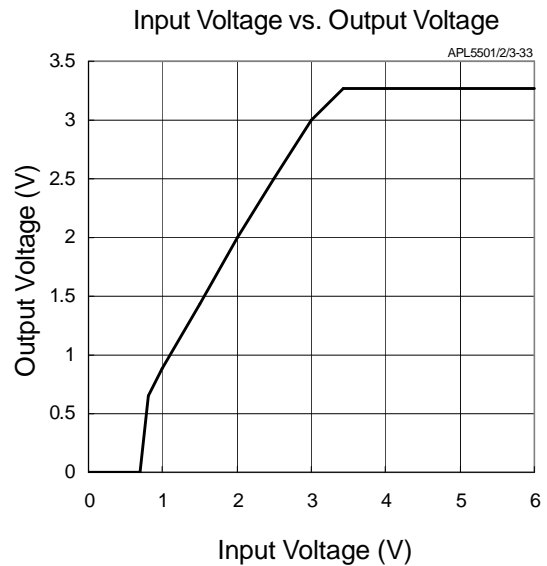
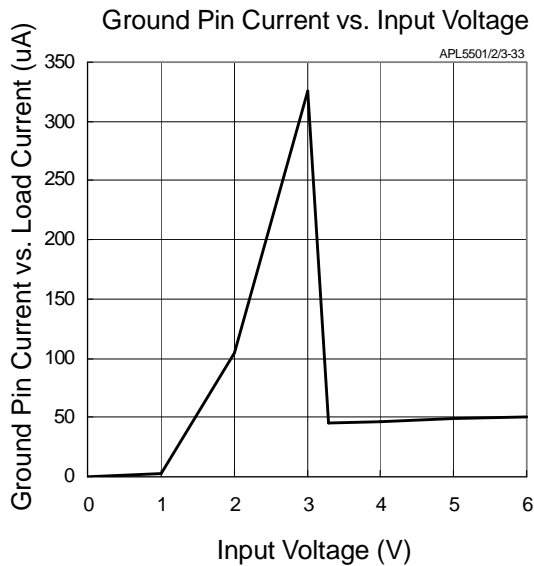
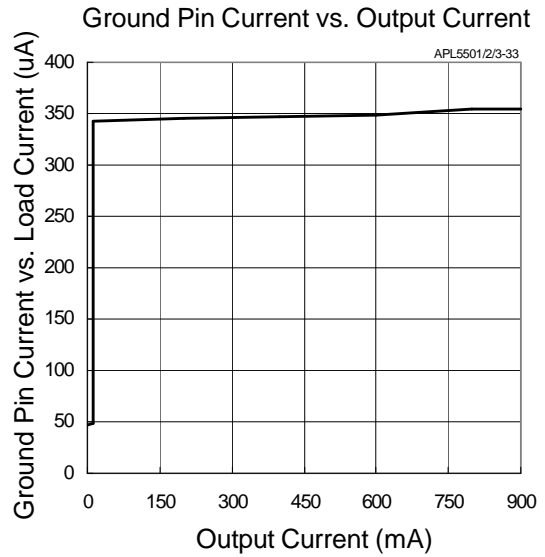
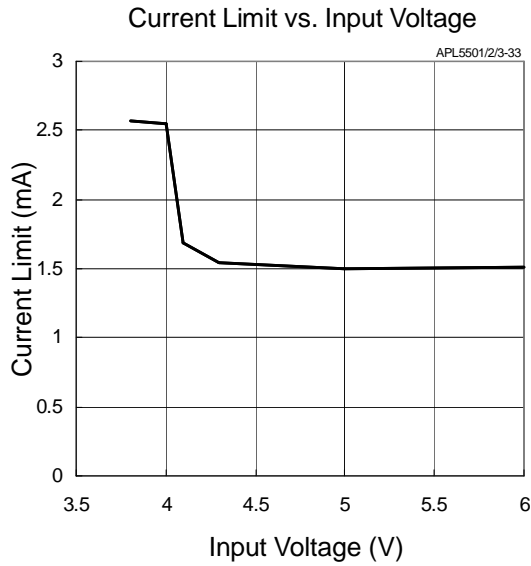

Typical Characteristics

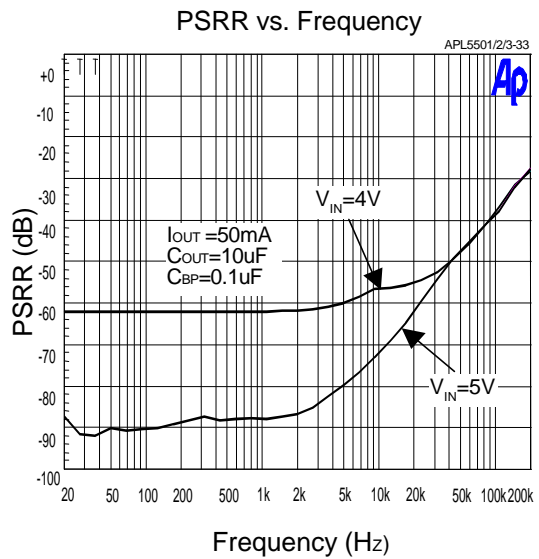
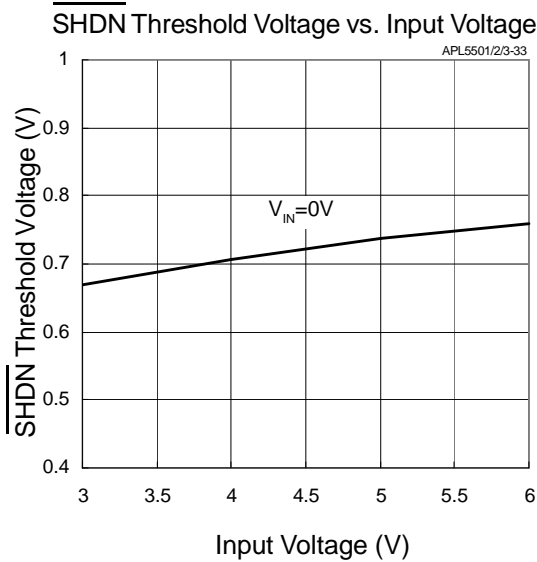
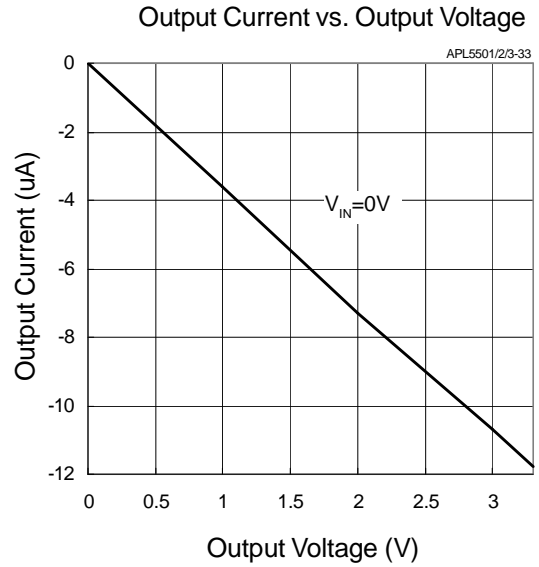
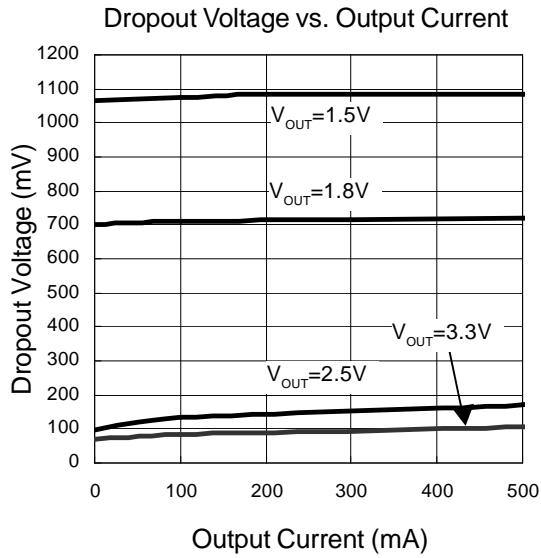

Typical Characteristics

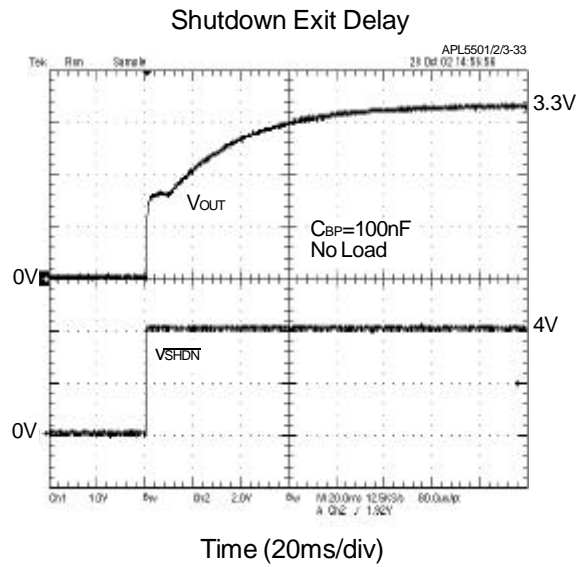
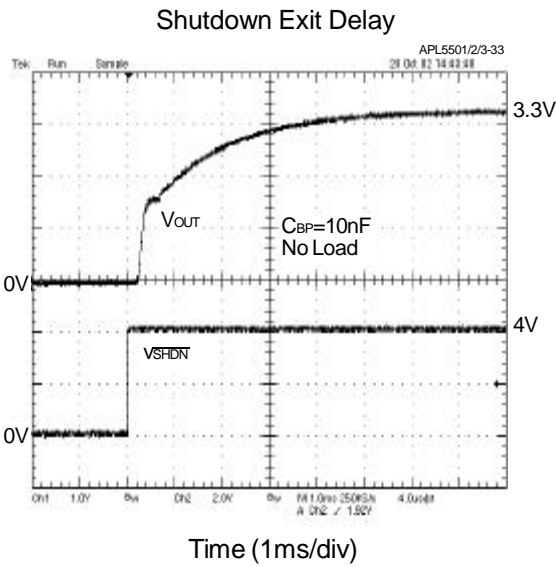
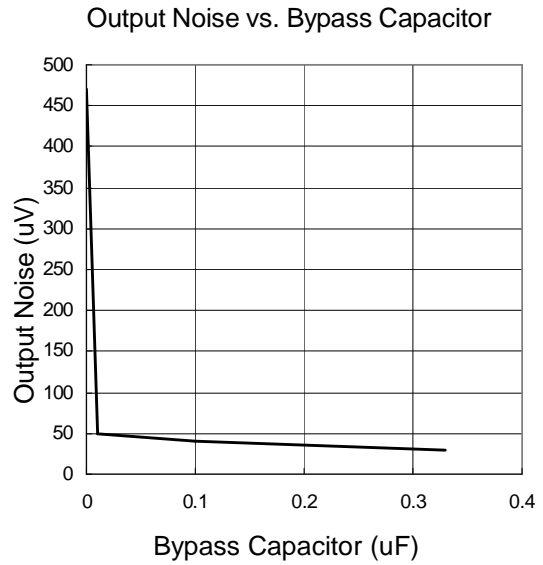
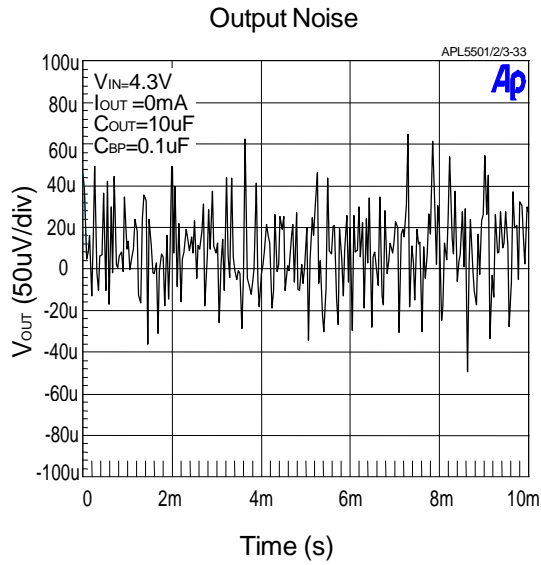

Typical Characteristics

Entering Shutdown

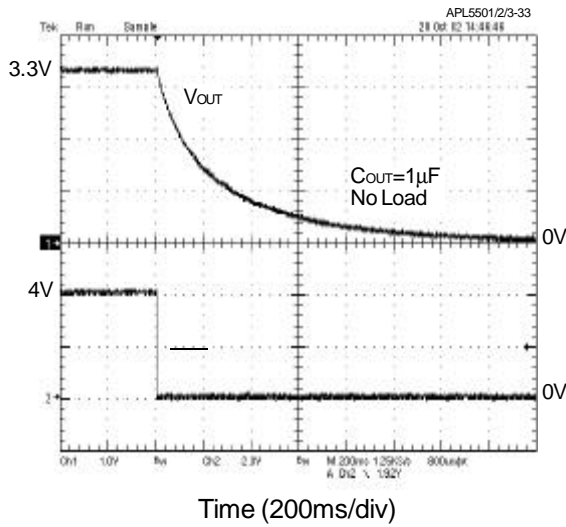

Region of Stable ESR vs. Load Current

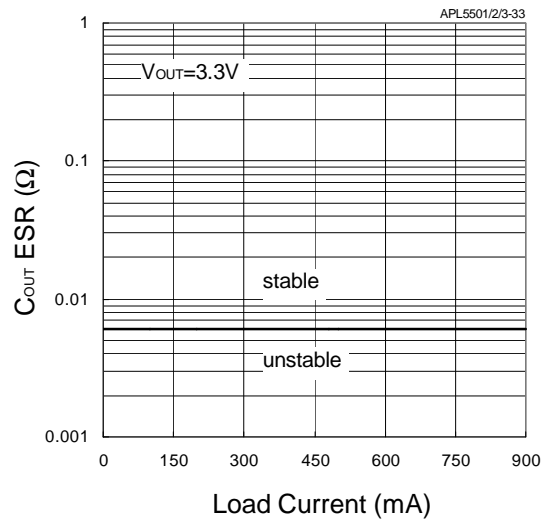

Output Voltage vs. Temperature

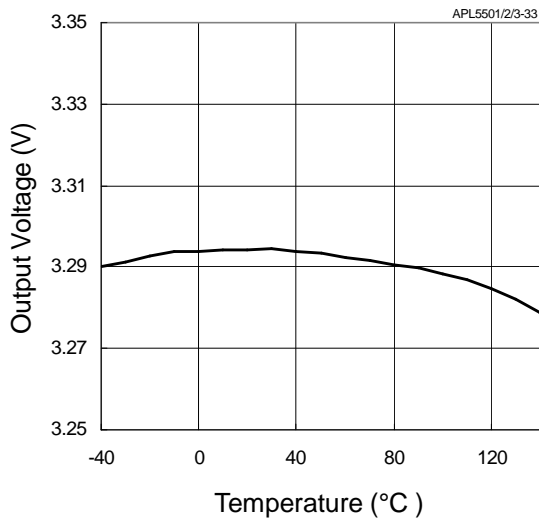

Line-Transient Response

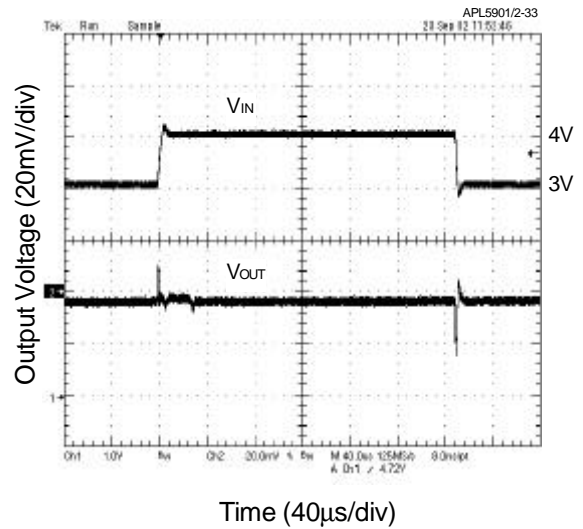

Typical Characteristics

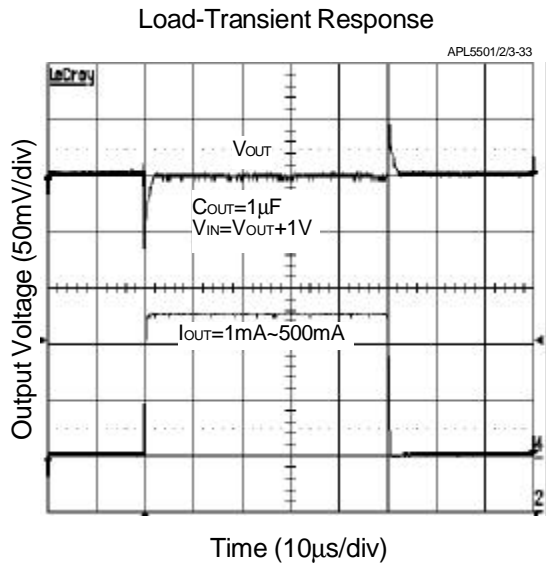

Application Information

Capacitor Selection and Regulator Stability

The APL5501/2/3 uses at least a $1\mu\text{F}$ capacitor on the input, and this capacitor can be Aluminum, Tantalum or Ceramic capacitor. The input capacitor with larger value and lower ESR provides better PSRR and line-transient response. The output capacitor also can use Aluminum, Tantalum or Ceramic capacitor, and a minimum value of $1\mu\text{F}$ and ESR above 0.06Ω is recommended. The curve of the stable region in typical characteristics shows the appropriate output capacitor ESR for different load current stable operation. A larger output capacitor can reduce noise and improve load-transient response, stability, and PSRR. Note that some ceramic dielectrics exhibit large capacitance and ESR variation with temperature. When using this capacitor, a minimum $10\mu\text{F}$ or more may be required to ensure the stability at low temperature operation. Use a bypass capacitor at BP pin for low output noise. Increasing the capacitance will slightly decrease the output noise, but increase the start-up time.

Load-Transient Considerations

The APL5501/2/3 load-transient response graphs in typical characteristics show the transient response. A step change in the load current from 0mA to 500mA at $1\mu\text{s}$ will cause a 100mV transient spike. Larger output capacitor and lower ESR can reduce transient spike.

Input-Output (Dropout)Voltage

The minimum input-output voltage difference (dropout) determines the lowest usable supply voltage. In battery-powered systems, this will determine the useful

end-of-life battery voltage. Because the APL5501/2/3 uses a p-channel MOSFET pass transistor, the dropout voltage is a function of drain-to-source on-resistance ($R_{\text{DS(ON)}}$) multiplied by the load current.

Reverse Current Protection

The APL5501/2/3 has an internal reverse protection, it does not need an external Schottky diode to connect the regulator input and output. If the output voltage is forced above the input voltage by more than 11mV , the IC will be shutdown and the ground pin current is below $0.1\mu\text{A}$.

Shutdown/Enable

The APL5501/2/3 has an active high enable function. Force EN high ($>1.6\text{V}$) enables the regulator, EN low ($<0.4\text{V}$) disables the regulator and enter the shutdown mode. In shutdown mode, the quiescent current can reduce below $1\mu\text{A}$. The EN pin cannot be floating, a floating EN pin may cause an indeterminate state on the output. If it is no use, connect to V_{IN} for normal operation.

Current Limit

The APL5501/2/3 has a current limit protection. The output voltage will drop close to zero volt, when load current reaches the limit, and then the load current will be limited at 150mA after output voltage is below 0.7V . When the load current back to the value where limiting started, the output voltage and current will return to normal value. When output is shorted to ground, the APL5501/2/3 will keep short circuit current at 150mA .

Thermal Protection

Thermal protection limits total power dissipation in the device. When the junction temperature exceeds $T_J=+150$, the thermal sensor generates a logic signal to turn off the pass transistor and allows IC to cool. When the IC's junction temperature is down by 10 , the thermal sensor will turn the pass transistor on again, resulting in a pulsed output during continuous thermal protection. Thermal protection is designed to protect the APL5501/2/3 in the event of fault conditions. For continuous operation, do not exceed the absolute maximum junction temperature of $T_J=+150$.

Operating Region and Power Dissipation

The thermal resistance of the case to circuit board, and the rate of air flow all control the APL5501/2/3's maximum power dissipation. The power dissipation across the device is $P_D = I_{OUT}(V_{IN}-V_{OUT})$ and the maximum power dissipation is:

$$P_{D_{MAX}} = (T_J - T_A) / (\theta_{JC} + \theta_{CA})$$

where $T_J - T_A$ is the temperature difference between the junction and ambient air, θ_{JC} is the thermal resistance of the package, and θ_{CA} is the thermal resistance through the printed circuit board, copper traces, and other materials to the ambient air.

The GND pin of the APL5501/3 provides an electrical connection to ground and channeling heat away. If power dissipation is large, connect the GND pin to ground using a large pad or ground plane, can improve the problem of over heat of IC.

Package Information

SOT-23-5

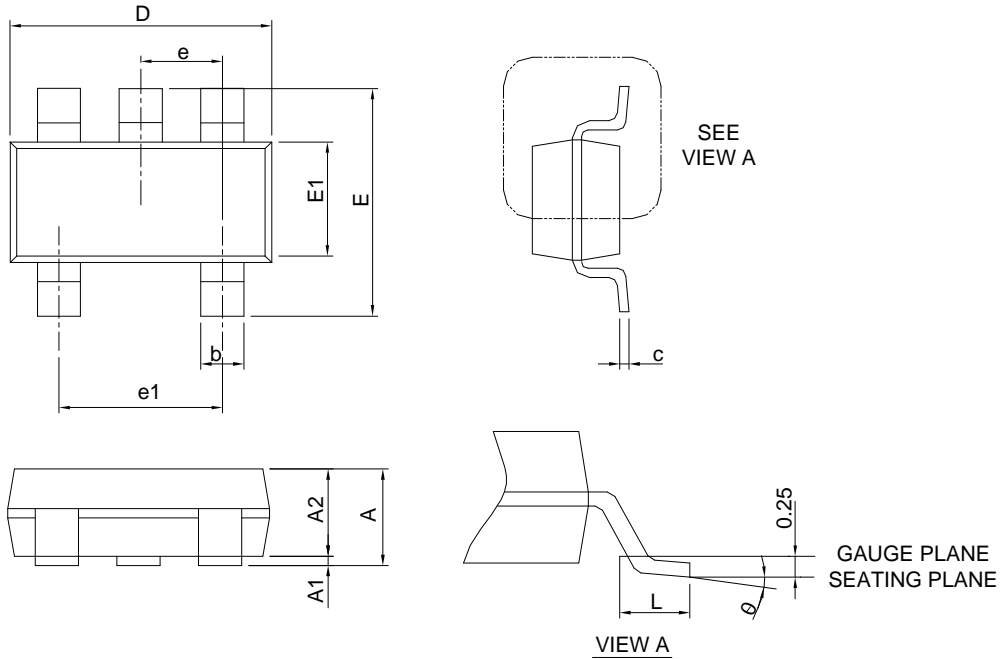

SYMBOL	SOT-23-5			
	MILLIMETERS		INCHES	
	MIN.	MAX.	MIN.	MAX.
A		1.45		0.057
A1	0.00	0.15	0.000	0.006
A2	0.90	1.30	0.035	0.051
b	0.30	0.50	0.012	0.020
c	0.08	0.22	0.003	0.009
D	2.70	3.10	0.016	0.122
E	2.60	3.00	0.102	0.118
E1	1.40	1.80	0.055	0.071
e	0.95 BSC		0.037 BSC	
e1	1.90 BSC		0.075 BSC	
L	0.30	0.60	0.012	0.024
θ	0°	8°	0°	8°

Note : 1. Follow JEDEC TO-178 AA.

2. Dimension D and E1 do not include mold flash, protrusions or gate burrs. Mold flash, protrusion or gate burrs shall not exceed 10 mil per side.

Package Information

SOP-8

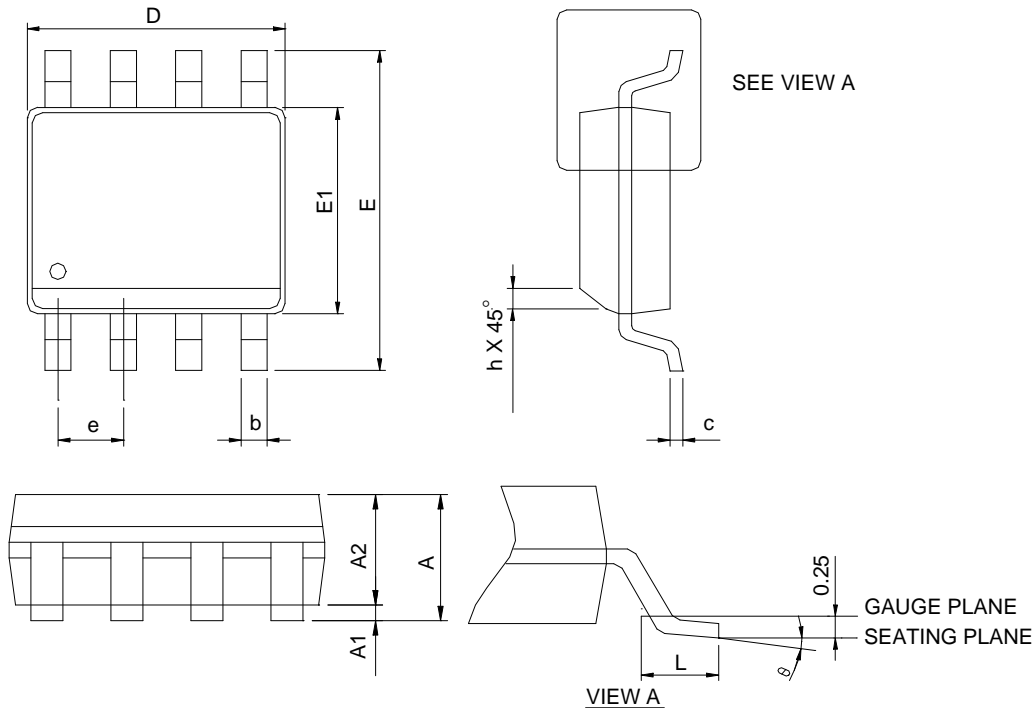

SYMBOL	SOP-8			
	MILLIMETERS		INCHES	
	MIN.	MAX.	MIN.	MAX.
A		1.75		0.069
A1	0.10	0.25	0.004	0.010
A2	1.25		0.049	
b	0.31	0.51	0.012	0.020
c	0.17	0.25	0.007	0.010
D	4.80	5.00	0.189	0.197
E	5.80	6.20	0.228	0.244
E1	3.80	4.00	0.150	0.157
e	1.27 BSC		0.050 BSC	
h	0.25	0.50	0.010	0.020
L	0.40	1.27	0.016	0.050
θ	0°	8°	0°	8°

- Note: 1. Follow JEDEC MS-012 AA.
 2. Dimension "D" does not include mold flash, protrusions or gate burrs. Mold flash, protrusion or gate burrs shall not exceed 6 mil per side.
 3. Dimension "E" does not include inter-lead flash or protrusions. Inter-lead flash and protrusions shall not exceed 10 mil per side.

Package Information

SOT-223

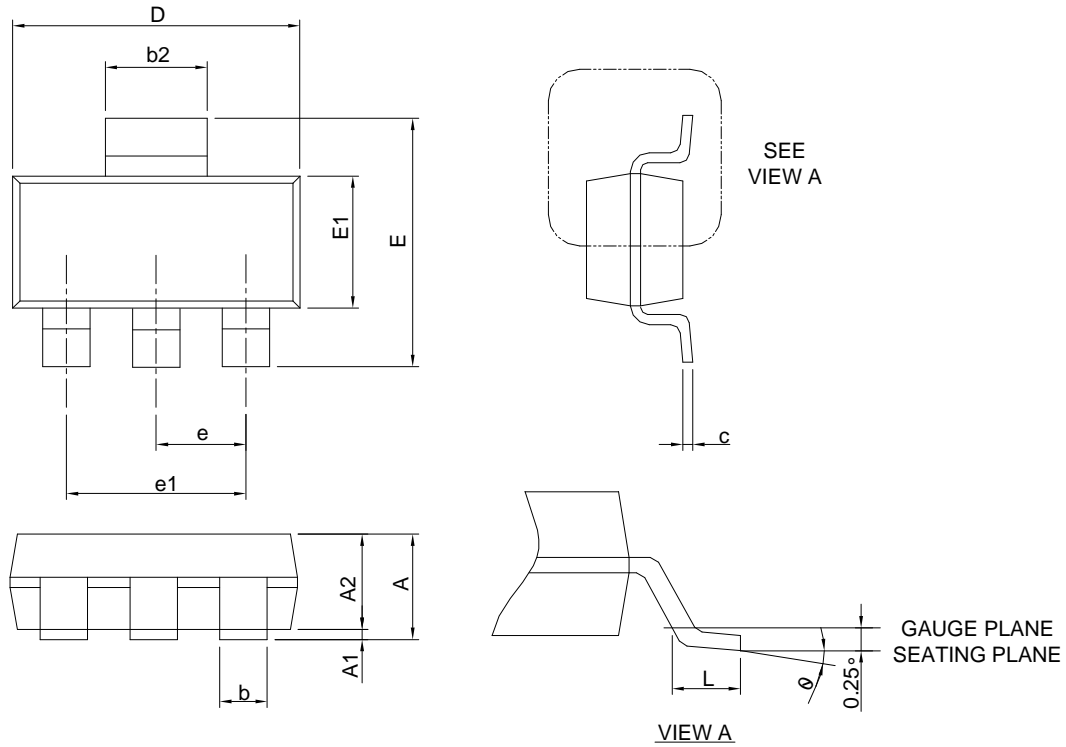

SYMBOL	SOT-223			
	MILLIMETERS		INCHES	
	MIN.	MAX.	MIN.	MAX.
A		1.80		0.071
A1	0.02	0.10	0.001	0.004
A2	1.50	1.70	0.059	0.067
b	0.66	0.84	0.026	0.033
b2	2.90	3.10	0.114	0.122
c	0.23	0.33	0.009	0.013
D	6.30	6.70	0.248	0.264
E	6.70	7.30	0.264	0.287
E1	3.30	3.70	0.130	0.146
e	2.30 BSC		0.091 BSC	
e1	4.60 BSC		0.181 BSC	
L	0.75		0.030	
θ	0°	10°	0°	10°

Note : 1. Follow from JEDEC TO-261 AA.

2. Dimension D and E1 are determined at the outermost extremes of the plastic exclusive of mold flash, tie bar burrs, gate burrs, and interlead flash, but including any mismatch between the top and bottom of the plastic body.

Package Information

SOT-89

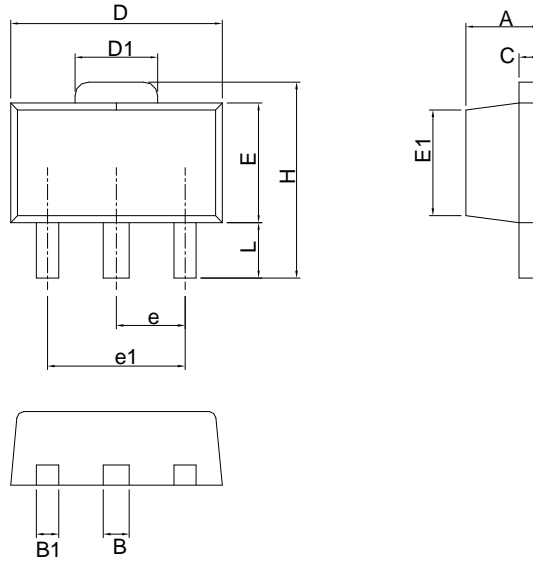

SYMBOL	SOT-89			
	MILLIMETERS		INCHES	
	MIN.	MAX.	MIN.	MAX.
A	1.40	1.60	0.055	0.063
B	0.44	0.56	0.017	0.022
B1	0.36	0.48	0.014	0.019
C	0.35	0.44	0.014	0.017
D	4.40	4.60	0.173	0.181
D1	1.62	1.83	0.064	0.072
E	2.29	2.60	0.090	0.102
E1	2.13	2.29	0.084	0.090
e	1.50 BSC		0.059 BSC	
e1	3.00 BSC		0.118 BSC	
H	3.94	4.25	0.155	0.167
L	0.89	1.20	0.035	0.047

Note : Follow JEDEC TO-243 AA.

Package Information

SOT-89-5

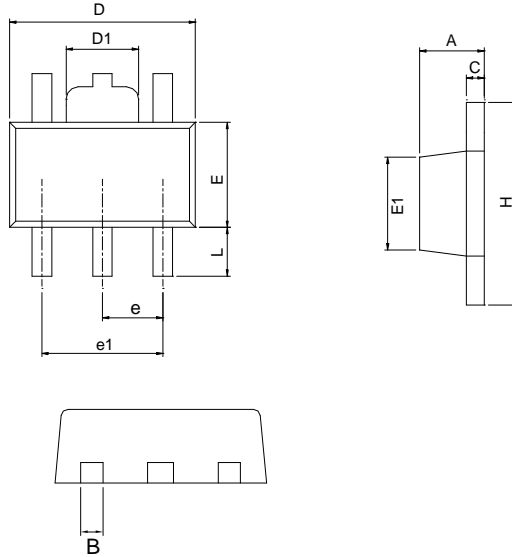

Symbol	SOT-89-5			
	MILLIMETERS		INCHES	
	MIN.	MAX.	MIN.	MAX.
A	1.40	1.60	0.055	0.063
B	0.36	0.56	0.014	0.022
C	0.35	0.44	0.014	0.017
D	4.40	4.60	0.173	0.181
D1	1.62	1.83	0.064	0.072
E	2.29	2.60	0.090	0.102
E1	2.13	2.29	0.084	0.090
e	1.50 BSC		0.059 BSC	
e1	3.00 BSC		0.118 BSC	
H	3.94	4.25	0.155	0.167
L	0.89	1.20	0.035	0.047

Package Information

TO-252

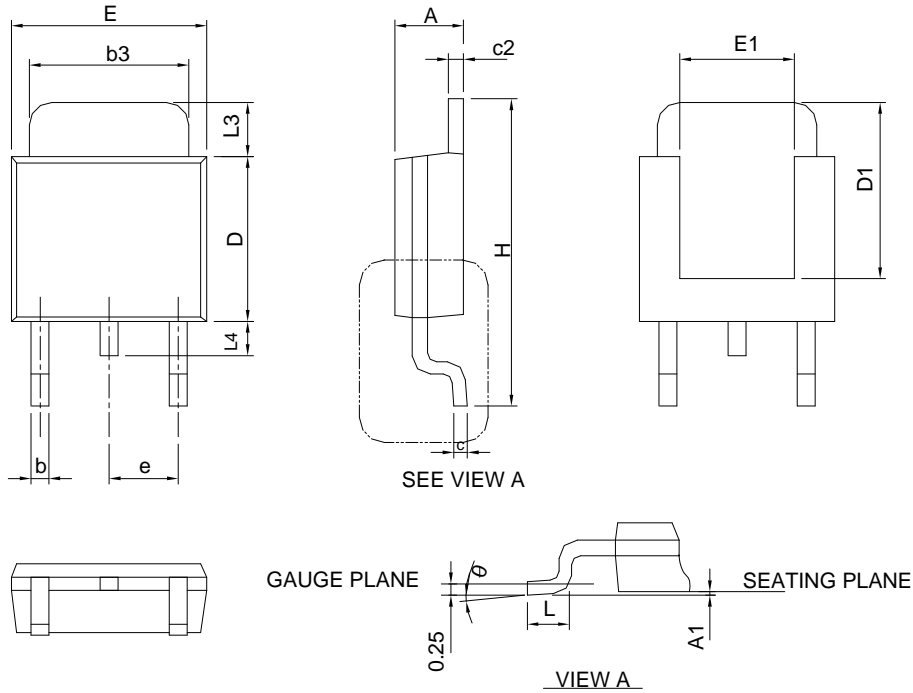

SYMBOL	TO-252			
	MILLIMETERS		INCHES	
	MIN.	MAX.	MIN.	MAX.
A	2.18	2.39	0.086	0.094
A1		0.13		0.005
b	0.50	0.89	0.020	0.035
b3	4.95	5.46	0.195	0.215
c	0.46	0.61	0.018	0.024
c2	0.46	0.89	0.018	0.035
D	5.33	6.22	0.210	0.245
D1	4.57	6.00	0.180	0.235
E	6.35	6.73	0.250	0.265
E1	3.81	6.00	0.150	0.235
e	2.29 BSC		0.090 BSC	
H	9.40	10.41	0.370	0.410
L	0.90	1.78	0.035	0.070
L3	0.89	2.03	0.035	0.080
L4		1.02		0.040
θ	0°	8°	0°	8°

Note : Follow JEDEC TO-252 .

Package Information

TO-252-5

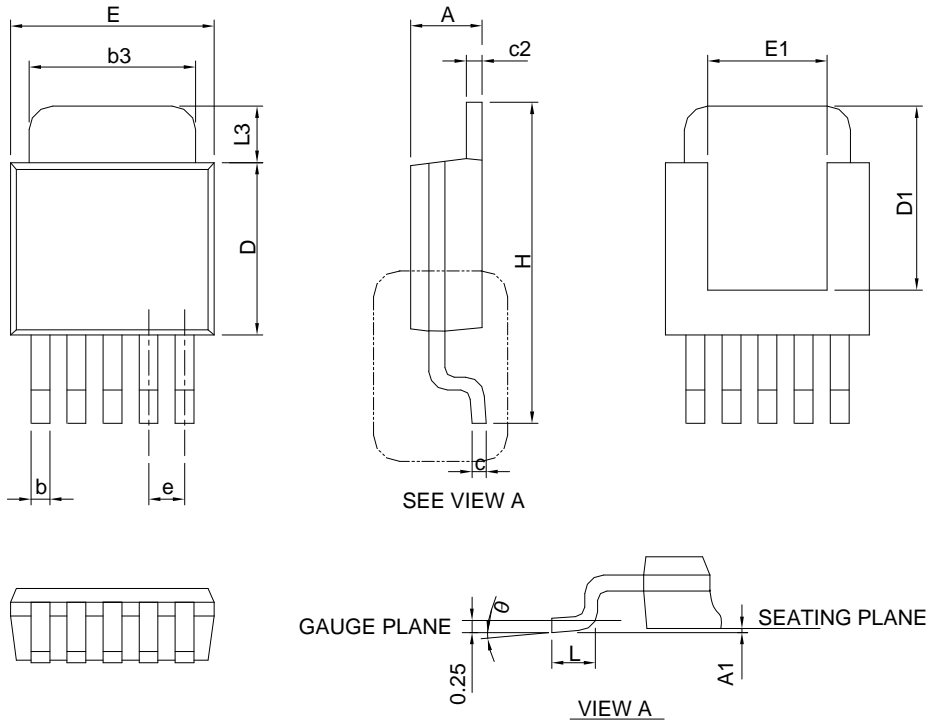

SYMBOL	TO-252-5			
	MILLIMETERS		INCHES	
	MIN.	MAX.	MIN.	MAX.
A	2.18	2.39	0.086	0.094
A1		0.13		0.005
b	0.50	0.89	0.020	0.035
b3	4.32	5.46	0.170	0.215
c	0.46	0.61	0.018	0.024
c2	0.46	0.89	0.018	0.035
D	5.33	6.22	0.210	0.245
D1	4.57	6.00	0.180	0.236
E	6.35	6.73	0.250	0.265
E1	3.81	6.00	0.150	0.236
e	1.27 BSC		0.050 BSC	
H	9.40	10.41	0.370	0.410
L	1.40	1.78	0.055	0.070
L3	0.89	2.03	0.035	0.080
θ	0°	8°	0°	8°

Carrier Tape & Reel Dimensions

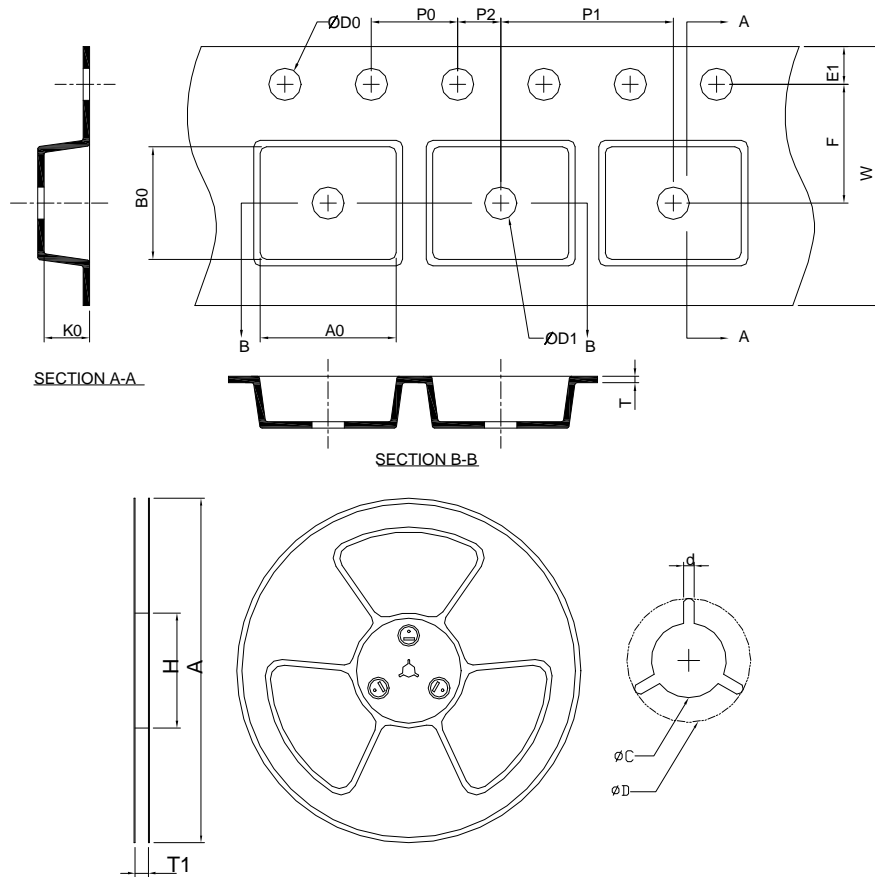

Application	A	H	T1	C	d	D	W	E1	F
SOP-8	330.0 ± 2.00	50 MIN.	12.4+2.00 -0.00	13.0+0.50 -0.20	1.5 MIN.	20.2 MIN.	12.0 ±0.30	1.75 ±0.10	5.5 ±0.05
	P0	P1	P2	D0	D1	T	A0	B0	K0
	4.0 ±0.10	8.0 ±0.10	2.0 ±0.05	1.5+0.10 -0.00	1.5 MIN.	0.6+0.00 -0.40	6.40 ±0.20	5.20 ±0.20	2.10 ±0.20
Application	A	H	T1	C	d	D	W	E1	F
SOT-89	178.0 ± 2.00	50 MIN.	8.4+2.00 -0.00	13.0+0.50 -0.20	1.5 MIN.	20.2 MIN.	12.0 ±0.30	1.75 ±0.10	5.50 ±0.05
	P0	P1	P2	D0	D1	T	A0	B0	K0
	4.0 ±0.10	8.0 ±0.10	2.0 ±0.10	1.5+0.10 -0.00	1.5 MIN.	0.6+0.00 -0.40	4.80 ±0.20	4.50 ±0.20	1.80 ±0.20
Application	A	H	T1	C	d	D	W	E1	F
SOT-23-5	178.0 ± 2.00	50 MIN.	8.4+2.00 -0.00	13.0+0.50 -0.20	1.5 MIN.	20.2 MIN.	8.0 ±0.30	1.75 ±0.10	3.5 ±0.05
	P0	P1	P2	D0	D1	T	A0	B0	K0
	4.0 ±0.10	4.0 ±0.10	2.0 ±0.10	1.5+0.10 -0.00	1.5 MIN.	0.6+0.00 -0.40	3.20 ±0.20	3.10 ±0.20	1.50 ±0.20
Application	A	H	T1	C	d	D	W	E1	F
TO-252	330.0 ± 2.00	50 MIN.	16.4+2.00 -0.00	13.0+0.50 -0.20	1.5 MIN.	20.2 MIN.	16.0 ±0.30	1.75 ±0.10	7.50 ±0.05
	P0	P1	P2	D0	D1	T	A0	B0	K0
	4.0 ±0.10	8.0 ±0.10	2.0 ±0.05	1.5+0.10 -0.00	1.5 MIN.	0.6+0.00 -0.40	6.80 ±0.20	10.40 ± 0.20	2.50 ±0.20

(mm)

Devices Per Unit

Package Type	Unit	Quantity
SOP-8	Tape & Reel	2500
SOT-89		1000
TO-23-5		3000
TO-252		2500

Reflow Condition (IR/Convection or VPR Reflow)

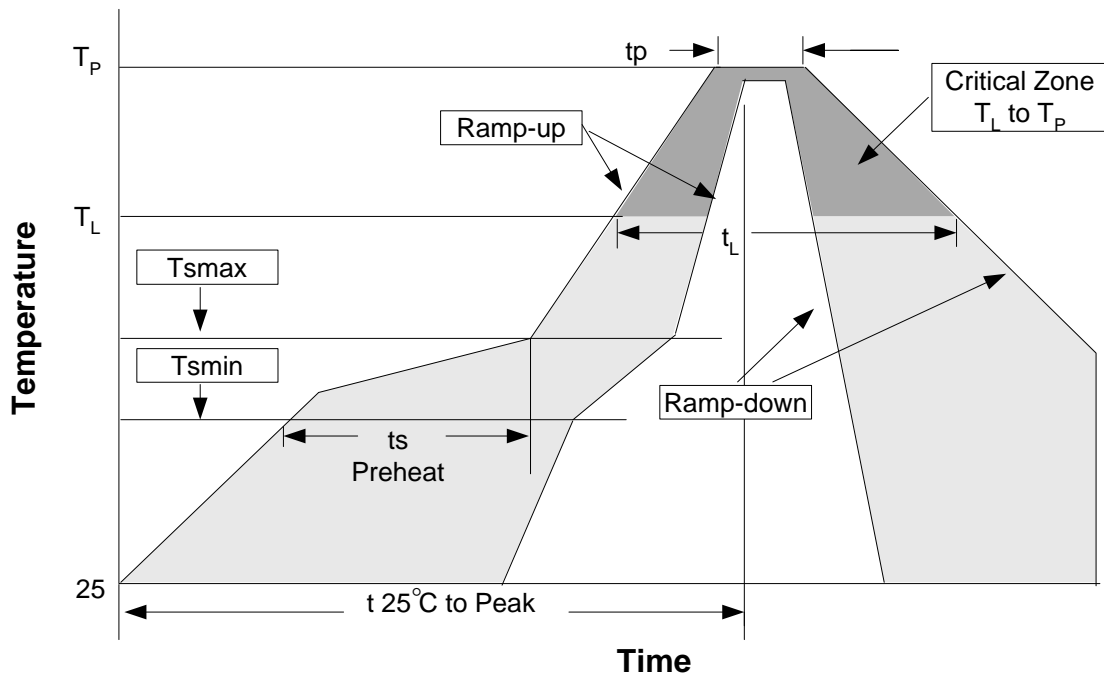

Reliability Test Program

Test item	Method	Description
SOLDERABILITY	MIL-STD-883D-2003	245°C, 5 sec
HOLT	MIL-STD-883D-1005.7	1000 Hrs Bias @ 125°C
PCT	JESD-22-B, A102	168 Hrs, 100%RH, 121°C
TST	MIL-STD-883D-1011.9	-65°C~150°C, 200 Cycles
ESD	MIL-STD-883D-3015.7	VHBM > 2KV, VMM > 200V
Latch-Up	JESD 78	10ms, $I_{tr} > 100mA$

Classification Reflow Profiles

Profile Feature	Sn-Pb Eutectic Assembly	Pb-Free Assembly
Average ramp-up rate (T _L to T _P)	3°C/second max.	3°C/second max.
Preheat - Temperature Min (T _{sm}) - Temperature Max (T _{sm}) - Time (min to max) (t _s)	100°C 150°C 60-120 seconds	150°C 200°C 60-180 seconds
Time maintained above: - Temperature (T _L) - Time (t _L)	183°C 60-150 seconds	217°C 60-150 seconds
Peak/Classification Temperature (T _p)	See table 1	See table 2
Time within 5°C of actual Peak Temperature (t _p)	10-30 seconds	20-40 seconds
Ramp-down Rate	6°C/second max.	6°C/second max.
Time 25°C to Peak Temperature	6 minutes max.	8 minutes max.

Note: All temperatures refer to topside of the package. Measured on the body surface.

Table 1. SnPb Eutectic Process – Package Peak Reflow Temperatures

Package Thickness	Volume mm ³ <350	Volume mm ³ ≥350
<2.5 mm	240 +0/-5°C	225 +0/-5°C
≥2.5 mm	225 +0/-5°C	225 +0/-5°C

Table 2. Pb-free Process – Package Classification Reflow Temperatures

Package Thickness	Volume mm ³ <350	Volume mm ³ 350-2000	Volume mm ³ >2000
<1.6 mm	260 +0°C*	260 +0°C*	260 +0°C*
1.6 mm – 2.5 mm	260 +0°C*	250 +0°C*	245 +0°C*
≥2.5 mm	250 +0°C*	245 +0°C*	245 +0°C*

*Tolerance: The device manufacturer/supplier **shall** assure process compatibility up to and including the stated classification temperature (this means Peak reflow temperature +0°C. For example 260°C+0°C) at the rated MSL level.

Customer Service

Anpec Electronics Corp.

Head Office :

No.6, Dusing 1st Road, SBIP,
Hsin-Chu, Taiwan
Tel : 886-3-5642000
Fax : 886-3-5642050

Taipei Branch :

2F, No. 11, Lane 218, Sec 2 Jhongsing Rd.,
Sindian City, Taipei County 23146, Taiwan
Tel : 886-2-2910-3838
Fax : 886-2-2917-3838