



MM54HC76/MM74HC76 Dual J-K Flip-Flops with Preset and Clear

General Description

These high speed (30 MHz minimum) J-K Flip-Flops utilize advanced silicon-gate CMOS technology to achieve, the low power consumption and high noise immunity of standard CMOS integrated circuits, along with the ability to drive 10 LS-TTL loads.

Each flip-flop has independent J, K, PRESET, CLEAR, and CLOCK inputs and Q and \bar{Q} outputs. These devices are edge sensitive to the clock input and change state on the negative going transition of the clock pulse. Clear and preset are independent of the clock and accomplished by a low logic level on the corresponding input.

The 54HC/74HC logic family is functionally as well as pin-out compatible with the standard 54LS/74LS logic family. All inputs are protected from damage due to static discharge by internal diode clamps to V_{CC} and ground.

Features

- Typical propagation delay: 16 ns
- Wide operating voltage range
- Low input current: 1 μ A maximum
- Low quiescent current: 40 μ A maximum (74HC Series)
- High output drive: 10 LS-TTL loads

Connection and Logic Diagrams

Truth Table

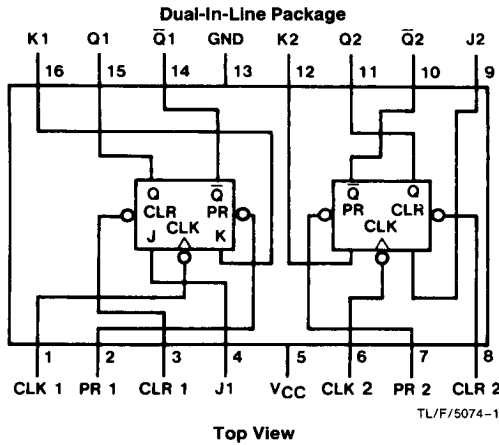

Inputs					Outputs	
PR	CLR	CLK	J	L	Q	\bar{Q}
L	H	X	X	X	H	L
H	L	X	X	X	L	H
L	L	X	X	X	L*	L*
H	H	↓	L	L	Q0	$\bar{Q}0$
H	H	↓	H	L	H	L
H	H	↓	L	H	L	H
H	H	↓	H	H	TOGGLE	TOGGLE
H	H	H	X	X	Q0	$\bar{Q}0$

*This is an unstable condition, and is not guaranteed

Order Number MM54HC76* or MM74HC76*

*Please look into Section 8, Appendix D for availability of various package types.

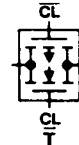
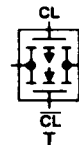
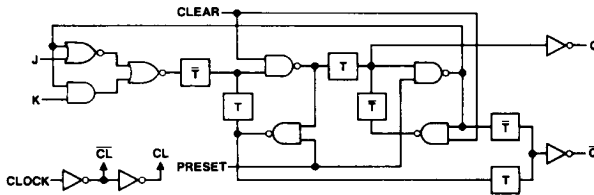

TL/F/5074-3

Absolute Maximum Ratings (Notes 1 & 2)

If Military/Aerospace specified devices are required, contact the National Semiconductor Sales Office/Distributors for availability and specifications.

Supply Voltage (V_{CC})	- 0.5 to + 7.0V
DC Input Voltage (V_{IN})	- 1.5 to V_{CC} + 1.5V
DC Output Voltage (V_{OUT})	- 0.5 to V_{CC} + 0.5V
Clamp Diode Current (I_{IK}, I_{OK})	± 20 mA
DC Output Current, per pin (I_{OUT})	± 25 mA
DC V_{CC} or GND Current, per pin (I_{CC})	± 50 mA
Storage Temperature Range (T_{STG})	- 65°C to + 150°C
Power Dissipation (P_D) (Note 3)	600 mW
S.O. Package only	500 mW
Lead Temp. (T_L) (Soldering 10 seconds)	260°C

Operating Conditions

	Min	Max	Units
Supply Voltage (V_{CC})	2	6	V
DC Input or Output Voltage (V_{IN}, V_{OUT})	0	V_{CC}	V
Operating Temp. Range (T_A)			
MM74HC	- 40	+ 85	°C
MM54HC	- 55	+ 125	°C
Input Rise or Fall Times (t_r, t_f)			
$V_{CC} = 2.0V$		1000	ns
$V_{CC} = 4.5V$		500	ns
$V_{CC} = 6.0V$		400	ns

DC Electrical Characteristics (Note 4)

Symbol	Parameter	Conditions	V_{CC}	$T_A = 25^\circ C$		74HC $T_A = -40 \text{ to } 85^\circ C$		54HC $T_A = -55 \text{ to } 125^\circ C$		Units	
				Typ	Guaranteed Limits						
V_{IH}	Minimum High Level Input Voltage		2.0V		1.5	1.5	1.5		V		
			4.5V		3.15	3.15	3.15		V		
			6.0V		4.2	4.2	4.2		V		
V_{IL}	Maximum Low Level Input Voltage**		2.0V		0.5	0.5	0.5		V		
			4.5V		1.35	1.35	1.35		V		
			6.0V		1.8	1.8	1.8		V		
V_{OH}	Minimum High Level Output Voltage	$V_{IN} = V_{IH}$ or V_{IL} $ I_{OUT} \leq 20 \mu A$	2.0V	2.0	1.9	1.9	1.9		V		
			4.5V	4.5	4.4	4.4	4.4		V		
			6.0V	6.0	5.9	5.9	5.9		V		
		$V_{IN} = V_{IH}$ or V_{IL} $ I_{OUT} \leq 4.0 \text{ mA}$ $ I_{OUT} \leq 5.2 \text{ mA}$	4.5V	4.2	3.98	3.84	3.7		V		
			6.0V	5.7	5.48	5.34	5.2		V		
V_{OL}	Maximum Low Level Output Voltage	$V_{IN} = V_{IH}$ or V_{IL} $ I_{OUT} \leq 20 \mu A$	2.0V	0	0.1	0.1	0.1		V		
			4.5V	0	0.1	0.1	0.1		V		
			6.0V	0	0.1	0.1	0.1		V		
		$V_{IN} = V_{IH}$ or V_{IL} $ I_{OUT} \leq 4.0 \text{ mA}$ $ I_{OUT} \leq 5.2 \text{ mA}$	4.5V	0.2	0.26	0.33	0.4		V		
			6.0V	0.2	0.26	0.33	0.4		V		
I_{IN}	Maximum Input Current	$V_{IN} = V_{CC}$ or GND	6.0V		± 0.1	± 1.0	± 1.0	μA			
I_{CC}	Maximum Quiescent Supply Current	$V_{IN} = V_{CC}$ or GND $I_{OUT} = 0 \mu A$	6.0V		4	40	80	μA			

Note 1: Absolute Maximum Ratings are those values beyond which damage to the device may occur.

Note 2: Unless otherwise specified all voltages are referenced to ground.

Note 3: Power Dissipation temperature derating — plastic "N" package: - 12 mW/°C from 65°C to 85°C; ceramic "J" package: - 12 mW/°C from 100°C to 125°C.

Note 4: For a power supply of $5V \pm 10\%$ the worst case output voltages (V_{OH} , and V_{OL}) occur for HC at 4.5V. Thus the 4.5V values should be used when designing with this supply. Worst case V_{IH} and V_{IL} occur at $V_{CC} = 5.5V$ and 4.5V respectively. (The V_{IH} value at 5.5V is 3.85V.) The worst case leakage current (I_{IN} , I_{CC} , and I_{O2}) occur for CMOS at the higher voltage and so the 6.0V values should be used.

** V_{IL} limits are currently tested at 20% of V_{CC} . The above V_{IL} specification (30% of V_{CC}) will be implemented no later than Q1, CY'89.

AC Electrical Characteristics $V_{CC}=5V$, $T_A=25^\circ C$, $C_L=15\text{ pF}$, $t_r=t_f=6\text{ ns}$

Symbol	Parameter	Conditions	Typ	Guaranteed Limit	Units
f_{MAX}	Maximum Operating Frequency		50	30	MHz
t_{PHL} , t_{PLH}	Maximum Propagation Delay Clock to Q or \bar{Q}		16	21	ns
t_{PHL} , t_{PLH}	Maximum Propagation Delay Clear to Q or \bar{Q}		21	26	ns
t_{PHL} , t_{PLH}	Maximum Propagation Delay Preset to Q or \bar{Q}		23	28	ns
t_{REM}	Minimum Removal Time		10	20	ns
t_s	Minimum Setup Time J or K to Clock		14	20	ns
t_H	Minimum Hold Time J or K to Clock		-3	0	ns
t_W	Minimum Pulse Width Preset, Clear or Clock		10	16	ns

AC Electrical Characteristics $C_L=50\text{ pF}$, $t_r=t_f=6\text{ ns}$ (unless otherwise specified)

Symbol	Parameter	Conditions	V_{CC}	$T_A=25^\circ C$		74HC	54HC	Units
						$T_A=-40\text{ to }85^\circ C$	$T_A=-55\text{ to }125^\circ C$	
				Typ	Guaranteed Limits			
f_{MAX}	Maximum Operating Frequency		2.0V	9	5	4	3	MHz
			4.5V	45	27	21	18	MHz
			6.0V	53	31	24	20	MHz
t_{PHL} , t_{PLH}	Maximum Propagation Delay Clock to Q or \bar{Q}		2.0V	100	126	160	183	ns
			4.5V	20	25	31	37	ns
			6.0V	17	21	27	32	ns
t_{PHL} , t_{PLH}	Maximum Propagation Delay Clear to Q or \bar{Q}		2.0V	126	155	191	250	ns
			4.5V	25	31	39	47	ns
			6.0V	21	26	33	40	ns
t_{PHL} , t_{PLH}	Maximum Propagation Delay, Preset to Q or \bar{Q}		2.0V	137	165	210	240	ns
			4.5V	27	33	41	50	ns
			6.0V	23	28	35	40	ns
t_{REM}	Minimum Removal Time Preset or Clear to Clock		2.0V	55	100	125	150	ns
			4.5V	11	20	25	30	ns
			6.0V	9	17	21	25	ns
t_s	Minimum Setup Time J or K to Clock		2.0V	77	100	125	150	ns
			4.5V	15	20	25	30	ns
			6.0V	13	17	21	25	ns
t_H	Minimum Hold Time J or K from Clock		2.0V	-3	0	0	0	ns
			4.5V	-3	0	0	0	ns
			6.0V	-3	0	0	0	ns
t_W	Minimum, Pulse Width, Preset, Clear or Clock		2.0V	55	80	100	120	ns
			4.5V	11	16	20	24	ns
			6.0V	9	14	18	21	ns
t_{TLH} , t_{THL}	Maximum Output Rise and Fall Time		2.0V	30	75	95	110	ns
			4.5V	8	15	19	22	ns
			6.0V	7	13	16	19	ns
t_r , t_f	Maximum Input Rise and Fall Time		2.0V		1000	1000	1000	ns
			4.5V		500	500	500	ns
			6.0V		400	400	400	ns
C_{PD}	Power Dissipation Capacitance (Note 5)	(per flip-flop)		80				pF
C_{IN}	Maximum Input Capacitance			5	10	10	10	pF

Note 5: C_{PD} determines the no load dynamic power consumption, $P_D = C_{PD} V_{CC}^2 f + I_{CC} V_{CC}$, and the no load dynamic current consumption, $I_S = C_{PD} V_{CC} f + I_{CC}$.

Typical Applications

N Bit Presettable Ripple Counter with Enable and Reset

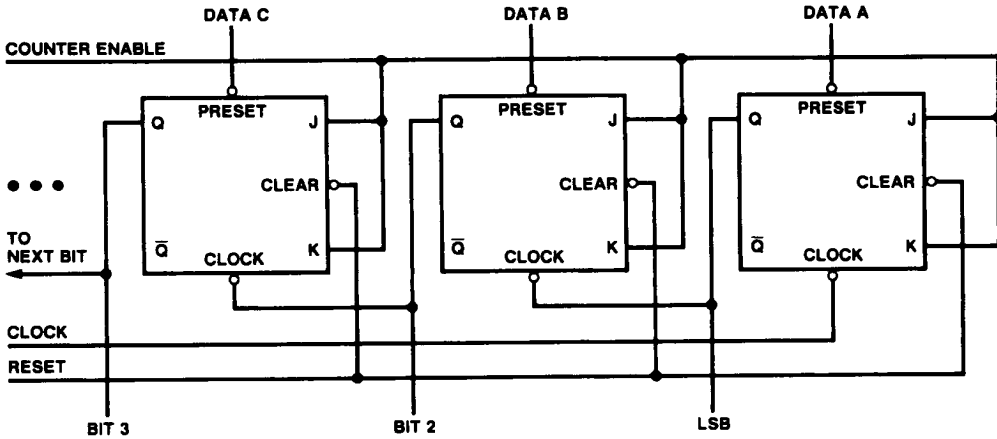

TL/F/5074-4

N Bit Parallel Load/Serial Load Shift Register with Clear

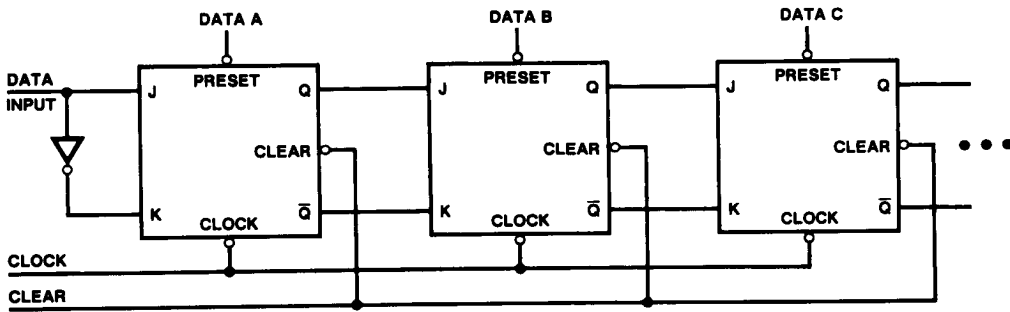

TL/F/5074-5