

# TYPES SN54LS640 THRU SN54LS645, SN74LS640 THRU SN74LS645 OCTAL BUS TRANSCEIVERS

D2420, APRIL 1979 - REVISED DECEMBER 1983

- **SN74LS64X-1 Versions Rated at  $I_{OL}$  of 48 mA**
- **Bi-directional Bus Transceivers in High-Density 20-Pin Packages**
- **Hysteresis at Bus Inputs Improves Noise Margins**
- **Choice of True or Inverting Logic**
- **Choice of 3-State or Open-Collector Outputs**

DEVICE	OUTPUT	LOGIC
'LS640	3-State	Inverting
'LS641	Open-Collector	True
'LS642	Open-Collector	Inverting
'LS643	3-State	True and inverting
'LS644	Open-Collector	True and inverting
'LS645	3-State	True

## description

These octal bus transceivers are designed for asynchronous two-way communication between data buses. The devices transmit data from the A bus to the B bus or from the B bus to the A bus depending upon the level at the direction control (DIR) input. The enable input ( $\bar{G}$ ) can be used to disable the device so the buses are effectively isolated.

The -1 versions of the SN74LS640 thru SN74LS645 are identical to the standard versions except that the recommended maximum  $I_{OL}$  is increased to 48 milliamperes. There are no -1 versions of the SN54LS640 thru SN54LS645.

The SN54LS640 thru SN54LS645 are characterized for operation over the full military temperature range of -55°C to 125°C. The SN74LS640 thru SN74LS645 are characterized for operation from 0°C to 70°C.

SN54LS' ... J PACKAGE  
SN74LS' ... DW, J OR N PACKAGE  
(TOP VIEW)

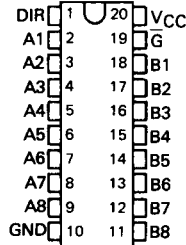

SN54LS' ... FK PACKAGE  
SN74LS' ... FN PACKAGE  
(TOP VIEW)

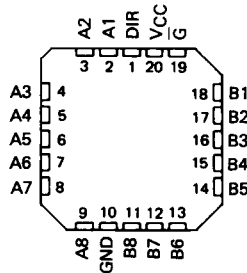

FUNCTION TABLE

CONTROL INPUTS		OPERATION		
$\bar{G}$	DIR	'LS640 'LS642	'LS641 'LS645	'LS643 'LS644
L	L	B data to A bus	B data to A bus	B data to A bus
L	H	A data to B bus	A data to B bus	$\bar{A}$ data to B bus
H	X	Isolation	Isolation	Isolation

H = high level, L = low level, X = irrelevant

## PRODUCTION DATA

This document contains information current as of publication date. Products conform to specifications per the terms of Texas Instruments standard warranty. Production processing does not necessarily include testing of all parameters.

**TEXAS  
INSTRUMENTS**

POST OFFICE BOX 225012 • DALLAS, TEXAS 75265

3-1233

# TYPES SN54LS640 THRU SN54LS645, SN74LS640 THRU SN74LS645 OCTAL BUS TRANSCEIVERS

logic symbols

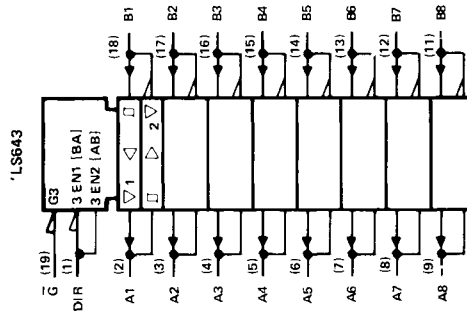
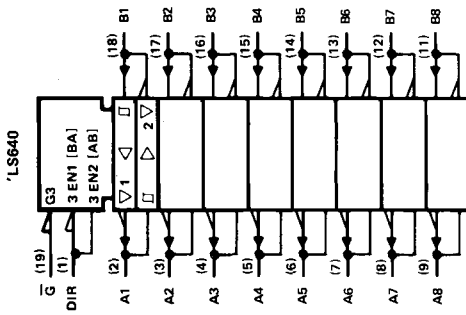
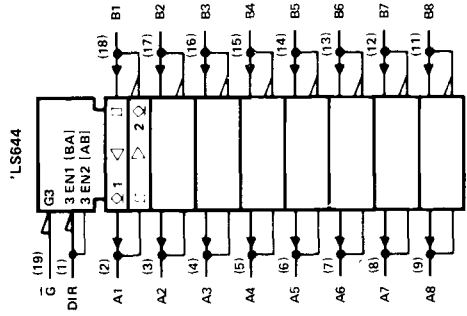
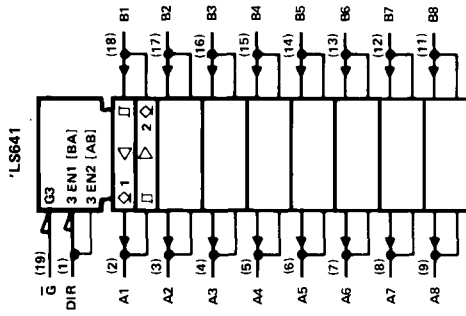
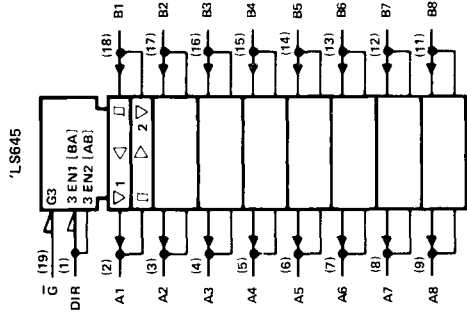
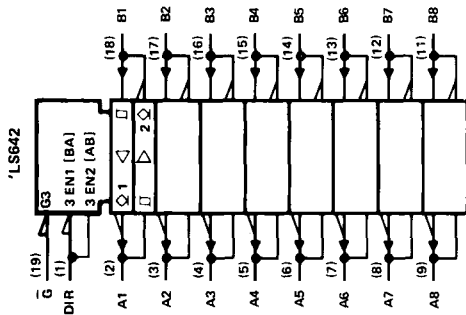

Pin numbers shown on logic notation are for DW, J or N packages.

**3** TTL DEVICES

TYPES SN54LS640 THRU SN54LS645,  
SN74LS640 THRU SN74LS645  
OCTAL BUS TRANSCEIVERS

logic diagrams

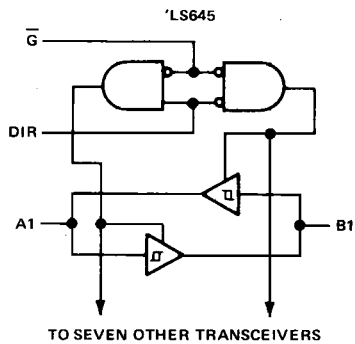
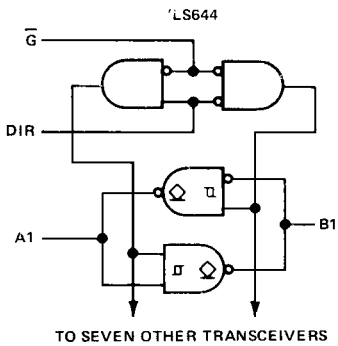
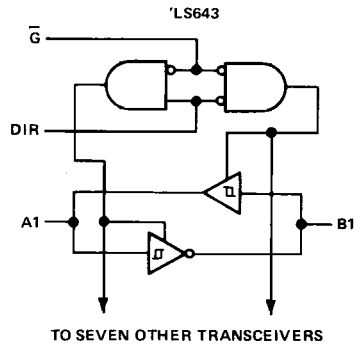
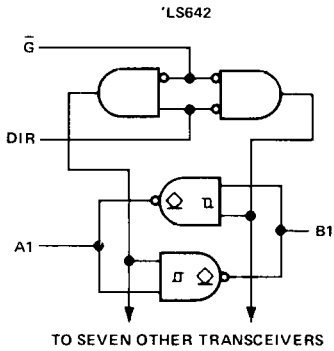
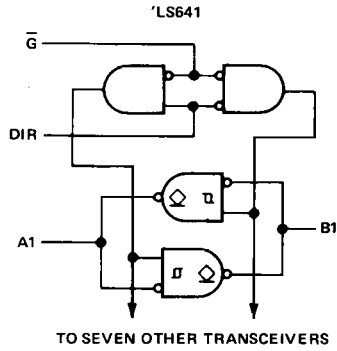
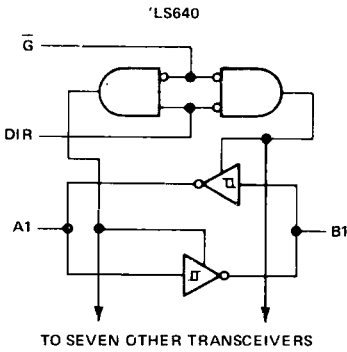

**TYPES SN54LS640, SN54LS643, SN54LS645,  
SN74LS640, SN74LS643, SN74LS645  
OCTAL BUS TRANSCEIVERS WITH 3-STATE OUTPUTS**

**absolute maximum ratings over operating free-air temperature range (unless otherwise noted)**

Supply voltage, $V_{CC}$ (see Note 1) .....	7 V
Input voltage: All inputs .....	7 V
I/O ports .....	5.5 V
Operating free-air temperature range: SN54LS640, SN54LS643, SN54LS645 .....	-55°C to 125°C
SN74LS640, SN74LS643, SN74LS645 .....	0°C to 70°C
Storage temperature range .....	-65°C to 150°C

NOTE 1: Voltage values are with respect to network ground terminal.

**recommended operating conditions**

PARAMETER	SN54LS640 SN54LS643 SN54LS645			SN74LS640 SN74LS643 SN74LS645			UNIT	
	MIN	NOM	MAX	MIN	NOM	MAX		
$V_{CC}$ Supply voltage	4.5	5	5.5	4.75	5	5.25	V	
$V_{IH}$ High-level input voltage	2			2			V	
$V_{IL}$ Low-level input voltage	0.5			0.6			V	
$I_{OH}$ High-level output current	-12			-15			mA	
$I_{OL}$ Low-level output current	12			24			mA	
				48§				
$T_A$ Operating free-air temperature	-55			0			70	°C

§ The 48 mA limit applies for the SN74LS640-1, SN74LS643-1, and SN74LS645-1 only.

**electrical characteristics over recommended operating free-air temperature range (unless otherwise noted)**

PARAMETER	TEST CONDITIONS †	SN54LS640 SN54LS643 SN54LS645			SN74LS640 SN74LS643 SN74LS645			UNIT
		MIN	TYP‡	MAX	MIN	TYP‡	MAX	
$V_{IK}$	$V_{CC} = \text{MIN}, I_I = -18 \text{ mA}$	-1.5			-1.5			V
Hysteresis ( $V_{T+} - V_{T-}$ )	$V_{CC} = \text{MIN},$ A or B input	0.1	0.4		0.2	0.4		V
$V_{OH}$	$V_{CC} = \text{MIN}, V_{IH} = 2 \text{ V},$ $V_{IL} = \text{MAX}$	$I_{OH} = -3 \text{ mA}$ 2.4 3.4			$I_{OH} = \text{MAX}$ 2 2			
$V_{OL}$	$V_{CC} = \text{MIN}, V_{IH} = 2 \text{ V},$ $V_{IL} = \text{MAX}$	$I_{OL} = 12 \text{ mA}$ 0.25 0.4			$I_{OL} = 24 \text{ mA}$ 0.35 0.5			V
		$I_{OL} = 48 \text{ mA} \uparrow$			0.4 0.5			
$I_{OZH}$	$V_{CC} = \text{MAX}, \bar{G}$ at 2 V, $V_O = 2.7 \text{ V}$	20			20			$\mu\text{A}$
$I_{OZL}$	$V_{CC} = \text{MAX}, \bar{G}$ at 2 V, $V_O = 0.4 \text{ V}$	-0.4			-0.4			mA
$I_I$	$V_{CC} = \text{MAX}$	$V_I = 5.5 \text{ V}$		0.1		0.1		mA
		$V_I = 7 \text{ V}$		0.1		0.1		
$I_{IH}$	$V_{CC} = \text{MAX}, V_{IH} = 2.7 \text{ V}$	20			20			$\mu\text{A}$
$I_{IL}$	$V_{CC} = \text{MAX}, V_{IL} = 0.4 \text{ V}$	-0.4			-0.4			mA
$I_{OS} \S$	$V_{CC} = \text{MAX}$	-40	-225		-40	-225		mA
$I_{CC}$	Outputs high	48 70		48 70				mA
	Outputs low	62 90		62 90				
	Outputs at Hi-Z	64 95		64 95				

† For conditions shown as MIN or MAX, use the appropriate value specified under recommended operating conditions.

‡ All typical values are at  $V_{CC} = 5 \text{ V}, T_A = 25^\circ\text{C}$ .

§ Not more than one output should be shorted at a time, and duration of the short-circuit should not exceed one second.

¶ The 48 mA condition applies for the SN74LS640-1, SN74LS643-1, and SN74LS645-1 only.

**3 TTL DEVICES**

**TYPES SN54LS640, SN54LS643, SN54LS645,  
SN74LS640, SN74LS643, SN74LS645  
OCTAL BUS TRANSCEIVERS WITH 3-STATE OUTPUTS**

switching characteristics at  $V_{CC} = 5\text{ V}$ ,  $T_A = 25^\circ\text{C}$

PARAMETER	FROM (INPUT)	TO (OUTPUT)	TEST CONDITIONS	'LS640, 'LS640-1			'LS643, 'LS643-1			'LS645, 'LS645-1			UNIT
				MIN	TYP	MAX	MIN	TYP	MAX	MIN	TYP	MAX	
Propagation delay time, low-to-high-level output t <sub>PLH</sub>	A	B	C <sub>L</sub> = 45 pF, R <sub>L</sub> = 667 Ω, See Note 2	6	10	6	10	8	15	8	15	ns	
	B	A		6	10	8	15	8	15	8	15	ns	
Propagation delay time, high-to-low-level output t <sub>PHL</sub>	A	B		8	15	9	15	11	15	11	15	ns	
	B	A		8	15	11	15	11	15	11	15	ns	
tpZL Output enable time to low level	G	A		31	40	32	45	31	40	31	40	ns	
tpZH Output enable time to high level	G	A		31	40	32	45	31	40	31	40	ns	
tpLZ Output disable time from low level	G	A	23	40	27	40	26	40	23	40	ns		
tpHZ Output disable time from high level	G	B	23	40	23	40	26	40	23	40	ns		
tpLZ Output disable time from low level	G	A	15	25	15	25	15	25	15	25	ns		
tpHZ Output disable time from high level	G	B	15	25	15	25	15	25	15	25	ns		
tpLZ Output disable time from low level	G	A	15	25	15	25	15	25	15	25	ns		
tpHZ Output disable time from high level	G	B	15	25	15	25	15	25	15	25	ns		

NOTE 2: See General Information Section for load circuits and voltage waveforms.

**schematics of inputs and outputs**

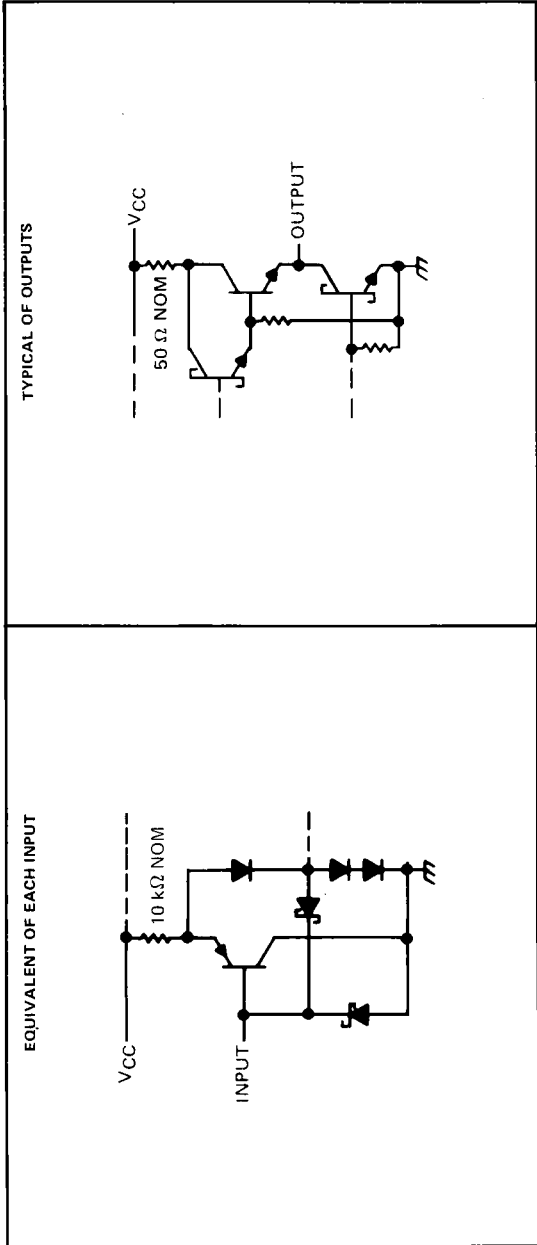

**TYPES SN54LS640, SN54LS643, SN54LS645,  
SN74LS640, SN74LS643, SN74LS645  
OCTAL BUS TRANSCEIVERS WITH 3-STATE OUTPUTS**

**TYPICAL CHARACTERISTICS**

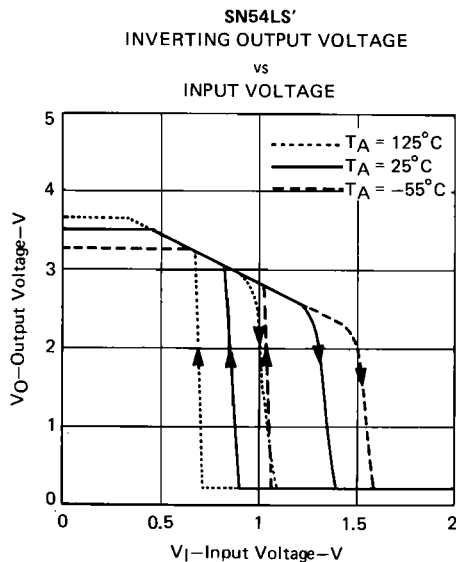

**FIGURE 1**

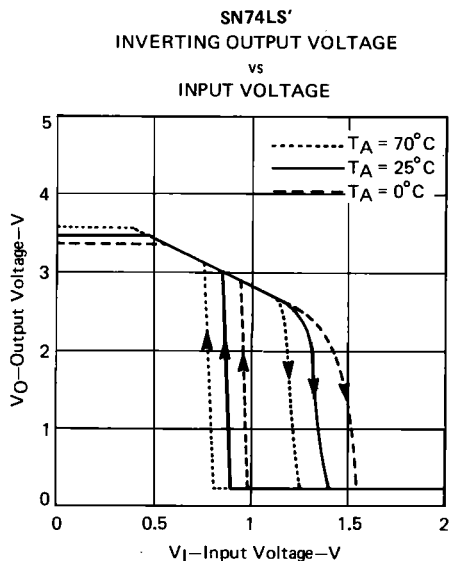

**FIGURE 2**

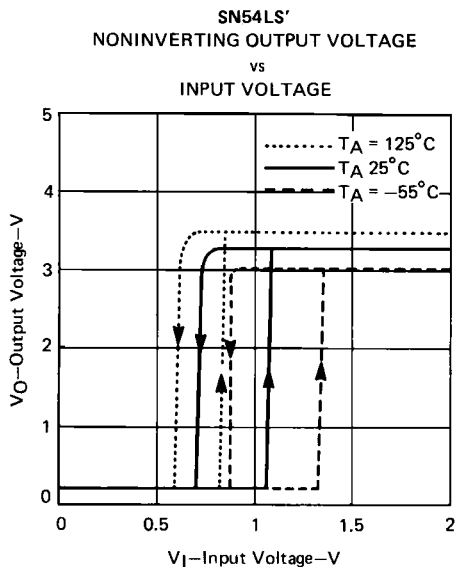

**FIGURE 3**

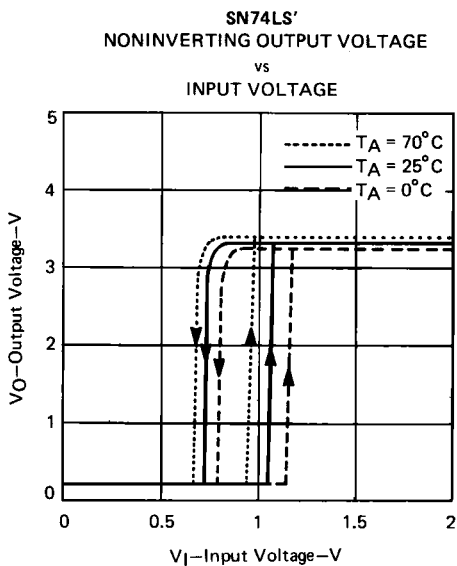

**FIGURE 4**

# TYPES SN54LS641, SN54LS642, SN54LS644, SN74LS641, SN74LS642, SN74LS644 OCTAL BUS TRANSCEIVERS WITH OPEN-COLLECTOR OUTPUTS

## absolute maximum ratings over operating free-air temperature range (unless otherwise noted)

Supply voltage, $V_{CC}$ (see Note 1)	7 V
Input voltage: All inputs and I/O ports	7 V
Operating free-air temperature range: SN54LS641, SN54LS642, SN54LS644	– 55° C to 125° C
SN74LS641, SN74LS642, SN74LS644	0° C to 70° C
Storage temperature range	– 65° C to 150° C

NOTE 1: Voltage values are with respect to network ground terminal.

## recommended operating conditions

PARAMETER	SN54LS641 SN54LS642 SN54LS644			SN74LS641 SN74LS642 SN74LS644			UNIT
	MIN	NOM	MAX	MIN	NOM	MAX	
$V_{CC}$ Supply voltage	4.5	5	5.5	4.75	5	5.25	V
$V_{IH}$ High-level input voltage	2			2			V
$V_{IL}$ Low-level input voltage			0.5			0.6	V
$V_{OH}$ High-level output voltage			5.5			5.5	V
$I_{OL}$ Low-level output current			12			24 48 <sup>§</sup>	mA
$T_A$ Operating free-air temperature	– 55		125	0		70	°C

§ The 48 mA limit applies for the SN74LS641-1, SN74LS642-1, and SN74LS644-1 only.

## electrical characteristics over recommended operating free-air temperature range (unless otherwise noted)

PARAMETER	TEST CONDITIONS †	SN54LS641 SN54LS642 SN54LS644			SN74LS641 SN74LS642 SN74LS644			UNIT	
		MIN	TYP ‡	MAX	MIN	TYP ‡	MAX		
$V_{IK}$	$V_{CC} = \text{MIN}, I_I = -18 \text{ mA}$			– 1.5			– 1.5	V	
Hysteresis ( $V_{T+} - V_{T-}$ )	$V_{CC} = \text{MIN}, A \text{ or } B \text{ input}$	0.1	0.4		0.2	0.4		V	
$I_{OH}$	$V_{CC} = \text{MIN}, V_{IH} = 2 \text{ V}, V_{IL} = \text{MAX}, V_{OH} = 5.5 \text{ V}$			0.1			0.1	mA	
$V_{OL}$	$V_{CC} = \text{MIN}, V_{IH} = 2 \text{ V}, V_{IL} = \text{MAX}$	$I_{OL} = 12 \text{ mA}$	0.25	0.4	0.25	0.4		V	
		$I_{OL} = 24 \text{ mA}$			0.35	0.5			
		$I_{OL} = 48 \text{ mA}^{\S}$			0.4	0.5			
$I_I$	A or B	$V_{CC} = \text{MAX}$	$V_I = 5.5 \text{ V}$		0.1		0.1	mA	
	DIR or $\bar{G}$		$V_I = 7 \text{ V}$		0.1		0.1		
$I_{IH}$	$V_{CC} = \text{MAX}, V_I = 2.7 \text{ V}$			20			20	$\mu\text{A}$	
$I_{IL}$	$V_{CC} = \text{MAX}, V_I = 0.4 \text{ V}$			– 0.4			– 0.4	mA	
$I_{CC}$	Outputs high	$V_{CC} = \text{MAX},$ Outputs open		48	70		48	70	mA
	Outputs low			62	90		62	90	
	Outputs at Hi-Z			64	95		64	95	

† For conditions shown as MIN or MAX, use the appropriate value specified under recommended operating conditions.

‡ All typical values are at  $V_{CC} = 5 \text{ V}, T_A = 25^\circ \text{C}$ .

§ The 48 mA condition applies for the SN74LS641-1, SN74LS642-1, and SN74LS644-1 only.

3

TTL DEVICES

**TYPES SN54LS641, SN54LS642, SN54LS644  
SN74LS641, SN74LS642, SN74LS644  
OCTAL BUS TRANSCEIVERS WITH OPEN-COLLECTOR OUTPUTS**

switching characteristics at  $V_{CC} = 5\text{ V}$ ,  $T_A = 25^\circ\text{C}$

PARAMETER	FROM (INPUT)		TO (OUTPUT)		TEST CONDITIONS	'LS641, 'LS641-1		'LS642, 'LS642-1		'LS644, 'LS644-1		UNIT
	A	B	A	B		MIN	TYP	MAX	MIN	TYP	MAX	
$t_{PLH}$ Propagation delay time, low-to-high-level output	B	A	A	B	$C_L = 45\text{ pF}$ , $R_L = 667\ \Omega$ , See Note 2	17	25	19	25	17	25	ns
$t_{PHL}$ Propagation delay time, high-to-low-level output	A	B	B	A		16	25	14	25	14	25	ns
$t_{PLH}$ Output disable time from low level	$\bar{G}$ , DIR	A	$\bar{G}$ , DIR	A		23	40	26	40	26	40	ns
$t_{PHL}$ Output enable time from high level	$\bar{G}$ , DIR	A	$\bar{G}$ , DIR	A		25	40	28	40	25	40	ns
	$\bar{G}$ , DIR	B	$\bar{G}$ , DIR	B		34	50	43	60	43	60	ns

NOTE 2: See General Information Section for load circuits and voltage waveforms.

schematics of inputs and outputs

