

DESCRIPTION

The SD1429 is a 12.5 V Class C epitaxial silicon NPN planar transistor designed primarily for UHF communications. This device utilizes “Tuned Q” technology which consists of an input matching network on the base to achieve optimum gain and broadband characteristics.

IMPORTANT: For the most current data, visit: <http://www.advancedpower.com>

KEY FEATURES

- 470 MHz
- 12.5 Volts
- Common Emitter
- $P_{OUT} = 12$ W Min.
- $G_P = 7.8$ dB Gain

APPLICATIONS/BENEFITS

- UHF Mobile Applications

ABSOLUTE MAXIMUM RATINGS ($T_{CASE} = 25^{\circ}C$)

Symbol	Parameter	Value	Unit
V_{CBO}	Collector-Base Voltage	36	V
V_{CEO}	Collector-Emitter Voltage	16	V
V_{CES}	Collector-Emitter Voltage	36	V
V_{EBO}	Emitter-Base Voltage	4.0	V
I_C	Device Current	3.4	A
P_{DISS}	Power Dissipation	37.5	W
T_J	Junction Temperature	+200	$^{\circ}C$
T_{STG}	Storage Temperature	-65 to +150	$^{\circ}C$

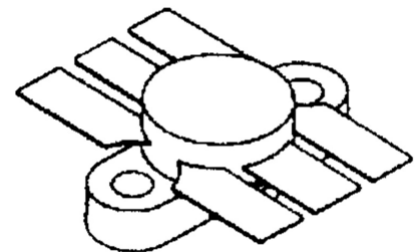

**.500 6LFL (M111)
EPOXY SEALED**

THERMAL DATA

$R_{TH(j-c)}$	Junction-Case Thermal Resistance	4.6	$^{\circ}C/W$
---------------	----------------------------------	-----	---------------

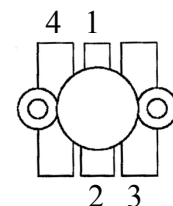
PIN CONNECTION

1. Collector 3. Base
2. Emitter 4. Emitter

STATIC ELECTRICAL SPECIFICATIONS (T_{CASE} = 25°C)

Symbol	Test Conditions	SD1429			Units
		Min.	Typ.	Max.	
BV_{CES}	I_C = 200 mA V_{BE} = 0 V	36	—	—	V
BV_{CEO}	I_C = 200 mA I_B = 0 mA	16	—	—	V
BV_{EBO}	I_E = 4 mA I_C = 0 mA	4.0	—	—	V
I_{CBO}	V_{CB} = 15 V I_E = 0 mA	—	—	2.0	mA
h_{FE}	V_{CE} = 5 V I_C = 500 mA	20	—	200	—

DYNAMIC ELECTRICAL SPECIFICATIONS (T_{CASE} = 25°C)

Symbol	Test Conditions	SD1429			Units
		Min.	Typ.	Max.	
P_{OUT}	f = 470 MHz P_{IN} = 2 W V_{CE} = 12.5 V	12	—	—	W
G_P	f = 470 MHz P_{IN} = 2 W V_{CE} = 12.5 V	7.8	—	—	dB
C_{OB}	f = 1 MHz V_{CB} = 12 V	—	—	50	pF

PACKAGE STYLE M111

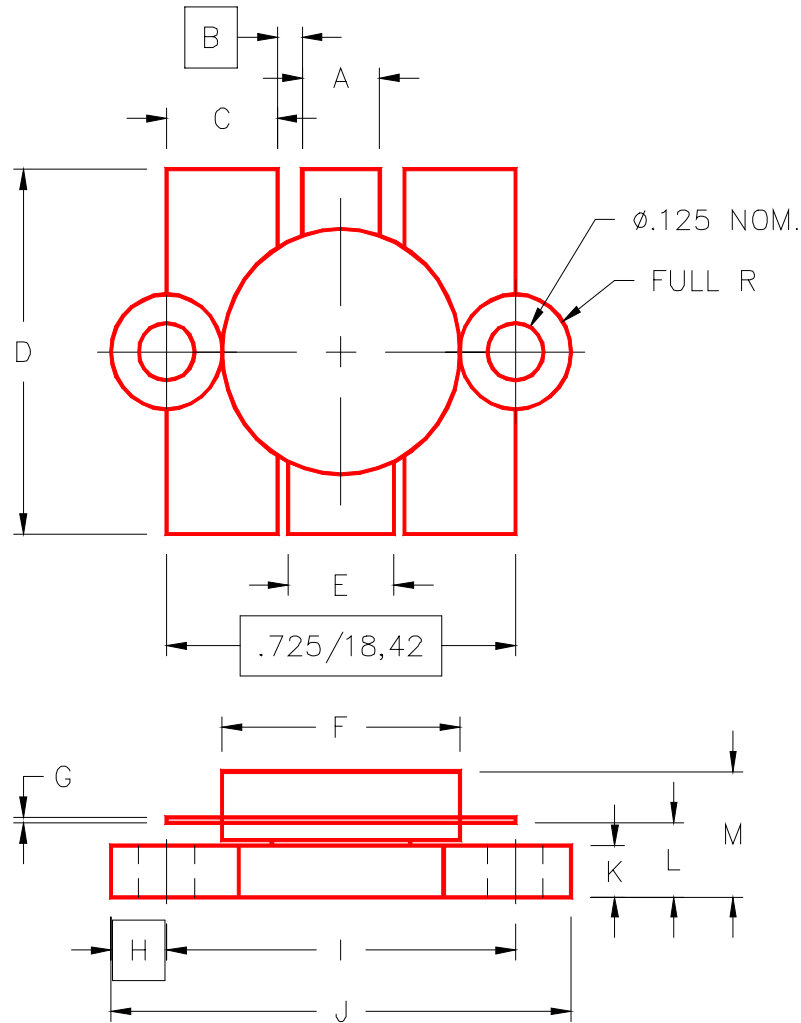

	MINIMUM INCHES/MM	MAXIMUM INCHES/MM		MINIMUM INCHES/MM	MAXIMUM INCHES/MM
A	.150/3,43	.160/4,06	I	.720/18,29	.730/18,54
B	.045/1,14		J	.970/24,64	.980/24,89
C	.210/5,33	.220/5,59	K	.095/2,41	.105/2,67
D	.835/21,21	.865/21,97	L	.150/3,81	.170/4,32
E	.200/5,08	.210/5,33	M		.280/7,11
F	.490/12,45	.510/12,95			
G	.003/0,08	.007/0,18			
H	.125/3,18				

