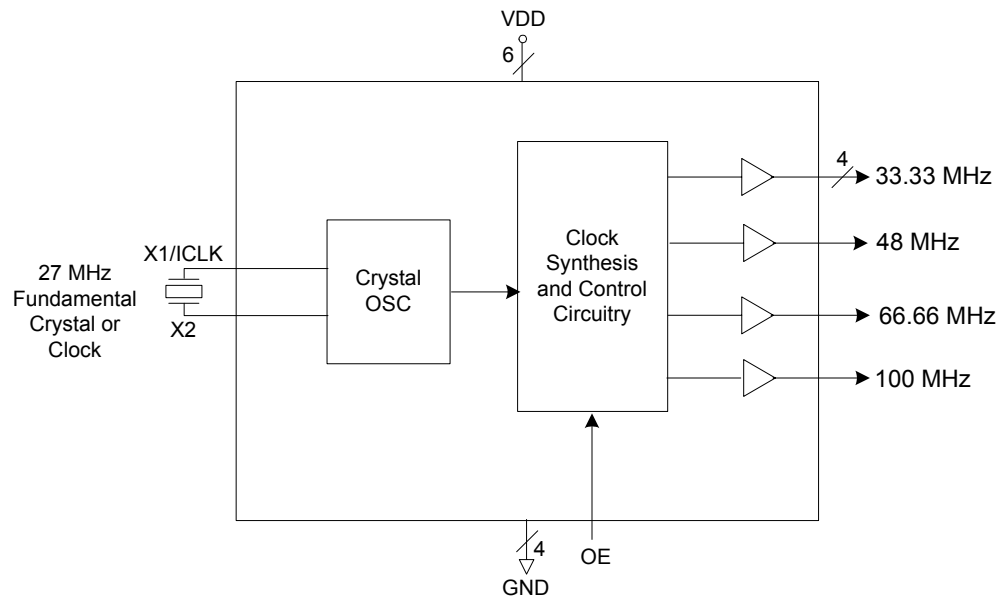

**PRV AND STB CLOCK SOURCE**
**ICS650-22**
**Description**

The ICS650-22 is a low-cost, low-jitter, high-performance clock synthesizer for personal video recorders (PVR) and set-top box (STB) applications. Using analog Phase-Locked Loop (PLL) techniques, the device accepts a 27 MHz crystal input to produce multiple clocks for personal video recorder applications.

**Features**

- Packaged in 20-pin narrow SSOP (QSOP)
- Available in Pb (lead) free package
- 27 MHz fundamental crystal or clock input
- Zero ppm synthesis error in all clocks
- Low skew 33.33 MHz clock outputs
- Output enable controls all outputs
- Full CMOS output swing with 25 mA output drive capability at TTL levels
- Advanced, low-power, sub-micron CMOS process
- 3.3 V  $\pm 10\%$  operating voltage

**Block Diagram**

## Pin Assignment

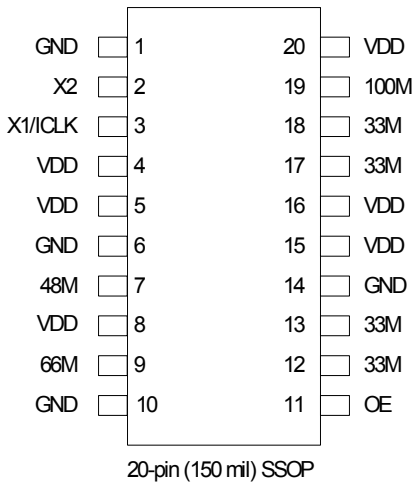

## Pin Descriptions

Pin Number	Pin Name	Pin Type	Pin Description
1	GND	Power	Connect to ground.
2	X2	Input	Connect to a crystal input or leave open for ICLK.
3	X1/ICLK	Input	Connect to a crystal or reference clock input.
4, 5	VDD	Power	Connect to +3.3 V.
6	GND	Power	Connect to ground.
7	48M	Output	48 MHz clock output.
8	VDD	Power	Connect to +3.3 V.
9	66M	Output	66 MHz clock output.
10	GND	Power	Connect to ground.
11	OE	Input	Output enable active high. Internal pull-up resistor.
12, 13	33M	Output	33.33 MHz clock output.
14	GND	Power	Connect to ground.
15, 16	VDD	Power	Connect to +3.3 V.
17, 18	33M	Output	33.33 MHz clock output.
19	100M	Output	100 MHz clock output.
20	VDD	Power	Connect to +3.3 V.

## Absolute Maximum Ratings

Stresses above the ratings listed below can cause permanent damage to the ICS650-22. These ratings, which are standard values for ICS commercially rated parts, are stress ratings only. Functional operation of the device at these or any other conditions above those indicated in the operational sections of the specifications is not implied. Exposure to absolute maximum rating conditions for extended periods can affect product reliability. Electrical parameters are guaranteed only over the recommended operating temperature range.

Item	Rating
Supply Voltage, VDD	7 V
All Inputs and Outputs	-0.5 V to VDD+0.5 V
Ambient Operating Temperature	-40 to +85°C
Storage Temperature	-65 to +150°C
Junction Temperature	125°C
Soldering Temperature	260°C

## Recommended Operation Conditions

Parameter	Min.	Typ.	Max.	Units
Ambient Operating Temperature	0	-	+70	°C
Power Supply Voltage (measured in respect to GND)	+3.0	+3.3	+3.6	V

## DC Electrical Characteristics

Unless stated otherwise, VDD = 3.3V ±10%, Ambient Temperature 0 to +70°C

Parameter	Symbol	Conditions	Min.	Typ.	Max.	Units
Operating Voltage	VDD		3.0	3.3	3.6	V
Input High Voltage	V <sub>IH</sub>		VDD/2+1	VDD/2		V
Input Low Voltage	V <sub>IL</sub>			VDD/2	VDD/2-1	V
Output High Voltage	V <sub>OH</sub>	I <sub>OH</sub> = -25 mA	2.4			V
Output Low Voltage	V <sub>OL</sub>	I <sub>OL</sub> = +25 mA			0.5	V
Output High Voltage	V <sub>OL</sub>	I <sub>OH</sub> = -8 mA	VDD-0.4			V
Operating Supply Current	I <sub>DD</sub>	No Load, OE=1		29		mA
		No Load, OE=0		13		mA
Short Circuit Current	I <sub>OS</sub>	Each output		±70		mA
Internal Pull-up Resistor	R <sub>PU</sub>	Input select		390		kΩ

## AC Electrical Characteristics

Unless stated otherwise, VDD = 3.3V ±10%, Ambient Temperature 0 to +70° C

Parameter	Symbol	Conditions	Min.	Typ.	Max.	Units
Input Frequency				27		MHz
Output Rise Time	t <sub>OR</sub>	0.8 to 2.0 V (note 1)		500		ps
Output Fall Time	t <sub>OF</sub>	2.0 to 0.8 V (note 1)		500		ps
Output Clock Duty Cycle		At VDD/2 (note 1)	45	50	55	%
Frequency Error		All clocks			0	ppm
Absolute Jitter, short term		33M, 100M clocks (note 1)		±100		ps
Absolute Jitter, short term		48M clock (note 1)		±160		ps
Absolute Jitter, short term		66M clock (note 1)		±140		ps
Output-to-output Skew, 33M only		Rising edge at VDD/2 (note 1)		0	150	ps

Note 1: Measured with a 15 pF load.

## Thermal Characteristics

Parameter	Symbol	Conditions	Min.	Typ.	Max.	Units
Thermal Resistance Junction to Ambient	θ <sub>JA</sub>	Still air		135		°C/W
	θ <sub>JA</sub>	1 m/s air flow		93		°C/W
	θ <sub>JA</sub>	3 m/s air flow		78		°C/W
Thermal Resistance Junction to Case	θ <sub>JC</sub>			60		°C/W

## Package Outline and Package Dimensions (20-pin SSOP, 150 Mil. Body)

Package dimensions are kept current with JEDEC Publication No. 95

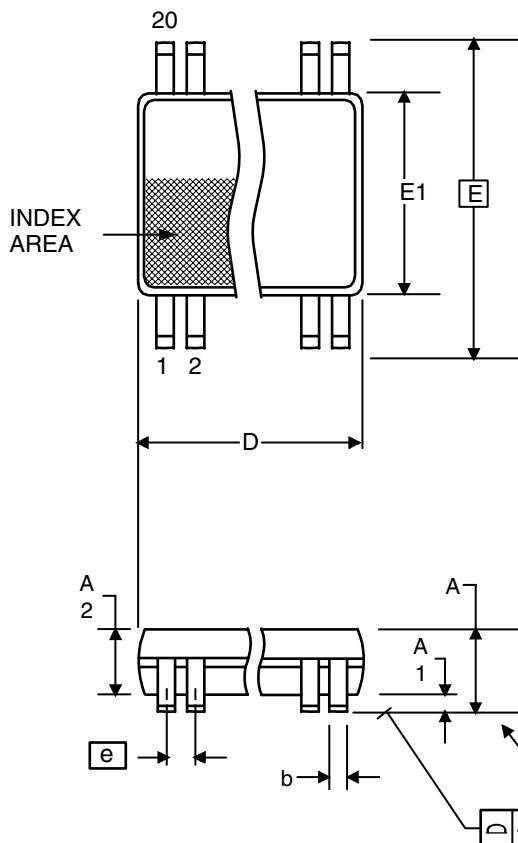

Symbol	Millimeters		Inches	
	Min	Max	Min	Max
A	1.35	1.75	.053	.069
A1	0.10	0.25	.0040	.010
A2	--	1.50	--	.059
b	0.20	0.30	0.008	0.012
C	0.18	0.25	.007	.010
D	8.55	8.75	.337	.344
E	5.80	6.20	.228	.244
E1	3.80	4.00	.150	.157
e	0.635 Basic		0.025 Basic	
L	0.40	1.27	.016	.050
$\alpha$	0°	8°	0°	8°

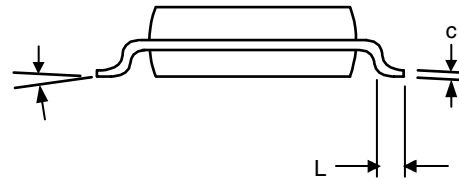

## Ordering Information

Part / Order Number	Marking	Shipping Packaging	Package	Temperature
ICS650R-22	650R-22	Tubes	20-pin SSOP	0 to +70°C
ICS650R-22T	650R-22	Tape and Reel	20-pin SSOP	0 to +70°C
ICS650R-22LFT	650R-22L	Tubes	20-pin SSOP	0 to +70°C
ICS650R-22LFT	650R-22L	Tape and Reel	20-pin SSOP	0 to +70°C

"LF" denotes Pb (lead) free package.

While the information presented herein has been checked for both accuracy and reliability, Integrated Circuit Systems (ICS) assumes no responsibility for either its use or for the infringement of any patents or other rights of third parties, which would result from its use. No other circuits, patents, or licenses are implied. This product is intended for use in normal commercial applications. Any other applications such as those requiring extended temperature range, high reliability, or other extraordinary environmental requirements are not recommended without additional processing by ICS. ICS reserves the right to change any circuitry or specifications without notice. ICS does not authorize or warrant any ICS product for use in life support devices or critical medical instruments.

Innovate with IDT and accelerate your future networks. Contact:

**www.IDT.com**

**For Sales**

800-345-7015  
408-284-8200  
Fax: 408-284-2775

**For Tech Support**

<product line email>  
<product line phone>

---

**Corporate Headquarters**

Integrated Device Technology, Inc.  
6024 Silver Creek Valley Road  
San Jose, CA 95138  
United States  
800 345 7015  
+408 284 8200 (outside U.S.)

**Asia Pacific and Japan**

Integrated Device Technology  
Singapore (1997) Pte. Ltd.  
Reg. No. 199707558G  
435 Orchard Road  
#20-03 Wisma Atria  
Singapore 238877  
+65 6 887 5505

**Europe**

IDT Europe, Limited  
Prime House  
Barnett Wood Lane  
Leatherhead, Surrey  
United Kingdom KT22 7DE  
+44 1372 363 339



www.IDT.com