

SN74F125 QUADRUPLE BUS BUFFER GATE WITH 3-STATE OUTPUTS

SDFS016A - D3211, JANUARY 1989 - REVISED OCTOBER 1993

- 3-State Outputs Drive Bus Lines or Buffer Memory Address Registers
- Package Options Include Plastic Small-Outline Packages and Standard Plastic 300-mil DIPs

D OR N PACKAGE
(TOP VIEW)

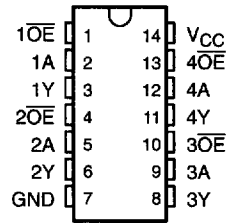

description

The SN74F125 features independent line drivers with 3-state outputs. Each output is disabled when the associated output enable (OE) input is high.

The SN74F125 is characterized for operation from 0°C to 70°C.

FUNCTION TABLE
(each buffer)

INPUTS		OUTPUT
OE	A	Y
L	H	H
L	L	L
H	X	Z

logic symbol†

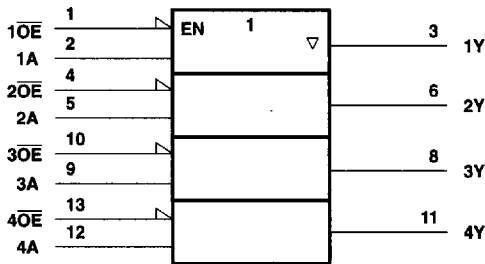

† This symbol is in accordance with ANSI/IEEE Std 91-1984 and IEC Publication 617-12.

logic diagram (positive logic)

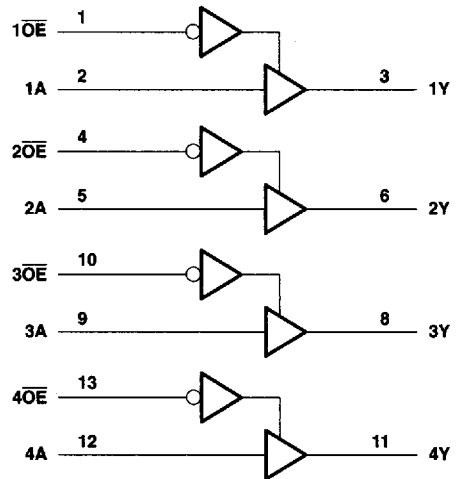

SN74F125

QUADRUPLE BUS BUFFER GATE

WITH 3-STATE OUTPUTS

SDFS016A - D3211, JANUARY 1989 - REVISED OCTOBER 1993

absolute maximum ratings over operating free-air temperature range (unless otherwise noted)†

Supply voltage range, V_{CC}	-0.5 V to 7 V
Input voltage range, V_I (see Note 1)	-1.2 V to 7 V
Input current range	-30 mA to 5 mA
Voltage range applied to any output in the disabled or power-off state	-0.5 V to 5.5 V
Voltage range applied to any output in the high state	-0.5 V to V_{CC}
Current into any output in the low state	128 mA
Operating free-air temperature range	0°C to 70°C
Storage temperature range	-65°C to 150°C

† Stresses beyond those listed under "absolute maximum ratings" may cause permanent damage to the device. These are stress ratings only and functional operation of the device at these or any other conditions beyond those indicated under "recommended operating conditions" is not implied. Exposure to absolute-maximum-rated conditions for extended periods may affect device reliability.

NOTE 1: The input voltage ratings may be exceeded provided the input current ratings are observed.

recommended operating conditions

	MIN	NOM	MAX	UNIT
V_{CC} Supply voltage	4.5	5	5.5	V
V_{IH} High-level input voltage	2			V
V_{IL} Low-level input voltage			0.8	V
I_{IK} Input clamp current			-18	mA
I_{OH} High-level output current			-15	mA
I_{OL} Low-level output current			64	mA
T_A Operating free-air temperature	0		70	°C

electrical characteristics over recommended operating free-air temperature range (unless otherwise noted)

PARAMETER	TEST CONDITIONS	MIN	TYP‡	MAX	UNIT
V_{IK}	$V_{CC} = 4.5$ V, $I_I = -18$ mA			-1.2	V
V_{OH}	$V_{CC} = 4.5$ V	$I_{OH} = -3$ mA	2.4	3.3	V
		$I_{OH} = -15$ mA	2	3.1	
	$V_{CC} = 4.75$ V, $I_{OH} = -3$ mA	2.7			
V_{OL}	$V_{CC} = 4.5$ V, $I_{OL} = 64$ mA		0.4	0.55	V
I_I	$V_{CC} = 0$, $V_I = 7$ V			0.1	mA
I_{IH}	$V_{CC} = 5.5$ V, $V_I = 2.7$ V			20	μA
I_{IL}	$V_{CC} = 5.5$ V, $V_I = 0.5$ V			-20	μA
I_{OZH}	$V_{CC} = 5.5$ V, $V_O = 2.7$ V			50	μA
I_{OZL}	$V_{CC} = 5.5$ V, $V_O = 0.5$ V			-50	μA
$I_{OS}§$	$V_{CC} = 5.5$ V, $V_O = 0$	-100		-225	mA
I_{CCH}	$V_{CC} = 5.5$ V, Outputs open		17	24	mA
I_{CCL}	$V_{CC} = 5.5$ V, Outputs open		28	40	mA
I_{CCZ}	$V_{CC} = 5.5$ V, Outputs open		25	35	mA

‡ All typical values are at $V_{CC} = 5$ V, $T_A = 25$ °C.

§ Not more than one output should be shorted at a time, and the duration of the short circuit should not exceed one second.

SN74F125
QUADRUPLE BUS BUFFER GATE
WITH 3-STATE OUTPUTS

SDFS016A - D3211, JANUARY 1989 - REVISED OCTOBER 1993

switching characteristics (see Note 2)

PARAMETER	FROM (INPUT)	TO (OUTPUT)	V _{CC} = 5 V, C _L = 50 pF, R _L = 500 Ω, T _A = 25°C			V _{CC} = 4.5 V to 5.5 V, C _L = 50 pF, R _L = 500 Ω, T _A = MIN to MAX†		UNIT
			MIN	TYP	MAX	MIN	MAX	
t _{PLH}	A	Y	1.2	3.6	6	1.2	6.5	ns
t _{PHL}			2.2	5.1	7.5	2.2	8	
t _{PZH}	OE	Y	2.7	5.1	7.5	2.7	8.5	ns
t _{PZL}			3.2	5.6	8	3.2	9	
t _{PHZ}	OE	Y	1	3.1	5	1	6	ns
t _{PLZ}			1	3.1	5.5	1	6	

† For conditions shown as MIN or MAX, use the appropriate value specified under recommended operating conditions.

NOTE 2: Load circuits and waveforms are shown in Section 1.

