



SCHOTTKY DIODE MODULE TYPES 300A

Features

High Surge Capability
Types Up to 100V V_{RRM}

300Amp Rectifier
20-100 Volts

TWIN TOWER

Maximum Ratings

Operating Temperature: -55°C to $+150^{\circ}\text{C}$
Storage Temperature: -55°C to $+150^{\circ}\text{C}$

Part Number	Maximum Recurrent Peak Reverse Voltage	Maximum RMS Voltage	Maximum DC Blocking Voltage
MBR30020CT(R)	20V	14V	20V
MBR30030CT(R)	30V	21V	30V
MBR30035CT(R)	35V	25V	35V
MBR30040CT(R)	40V	28V	40V
MBR30045CT(R)	45V	32V	45V
MBR30060CT(R)	60V	42V	60V
MBR30080CT(R)	80V	57V	80V
MBR300100CT(R)	100V	70V	100V

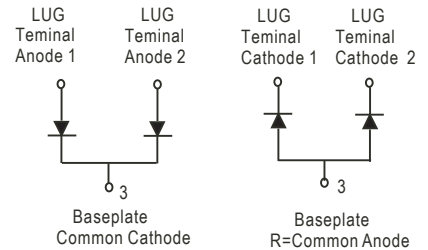
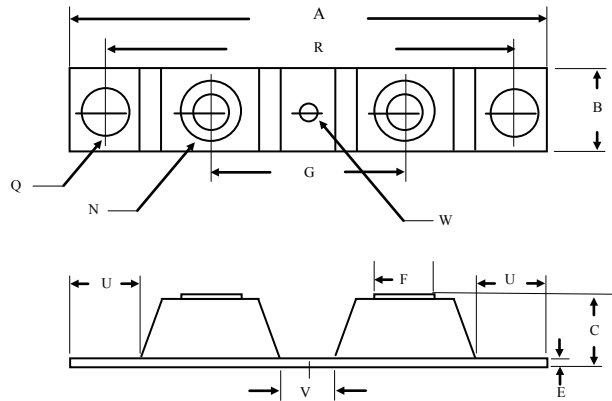

Electrical Characteristics @ 25°C Unless Otherwise Specified

Average Forward Current (Per pkg)	$I_{F(AV)}$	300A	$TC=125^{\circ}\text{C}$
Peak Forward Surge Current (Per leg)	I_{FSM}	2000A	8.3ms, half sine
Maximum Instantaneous Forward Voltage (Per leg) 20V~45V 50V~60V 80V~100V	V_F	0.70V 0.75V 0.84V	$I_{FM}=150\text{A}; T_J=25^{\circ}\text{C}$
Maximum Instantaneous Reverse Current At Rated DC Blocking Voltage (Per leg)	I_R	1mA 10 mA 50 mA	$T_J=25^{\circ}\text{C}$ $T_J=100^{\circ}\text{C}$ $T_J=150^{\circ}\text{C}$
Maximum Thermal Resistance Junction To Case (Per leg)	$R_{\theta jc}$	0.40°C/W	

DIM	Inches		Millimeters	
	Min	Max	Min	Max
A	-----	3.630	-----	92.40
B	0.700	0.800	17.78	20.32
C	-----	0.650	-----	16.51
E	0.130	0.141	3.30	3.60
F	0.482	0.490	12.25	12.45
G	1.368	BSC	34.75	BSC
N	1/4-20 UNC FULL			
Q	0.275	0.290	6.99	7.37
R	3.150	BSC	80.01	BSC
U	0.600	-----	15.24	-----
V	0.312	0.370	7.92	9.40
W	0.180	0.195	4.57	4.95

NOTE :

(1) Pulse Test: Pulse Width 300 μ sec. Duty Cycle < 2%



Figure .1- Typical Forward Characteristics

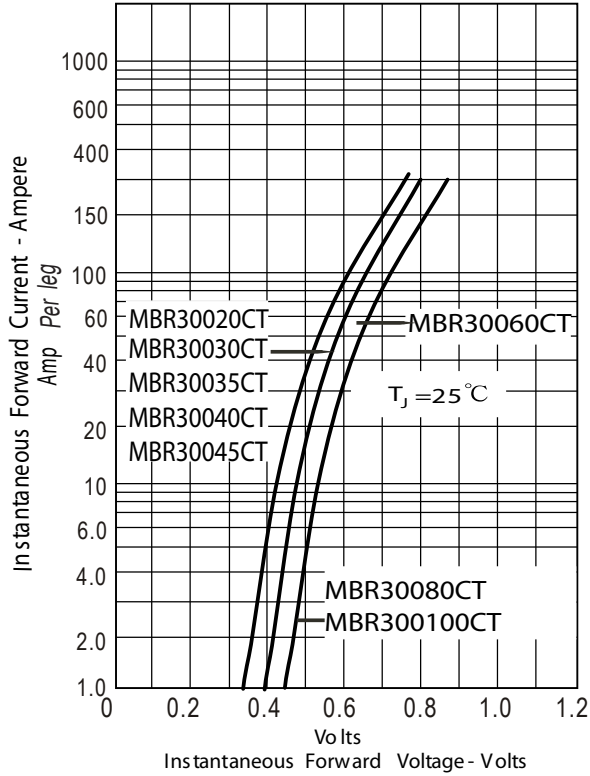

Figure .2- Forward Derating Curve

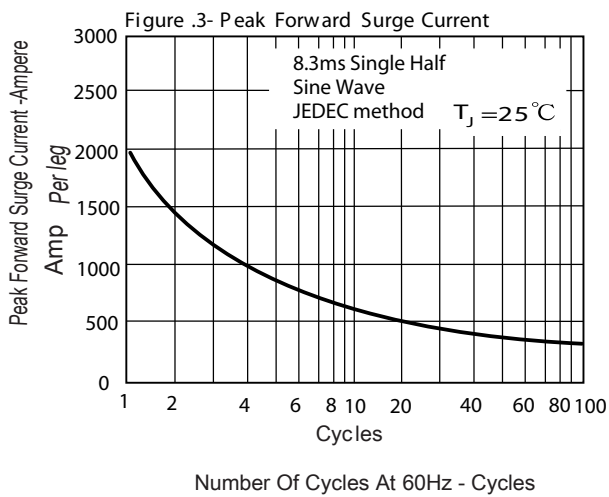
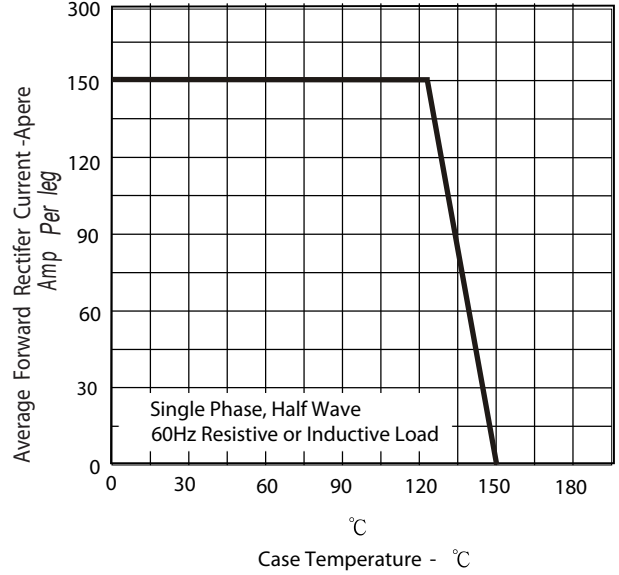

Figure .4- Typical Reverse Characteristics

